

Profipress

Submittal Package



Inhaltsverzeichnis

1	Produktgruppenbeschreibung	3
2	Anwendungsbereiche	5
3	Zulässige Rohre	8
4	Zertifikate	9
5	Z-Maße	14
6	Impressum	90

Produktgruppenbeschreibung

Strömungsoptimiertes Pressverbindersystem aus Kupfer (99,9 % Cu-DHP), Rotguss oder Siliziumbronze für Kupferrohre. Pressverbinder zum Schutz des Dichtelements mit zylindrischer Rohrführung ausgestattet. Pressverbinder ab d64,0 mit Edelstahlschneidring zur Sicherstellung der mechanischen Belastbarkeit der Verbindung. Die Presskraft liegt vor und hinter dem Dichtelementesitz an. Geeignet für Auf- und Unterputz-Installationen von Steigleitungen und Etagen-Installationen.

Kennzeichnung

Hersteller, Rohrdimension, Charge, Zulassungskennzeichnungen (DVGW), grüner Punkt auf Pressende, oranger Aufkleber abziehbar als Verpressindikator ab d64,0

Pressverbinder mit SC-Contur

Versiehtlich nicht verpresste Verbindungen fallen bei der Dichtheitsprüfung sofort auf.

Viega gewährleistet das Erkennen unverpresster Verbindungen in den folgenden Druckbereichen:

min. Wasserdruck: 0,1 MPa / 100 kPa / 1 bar / 14,5 PSI

max. Wasserdruck: 0,65 MPa / 650 kPa / 6,5 bar / 94,3 PSI

min. Luftdruck: 22 hPa / 2,2 kPa / 22 mbar / 0,3 PSI

max. Luftdruck: 0,3 MPa / 300 kPa / 3 bar / 43,5 PSI

Dichtelemente

EPDM (Ethylen-Propylen-Dien-Kautschuk), schwarz, vormontiert

Hinweis

Die Dichtwerkstoffe des Pressverbindersystems unterliegen einer thermischen Alterung, die von der Medientemperatur und der Betriebsdauer abhängig ist.

Je höher die Medientemperatur, desto schneller schreitet die thermische Alterung des Dichtwerkstoffs voran. Bei speziellen Betriebsbedingungen, z.B. bei industriellen Wärmerückgewinnungsanlagen ist ein Abgleich der Angaben des Apparateherstellers mit den Angaben über das Pressverbindersystem erforderlich.

Vor dem Einsatz des Pressverbindersystems außerhalb der beschriebenen Einsatzbereiche oder bei Zweifeln über die richtige Werkstoffauswahl wenden Sie sich bitte an Viega.

Dimensionen

d12–108,0, Größenverfügbarkeit entsprechend nationaler Regelwerke

Werkzeuge

Die Funktionssicherheit der Viega Pressverbindersysteme hängt in erster Linie vom einwandfreien Zustand der verwendeten Presswerkzeuge ab. Viega empfiehlt die Verwendung von Viega Presswerkzeugen für das Verpressen von Viega Pressverbindern. Viega Presswerkzeuge müssen durch autorisierte Servicepartner regelmäßig gewartet werden.

Einsatzbereiche

Trinkwasser

Heizung/Heizkörperanbindung

Regenwasser

Druckluft, Inertgase

Kühlwasserleitungen

Industrieanwendungen

Anlagenbau

Hinweis

Die Nutzung des Systems für andere als die beschriebenen Einsatzbereiche und Medien muss mit Viega abgestimmt werden! Detaillierte Informationen zu Anwendungen, Einschränkungen und nationalen Normen und Richtlinien finden Sie in den Produktinformationen, entweder gedruckt oder auf der Viega Website.

Hinweis – Normen und Zulassungen

Pressverbinder geprüft nach DVGW-Arbeitsblatt W 534 mit DVGW-Prüfzeichen.

Zulassung für d12–108,0 nach ÖVGW Zertifikat 1.144.

Pressverbinder geeignet für Kupferrohre nach DIN EN 1057 (R290, hart für Sprinkleranlage) und DVGW-Arbeitsblatt GW 392.

Bei Einsatz in Heizungsanlagen VDI-Richtlinie 2035 und DIN EN 12828 beachten.

Hinweis – Einsatzgrenzen Trinkwasser

Das Pressverbindersystem Profipress ist für die Erstellung von Trinkwasserinstallationen nach DIN 1988-200 und EN 806-2 unter Beachtung der Werkstoffauswahl nach DIN EN 12502-1 und entsprechend der Bewertungsgrundlage für metallene Werkstoffe im Kontakt mit Trinkwasser des Umweltbundesamtes (UBA) geeignet. Bei einem Einsatz für andere Einsatzbereiche und bei Zweifel über die richtige Werkstoffauswahl wenden Sie sich bitte an Viega.

Rohre und Verbinder aus Kupfer dürfen hinsichtlich einer möglichen Grenzwertüberschreitung von Kupferionen gemäß TrinkwV nur verwendet werden, wenn der pH-Wert $\geq 7,4$ beträgt oder bei Werten von $\text{pH} = 7,0\text{--}7,4$ die Gesamtmenge an organischem Kohlenstoff TOC 1,5 mg/l nicht überschreitet!

Betriebsbedingungen

Das Pressverbindersystem Profipress ist bei nachfolgenden Betriebsparametern einsetzbar:

Trinkwasserinstallationen nach DIN 1988-200 / DIN EN 806-2

Betriebstemperatur max. 80 °C / 176 °F

Temperatur max. 95°C über einen Zeitraum von 60 min.

Heizungsanlagen nach DIN EN 12828

Betriebstemperatur max. 105 °C / 221 °F

Das Pressverbindersystem Profipress ist für den Nenndruck PN 16 ausgelegt.

Werkstoffe Verbinder

Kupfer: 99,9 % Cu-DHP

Rotguss: CC499K

Siliziumbronze: CC246E / CuSi4Zn9MnP

Viptool Software-Lösungen

Software-Lösungen für Servicemanagement und Detailplanung der Viega Rohrleitungs-, Vorwand-, Spül- und Entwässerungstechnik.

Zur einfachen und schnellen Lösung konkreter Planungsaufgaben nutzen Sie die weiteren kostenlosen Web-Applikationen auf der Viega Website.

Druckgefälle-Rechner

Web-Applikation zur einfachen und schnellen Bestimmung der Rohrleitungsdimension für Trinkwasser-, Heizungs- und Gasleitungen mit zugehöriger Druckverlusttabelle über das Gesamtsystem.

Änderungen und Irrtümer vorbehalten!

Die aktuellen Z- und Einbaumaße sowie weitere technische Angaben sind der Viega Website zu entnehmen und vor dem Kauf, bei Planung, Bauausführung und Nutzung zu prüfen. Unsere Produkte werden kontinuierlich optimiert.

Anwendungsbereiche

Systemname: Profipress, **Dichtelement:** EPDM

Anwendungsbereiche	Eigenschaften	Werte
Trinkwasser pH-Wert $\geq 7,4$ pH-Wert 7,0–7,4 mit TOC max. 1,5 mg/l Anforderungen nach TrinkwV Temperatur max. 95°C über einen Zeitraum von 60 min.	max. Betriebsdruck	1,6 MPa / 16 bar / 232,1 psi
	max. Betriebstemperatur	95 °C / 203 °F
Kühlwasser (geschlossener Kreislauf)	max. Betriebsdruck	1,6 MPa / 16 bar / 232,1 psi
	min. Betriebstemperatur	-25 °C / -13 °F
	max. Betriebstemperatur	105 °C / 221 °F
Brunnenwasser Anforderungen nach TrinkwV	max. Betriebsdruck	1,6 MPa / 16 bar / 232,1 psi
	max. Betriebstemperatur	80 °C / 176 °F
Heizungsanlagen nach DIN EN 12 828	max. Betriebsdruck	1,6 MPa / 16 bar / 232,1 psi
	max. Betriebstemperatur	105 °C / 221 °F
Frostschutzmittel Antifrogen N / Clariant Antifrogen L / Clariant Antifrogen Sol (Solaranlagen) / Clariant Ethylenglykol (Ethan-1,2-diol) Propylenglykol (1,2-Propandiol) Tyfoxit / Tyforop-Chemie Tyfocor / Tyforop-Chemie	max. Betriebsdruck	1,6 MPa / 16 bar / 232,1 psi
	min. Betriebstemperatur	-25 °C / -13 °F
	max. Betriebstemperatur	105 °C / 221 °F
Druckluft Ölkonzentration $\leq 25 \text{ mg/m}^3$ d12–108,0	max. Betriebsdruck	1,6 MPa / 16 bar / 232,1 psi
	max. Betriebstemperatur	60 °C / 140 °F
Argon d12–54	max. Betriebsdruck	1,6 MPa / 16 bar / 232,1 psi
	max. Betriebstemperatur	60 °C / 140 °F
Argon d64,0–108,0	max. Betriebsdruck	1 MPa / 10 bar / 145 psi
	max. Betriebstemperatur	60 °C / 140 °F
Carbogen Kohlenstoffdioxid + Sauerstoff trocken d12–54	max. Betriebsdruck	1,6 MPa / 16 bar / 232,1 psi
	max. Betriebstemperatur	60 °C / 140 °F
Carbogen d64,0–108,0	max. Betriebsdruck	1 MPa / 10 bar / 145 psi
	max. Betriebstemperatur	60 °C / 140 °F
Sauerstoff öl- und fettfrei halten d12–54	max. Betriebsdruck	1 MPa / 10 bar / 145 psi
	max. Betriebstemperatur	60 °C / 140 °F

Systemname: Profipress, **Dichtelement:** EPDM

Anwendungsbereiche	Eigenschaften	Werte
Stickstoff nach dem Verdampfer d12-54	max. Betriebsdruck	1,6 MPa / 16 bar / 232,1 psi
	max. Betriebstemperatur	60 °C / 140 °F
Stickstoff d64,0-108,0	max. Betriebsdruck	1 MPa / 10 bar / 145 psi
	max. Betriebstemperatur	60 °C / 140 °F
Wasserstoff d12-108,0	max. Betriebsdruck	0,5 MPa / 5 bar / 72,5 psi
	max. Betriebstemperatur	60 °C / 140 °F
Kohlendioxid trocken d12-54	max. Betriebsdruck	1,6 MPa / 16 bar / 232,1 psi
	max. Betriebstemperatur	60 °C / 140 °F
Kohlendioxid d64,0-108,0	max. Betriebsdruck	1 MPa / 10 bar / 145 psi
	max. Betriebstemperatur	60 °C / 140 °F
Kohlenmonoxid Edelstahlbauteile nicht zulässig d12-54	max. Betriebsdruck	1,6 MPa / 16 bar / 232,1 psi
	max. Betriebstemperatur	60 °C / 140 °F
Kohlenmonoxid d64,0-108,0	max. Betriebsdruck	1 MPa / 10 bar / 145 psi
	max. Betriebstemperatur	60 °C / 140 °F
Großvakuum P (absolut) = 1hPa	max. Betriebstemperatur	70 °C / 158 °F
Formiergas (trocken/Schweißschutzgas) Argon + Kohlenstoffdioxid (Beispiel Corgon) d12-54	max. Betriebsdruck	1,6 MPa / 16 bar / 232,1 psi
	max. Betriebstemperatur	60 °C / 140 °F
Formiergas (trocken/Schweißschutzgas) d64,0-108,0	max. Betriebsdruck	1 MPa / 10 bar / 145 psi
	max. Betriebstemperatur	60 °C / 140 °F
Krypton d12-54	max. Betriebsdruck	1,6 MPa / 16 bar / 232,1 psi
	max. Betriebstemperatur	60 °C / 140 °F
Krypton d64,0-108,0	max. Betriebsdruck	1 MPa / 10 bar / 145 psi
	max. Betriebstemperatur	60 °C / 140 °F
Neon d12-54	max. Betriebsdruck	1,6 MPa / 16 bar / 232,1 psi
	max. Betriebstemperatur	60 °C / 140 °F
Neon d64,0-108,0	max. Betriebsdruck	1 MPa / 10 bar / 145 psi
	max. Betriebstemperatur	60 °C / 140 °F
Xenon d12-54	max. Betriebsdruck	1,6 MPa / 16 bar / 232,1 psi
	max. Betriebstemperatur	60 °C / 140 °F







Systemname: Profipress, **Dichtelement:** EPDM











Anwendungsbereiche	Eigenschaften	Werte
Xenon d64,0–108,0	max. Betriebsdruck	1 MPa / 10 bar / 145 psi
	max. Betriebstemperatur	60 °C / 140 °F
synthetische Luft d12–54	max. Betriebsdruck	1,6 MPa / 16 bar / 232,1 psi
	max. Betriebstemperatur	60 °C / 140 °F
synthetische Luft d64,0–108,0	max. Betriebsdruck	1 MPa / 10 bar / 145 psi
	max. Betriebstemperatur	60 °C / 140 °F
Ethanol	max. Betriebsdruck	1,6 MPa / 16 bar / 232,1 psi
	max. Betriebstemperatur	25 °C / 77 °F
Kondensat von Wasserdampf ohne Verunreinigungen	max. Betriebsdruck	1,6 MPa / 16 bar / 232,1 psi
	max. Betriebstemperatur	105 °C / 221 °F
Aceton flüssig	max. Betriebsdruck	0,5 MPa / 5 bar / 72,5 psi
	min. Betriebstemperatur	-10 °C / 14 °F
	max. Betriebstemperatur	40 °C / 104 °F







Zulässige Rohre









Norm	DN	Außen-Ø	Wandstärke
Kupfer DIN EN 1057	10	12	0,8 1,0
	12	15	1,0
	15	18	
	20	22	
	25	28	1,0 1,5
	32	35	1,2 1,5
	40	42	
	50	54	1,5 2,0
	60	64,0	2,0
	65	76,1	
	80	88,9	
	100	108,0	2,5







Zertifikate

Dubai	Dubai Central Laboratory Department Attestation of Conformity Sanpress pipe 1.4521 and 1.4401
	ÖVGW Zertifikat Sanpress / Profipress
	ÜA Kennzeichen Profipress, Lötfittinge, Gewindefittinge
	ÜA Kennzeichen Raxinox Rohre
	ÜA Kennzeichen Sanpress, Raxofix, Maxiplex, RG-Gewindefittinge, Lötfittinge
	SAI Watermark Certificate of Conformity - Level 1 Propress Water, Sanpress and Sanpress Inox
	BCCA Certificate ATG Profipress, Sanpress, Sanpress Inox
	CCS Certificate of Type Approval Sanpress Inox, Seapress, Profipress
SZU	SZU Certificate Profipress, Profipress S
AMTEC	AMTEC Certificate Profipress, Sanpress, Sanpress Inox, Prestabo, Megapress, Profipress G, Sanpress Inox G, Megapress G
DEKRA	examination certificate Piping system Sanpress/Sanpress XL

	<p>DVGW type examination certificate Profipress (d 12 - 108)</p>
	<p>DVGW type examination certificate Sanpress-pipe 1.4521 (d 12 - 108)</p>
	<p>DVGW type examination certificate Sanpress with pipe 1.4401 (d 12 - 108)</p>
	<p>DVGW type examination certificate Sanpress with pipe 1.4521 (d 12 - 108)</p>
	<p>DVGW type examination certificate Sanpress pipe 1.4401 (d 12 - 108)</p>
	<p>TÜV Association Certificate Profipress, Sanpress, Sanpress Inox, Prestabo (d 15 - 108), Temponox</p>
	<p>VdS certificate Profipress (d 22 - 54)</p>
	<p>ETA Certificate Profipress, Profipress XL, Sanpress, Sanpress XL</p>
	<p>ETA Certificate Sanpress with pipe 1.4401 and 1.4521, (d 12-108)</p>
	<p>Eurofins Certificate Profipress (d 12-54)</p>
	<p>CSTB Certificate Profipress, Sanpress</p>

	<p>CSTB QB Certificate Profipress, Sanpress</p>
	<p>CSTB QB Certificate Profipress, Sanpress</p>
<p>Eurofins</p>	<p>Eurofins Certificate of sanitary conformity Profipress</p>
<p>Eurofins</p>	<p>Eurofins Certificate of sanitary conformity Sanpress</p>
<p>BSI</p>	<p>BSI Kitemark Certificate (BS EN 1254-7) Profipress, Profipress G</p>
	<p>Lloyd's Register Type Approval Certificate Profipress, ProPress</p>
	<p>Lloyd's Register Type Approval Certificate Sanpress</p>
<p>EMI</p>	<p>EMI certificate Profipress, Sanpress, Easytop, Sanpress Inox, Pexfit Pro Fosta, Smartpress, gunmetal threaded fittings</p>
<p>EMI</p>	<p>EMI Certificate of Constancy of Performance Profipress</p>
	<p>IAPMO UPC-I Certificate of Listing Copper, Cooper Alloy Fittings</p>
	<p>IAPMO UMC-I Certificate of Listing Copper, Cooper Alloy Fittings</p>
	<p>IRS Type Approval Certificate Seapress, Sanpress, Sanpress Inox, Profipress</p>

	<p>ICIM Hygiene certificate Profipress, Profipress XL, Sanpress Inox, Sanpress Inox XL, Sanpress, Sanpress XL, Sanfix Fosta, Raxofix, Smartpress, gunmetal threaded fittings, soldered fittings</p>
	<p>RINA Type Approval Certificate Profipress and ProPress</p>
	<p>Class NK Type Approval Certificate Seapress, Seapress XL, Profipress and Sanpress Inox</p>
	<p>KIWA Product certificate Profipress, Sanpress fittings</p>
	<p>KIWA Product certificate Sanpress Inox pipe 1.4521 and 1.4401</p>
	<p>KIWA Product certificate PE-Xc Smartloop pipe</p>
<p>SINTEF</p>	<p>SINTEF Certificate Profipress, Profipress XL</p>
<p>SINTEF</p>	<p>SINTEF Certificate Sanpress with pipe 1.4401 and 1.4521 (d 12-108)</p>
<p>SINTEF</p>	<p>SINTEF Certificate Smartloop</p>
	<p>ITB National Technical Assessment Profipress, Profipress XL, Profipress S</p>
	<p>ITB National Technical Assessment Profipress, Sanpress</p>
	<p>ITB Certificate of Constancy of Performance Profipress, Sanpress</p>

 10	ITB National Technical Assessment Sanpress Inox, Sanpress Inox XL, Sanpress, Sanpress XL
EITS	EITS Technical Approval Profipress
EITS	EITS Technical Approval Sanpress, Sanpress Inox
	RM Type Approval Certificate Profipress & Profipress XL types
 0134/05	RISE Certificate Profipress, Profipress XL, Profipress chromed
 0134/05	RISE Certificate Sanpress och Sanpress XL fittings
 0134/05	RISE Certificate Smartloop
	SGBC Certificate Profipress
IZV	IZV Certificate Profipress, Profipress XL
UKRCERTIFICATION	LLC UKRCertification Certificate of conformity Profipress
UKRCERTIFICATION	LLC UKRCertification Certificate of conformity Sanpress, Sanpress Inox
	ABS Approval Certificate Viega Metric CTS fittings Profipress, Profipress XL and Viega Imperial CTS fittings ProPress

Z-Maße

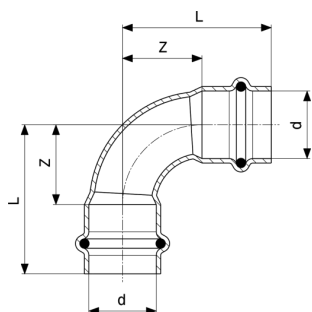

Profipress-Bogen 90°
- Kupfer
Modell 2416

Artikel	d	L	Z	L*	Z*
291 488	12	32	14		
291 501	15	38	16	40	18
291 495	18	40	18	44	22
291 518	22	49	26	42	19
291 525	28	55	31	58	34
291 532	35	59	33	68	42
291 549	42	69	33	86	50
291 556	54	95	55	105	65

L = Länge
Z = Z-Maß
L* = Vorgängerversion

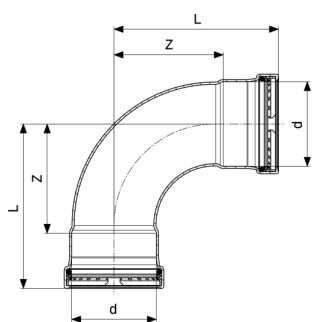

Profipress XL-Bogen 90°
- Kupfer
Modell 2416XL

Artikel	d	Z	L
577 681	64,0	84	127

Z = Z-Maß
L = Länge

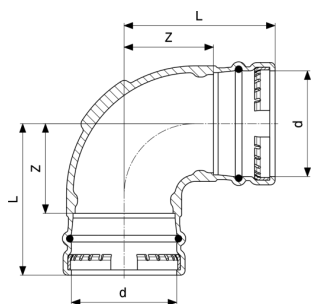

Sanpress XL-Bogen 90°
- Rotguss
Modell 2216XL

Artikel	d	Z	L	Z*	L*
350 697	76,1	44	97	68	114
350 680	88,9	67	120	49	102
350 703	108,0	77	140		

Z = Z-Maß
L = Länge
Z* = Vorgängerversion

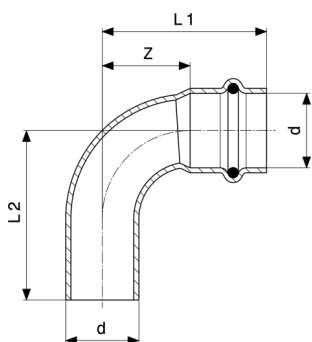

Profipress-Bogen 90°
- Kupfer
Modell 2416.1

Artikel	d	Z	L1	L2	Z*	L1*	L2*
291 648	12	14	32	34			
291 662	15	16	38	41	18	40	41
291 655	18	18	40	42	22	44	44
291 679	22	26	49	51	19	42	47
291 686	28	31	55	60	34	58	60
291 693	35	33	59	63	42	68	70
291 709	42	33	69	71	50	86	88
291 716	54	55	95	96	65	105	107

Z = Z-Maß
L = Länge
Z* = Vorgängerversion

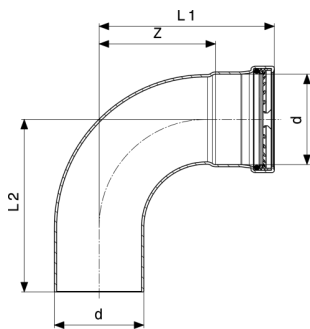

Profipress XL-Bogen 90°
- Kupfer
Modell 2416.1XL

Artikel	d	Z	L1	L2
577 698	64,0	84	127	126

Z = Z-Maß
L = Länge

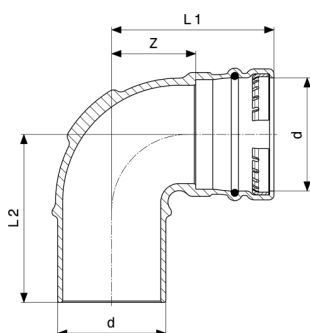

Sanpress XL-Bogen 90°
- Rotguss
Modell 2216.1XL

Artikel	d	Z	L1	L2	Z*	L1*	L2*
353 650	76,1	44	97	112	61	114	118
353 667	88,9	67	120	125			
353 674	108,0	76	140	145			

Z = Z-Maß
L = Länge
Z* = Vorgängerversion

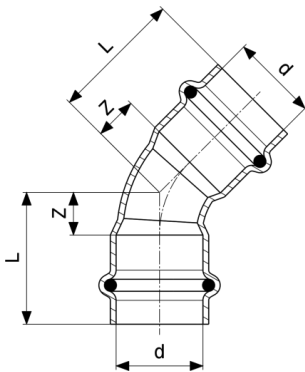

Profipress-Bogen 45°
- Kupfer
Modell 2426

Artikel	d	Z	L	Z*	L*
292 409	12	6	24		
292 348	15	7	29	8	30
292 416	18	7	29	9	31
292 355	22	11	34	9	32
292 362	28	12	36	14	38
292 379	35	15	41	17	43
292 386	42	17	53	21	57
292 393	54	22	62	27	67

Z = Z-Maß
L = Länge
Z* = Vorgängerversion

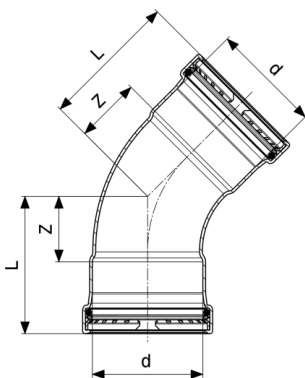

Profipress XL-Bogen 45°
- Kupfer
Modell 2426XL

Artikel	d	Z	L
577 766	64,0	39	82

Z = Z-Maß
L = Länge

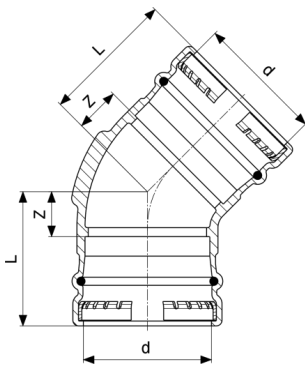

Sanpress XL-Bogen 45°
- Rotguss
Modell 2226XL

Artikel	d	Z	L
351 342	76,1	30	83
351 359	88,9	32	85
351 366	108,0	36	99

Z = Z-Maß
L = Länge

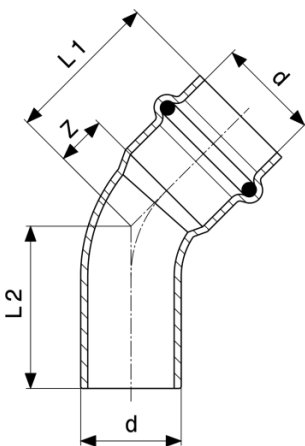

Profipress-Bogen 45°
- Kupfer
Modell 2426.1

Artikel	d	Z	L1	L2	Z*	L1*	L2*
292 577	12	6	24	26			
292 508	15	7	29	29	8	30	31
292 560	18	7	29	31	9	31	32
292 515	22	11	34	36	9	32	34
292 522	28	12	36	40	14	38	40
292 539	35	15	41	43	17	43	45
292 546	42	17	53	52	21	57	59
292 553	54	22	62	64	27	67	71

Z = Z-Maß
L = Länge
Z* = Vorgängerversion

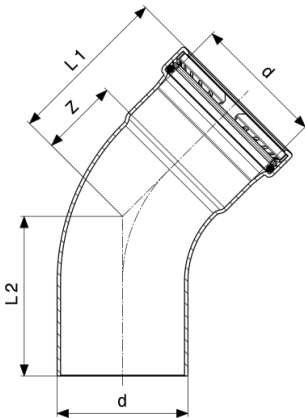

Profipress XL-Bogen 45°
- Kupfer
Modell 2426.1XL

Artikel	d	Z	L1	L2
577 773	64,0	39	82	82

Z = Z-Maß
L = Länge

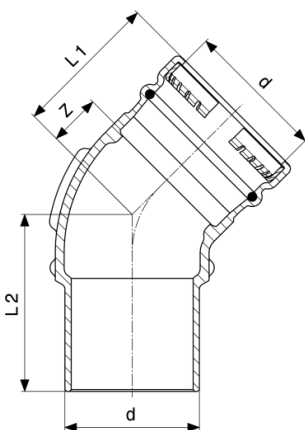

Sanpress XL-Bogen 45°
- Rotguss
Modell 2226.1XL

Artikel	d	Z	L1	L2
353 681	76,1	28	83	100
353 698	88,9	32	85	104
353 704	108,0	36	99	128

Z = Z-Maß
L = Länge

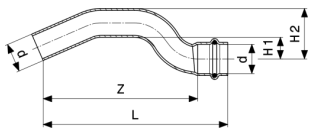

Profipress-Überbogen
- Kupfer
Modell 2427

Artikel	d	Z	L	H1	H2
322 359	12	82	100	12	24
322 342	15	98	120	13	28
322 335	18	98	120	13	31
322 328	22	118	141	17	39

Z = Z-Maß
L = Länge
H = Höhe

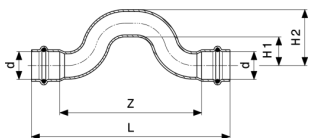

Profipress-Überbogen
- Kupfer
Modell 2428

Artikel	d	Z	L	H1	H2
352 134	15	90	134	20	35
352 141	18	100	144	20	38
352 158	22	115	161	23	45

Z = Z-Maß
L = Länge
H = Höhe

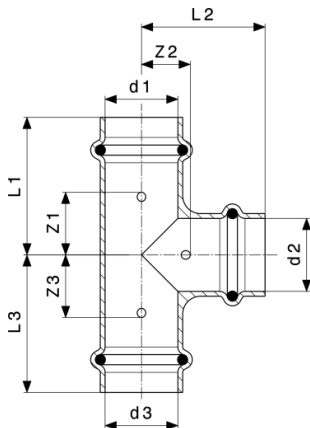

Profipress-T-Stück
- Kupfer
Modell 2418

Artikel	VdS	d1	d2	d3	Z1	Z2	Z3	L1	L2	L3
291 884		12	12	12	18	9	18	36	27	36
322 717		12	15	12	20	10	20	38	32	38
291 907		15	12	12	21	12	17	39	30	39
291 914		15	12	15	16	12	16	39	30	39
315 085		15	15	12	18	11	23	41	33	41
291 952		15	15	15	19	11	19	41	33	41
322 724		15	18	15	20	13	20	42	35	42
322 700		15	22	15	23	15	23	45	38	45
365 073		18	12	15	17	13	21	39	31	43
324 827		18	12	18	17	13	17	39	31	39
291 921		18	15	15	18	13	23	41	35	45
291 938		18	15	18	18	13	18	41	35	41
315 009		18	18	15	20	13	25	42	35	47
291 891		18	18	18	20	13	20	42	35	42
322 694		18	22	18	23	13	23	45	36	45
324 834		22	12	22	16	15	16	39	33	39
292 010		22	15	15	17	15	25	41	37	47
315 078		22	15	18	17	15	22	41	37	44
292 027		22	15	22	18	15	18	41	37	41
315 061		22	18	15	19	15	28	42	37	50
315 054		22	18	18	19	15	25	42	37	47
291 945		22	18	22	19	15	19	42	37	42
315 047		22	22	15	21	15	29	45	38	51
315 030		22	22	18	21	15	29	45	38	51

VdS = VdS-Zulassung

Z = Z-Maß

L = Länge

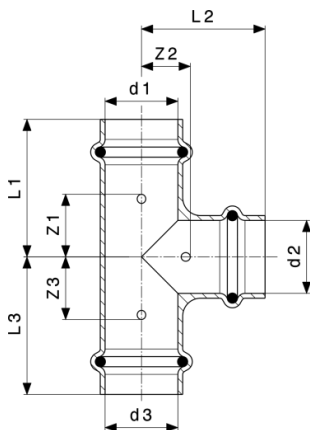

Profipress-T-Stück
- Kupfer
Modell 2418

Artikel	VdS	d1	d2	d3	Z1	Z2	Z3	L1	L2	L3
291 969	✓	22	22	22	19	15	19	42	38	42
322 687	✓	22	28	22	25	15	25	48	39	48
324 841		28	15	22	17	19	23	41	41	46
295 189		28	15	28	17	19	17	41	41	41
324 858		28	18	22	18	19	24	42	41	47
315 023		28	18	28	18	19	18	42	41	42
307 899	✓	28	22	22	21	19	27	45	42	50
295 196	✓	28	22	28	20	19	20	45	42	45
315 016	✓	28	28	22	23	19	30	48	43	53
291 976	✓	28	28	28	24	19	24	48	43	48
324 865		35	15	35	17	22	17	44	44	44
324 872		35	18	35	18	22	18	44	44	44
324 889	✓	35	22	28	19	22	29	46	45	53
292 034	✓	35	22	35	19	22	19	46	45	46
324 896	✓	35	28	28	22	22	32	49	46	56
292 041	✓	35	28	35	22	22	22	49	46	49
365 882	✓	35	35	22	26	22	40	52	48	63
365 080	✓	35	35	28	26	22	35	52	48	59
291 983	✓	35	35	35	26	22	26	52	48	52
324 902	✓	42	22	42	17	29	17	53	52	53
292 058	✓	42	28	42	19	29	19	55	53	55
292 065	✓	42	35	42	22	29	22	58	55	58
291 990	✓	42	42	42	29	29	29	65	65	65
324 919	✓	54	22	54	19	35	19	60	58	60

VdS = VdS-Zulassung

Z = Z-Maß

L = Länge

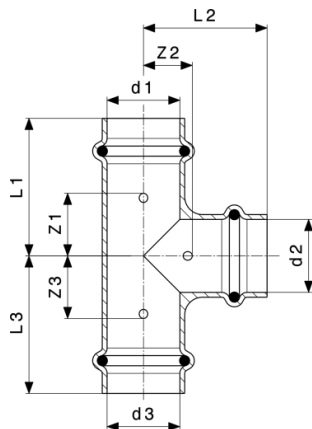

Profipress-T-Stück
- Kupfer
Modell 2418

Artikel	VdS	d1	d2	d3	Z1	Z2	Z3	L1	L2	L3
324 926	✓	54	28	54	22	35	22	63	59	63
324 933	✓	54	35	54	26	35	26	67	61	67
292 072	✓	54	42	54	29	35	29	69	71	69
292 003	✓	54	54	54	35	35	35	75	75	75

VdS = VdS-Zulassung

Z = Z-Maß

L = Länge

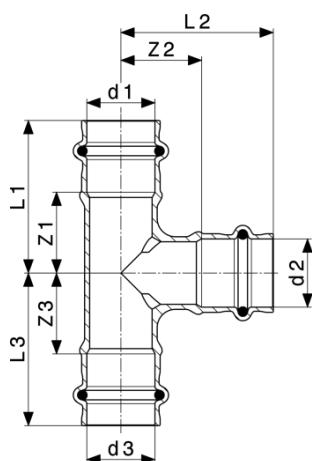

Sanpress-T-Stück
- Rotguss oder Siliziumbronze
Modell 2218

Artikel	d1	d2	d3	Z1	Z2	Z3	L1	L2	L3
314 132	28	28	15	29	29	27	52	52	49
314 163	28	28	18	29	29	27	52	52	49
314 224	42	15	42	23	35	23	59	57	59
283 551	42	35	35	29	37	31	65	62	57
187 279	54	42	42	34	39	37	70	75	77

Z = Z-Maß

L = Länge

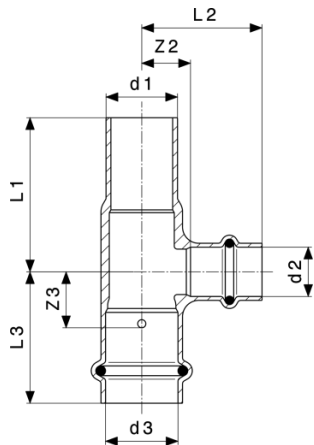

Profipress-T-Stück
- Kupfer
Modell 2418.1

Artikel	d1	d2	d3	Z2	Z3	L1	L2	L3
477 356	22	15	22	15	17	48	37	41

Z = Z-Maß
L = Länge

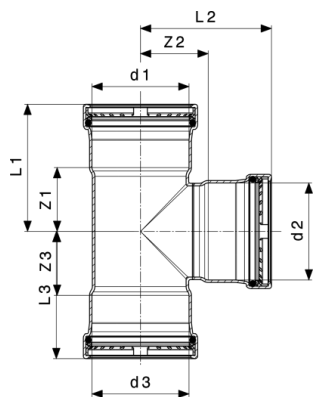

Profipress XL-T-Stück
- Kupfer
Modell 2418XL

Artikel	d1	d2	d3	Z1	Z2	Z3	L1	L2	L3
577 735	64,0	35	64,0	32	42	32	75	69	75
577 742	64,0	42	64,0	35	43	35	78	79	78
577 759	64,0	54	64,0	41	42	41	84	82	84
577 728	64,0	64,0	64,0	46	47	46	89	90	89

Z = Z-Maß
L = Länge

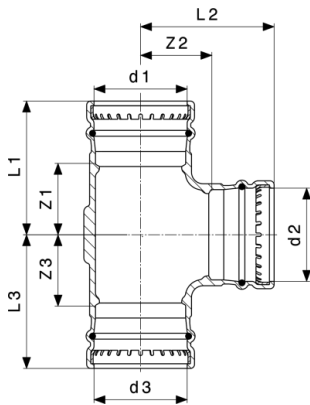

Sanpress XL-T-Stück
- Rotguss
Modell 2218XL

Artikel	d1	d2	d3	Z1	Z2	Z3	L1	L2	L3
354 398	76,1	54	76,1	47	65	47	100	105	100
350 628	76,1	76,1	76,1	61	61	61	114	114	114
354 404	88,9	54	88,9	46	70	46	100	110	100
354 411	88,9	76,1	88,9	62	67	62	115	120	115
350 635	88,9	88,9	88,9	67	67	67	120	120	120
354 428	108,0	54	108,0	47	80	47	110	120	110
354 435	108,0	76,1	108,0	62	77	62	125	130	125
354 442	108,0	88,9	108,0	67	77	67	130	130	130
350 642	108,0	108,0	108,0	77	77	77	140	140	140

Z = Z-Maß
L = Länge

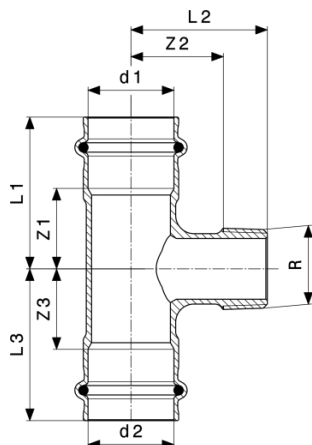

Sanpress-T-Stück
 - Rotguss oder Siliziumbronze
Modell 2217.1

Artikel	d1	R	d2	Z1	Z2	Z3	L1	L2	L3
281 328	18	¾	18	23	26	23	45	40	45
194 123	22	¾	22	27	28	27	50	42	50
194 130	28	¾	28	27	31	27	50	45	50
194 147	35	¾	35	25	31	25	50	45	50
273 231	42	¾	42	19	36	19	55	50	55
197 858	54	¾	54	26	41	26	66	55	66
310 929	54	1	54	29	46	29	69	63	69
310 936	54	1¼	54	32	47	32	72	66	72

Z = Z-Maß

L = Länge

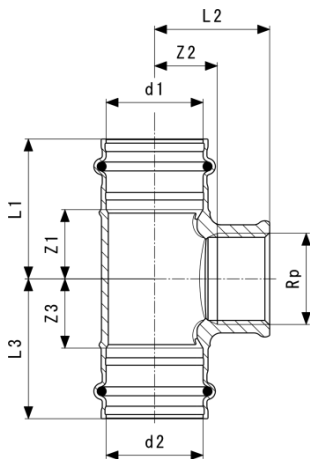

Sanpress-T-Stück
- Rotguss oder Siliziumbronze
Modell 2217.2

Artikel	d1	Rp	d2	Z1	Z2	Z3	L1	L2	L3	SW
290 986	12	½	12	23	10	23	40	20	40	26
313 951	15	¾	15	21	21	21	43	21	43	21
115 630	15	½	15	19	11	19	41	21	41	26
281 359	18	½	18	18	12	18	40	22	40	26
115 944	22	½	22	19	13	19	42	28	42	25
313 975	22	¾	22	25	16	25	49	33	49	31
119 768	28	½	28	21	17	21	45	32	45	25
313 968	28	¾	28	29	19	29	52	35	53	31
121 945	35	½	35	19	25	19	45	35	45	26
361 204	35	1	35	26	23	26	51	42	51	38
126 230	42	½	42	19	35	19	55	50	55	28
361 211	42	1	42	24	31	24	60	50	60	38
197 353	54	½	54	26	40	26	66	55	66	28
361 228	54	1	54	29	47	29	69	66	69	39

Artikel	d1	Rp	d2	Z1*	Z2*	Z3*	L1*	L2*	L3*
290 986	12	½	12						
313 951	15	¾	15						
115 630	15	½	15	23	9	23	45	21	45
281 359	18	½	18	23	25	23	45	40	45
115 944	22	½	22	25	28	25	49	43	49
313 975	22	¾	22						
119 768	28	½	28	25	31	25	49	46	49

Z = Z-Maß
L = Länge
SW = Schlüsselweite
Z* = Vorgängerversion
Z* = Z-Maß der Vorgängerversion

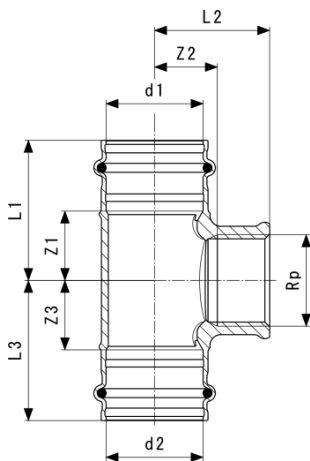

Sanpress-T-Stück
 - Rotguss oder Siliziumbronze
Modell 2217.2

Artikel	d1	Rp	d2	Z1*	Z2*	Z3*	L1*	L2*	L3*
313 968	28	¼	28						
121 945	35	½	35	23	34	23	49	49	49
361 204	35	1	35	26	23	26			
126 230	42	½	42						
361 211	42	1	42	29	37	29	65	59	65
197 353	54	½	54						
361 228	54	1	54						

Z = Z-Maß

L = Länge

SW = Schlüsselweite

Z* = Vorgängerversion

Z* = Z-Maß der Vorgängerversion

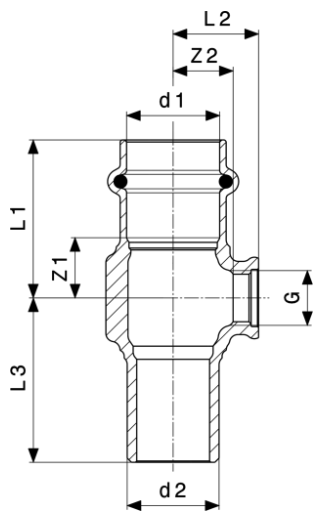

Sanpress-T-Stück
 - Rotguss oder Siliziumbronze
Modell 2217.4

Artikel	d1	G	d2	Z1	Z2	L1	L2	L3
705 596	15	¼	15	14	11	36	18	38
705 602	18	¼	18	14	12	36	19	38
705 619	22	¼	22	15	14	38	21	40
705 626	28	¼	28	17	17	40	24	41
705 633	35	¼	35	15	21	40	28	44
705 640	42	¼	42	16	26	52	32	61
705 855	54	¼	54	20	33	60	39	65

Z = Z-Maß
 L = Länge

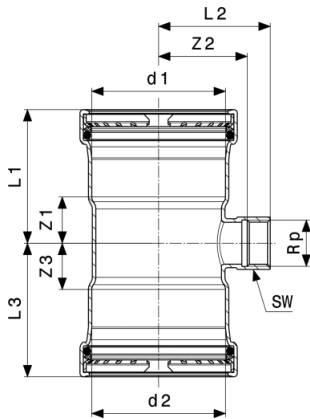

Profipress XL-T-Stück
- Kupfer
Modell 2417.2XL

Artikel	d1	d2	Rp	Z1	Z2	Z3	L1	L2	L3	SW
577 704	64,0	64,0	¾	27	46	27	70	58	70	30
577 711	64,0	64,0	1	32	51	32	75	63	75	38

Z = Z-Maß
L = Länge
SW = Schlüsselweite

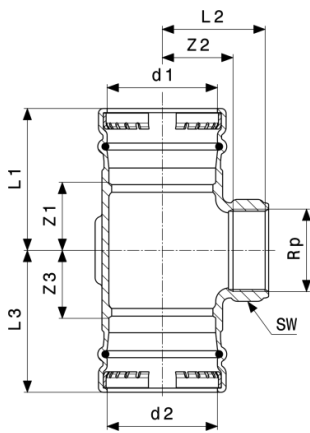

Sanpress XL-T-Stück
- Rotguss
Modell 2217.2XL

Artikel	d1	Rp	d2	Z1	Z2	Z3	L1	L2	L3	SW
354 572	76,1	¾	76,1	30	51	30	85	68	85	32
351 434	76,1	2	76,1	49	51	49	103	77	103	69
354 589	88,9	¾	88,9	32	58	32	85	74	85	32
351 441	88,9	2	88,9	49	57	49	103	83	103	69
354 596	108,0	¾	108,0	32	67	32	95	83	95	32
352 097	108,0	2	108,0	39	67	39	103	93	103	69

Z = Z-Maß
L = Länge
SW = Schlüsselweite

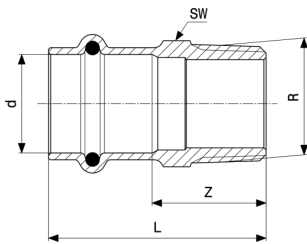

Sanpress-Übergangsstück
 - Rotguss oder Siliziumbronze
Modell 2211

Artikel	d	R	Z	L	SW	Z*	L*	SW*
290 771	12	3/8	18	35	17	17	34	17
290 764	12	1/2	20	37	17	24	38	22
297 985	15	3/8	17	39	19	20	42	
105 044	15	1/2	24	46	19	22	44	22
287 764	15	3/4	28	50	22	26	48	27
283 490	18	1/2	23	45	22	21	43	22
283 230	18	3/4	27	49	22	25	47	27
297 961	22	1/2	25	49	27	22	45	27
104 306	22	3/4	26	49	27	27	50	27
287 771	22	1	33	56	30	32	55	34
297 954	28	3/4	29	52	32			
106 508	28	1	32	55	34			
297 978	28	1 1/4	35	58	34	38	62	42
297 947	35	1	28	53	40	30	56	
110 352	35	1 1/4	34	60	43	36	59	43
314 651	35	1 1/2	37	62	50	35	60	50
297 930	42	1 1/4	29	65	48			
115 340	42	1 1/2	30	66	50	31	67	50
314 668	54	1 1/2	38	78	62			
195 267	54	2	39	79	62			

Z = Z-Maß

L = Länge

SW = Schlüsselweite

Z* = Vorgängerversion

SW* = Vorgängerversion (Schlüsselweite)

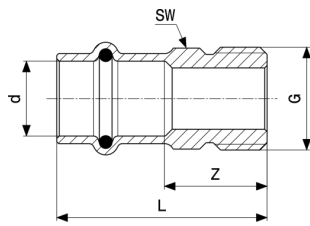

Sanpress-Übergangsstück
- Rotguss oder Siliziumbronze
Modell 2211.4

Artikel	d	G	Z	L	SW
660 222	15	½	21	43	19

Z = Z-Maß
L = Länge
SW = Schlüsselweite

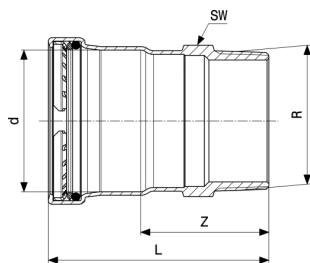

Profipress XL-Übergangsstück
- Kupfer
Modell 2411XL

Artikel	d	R	Z	L	SW
577 674	64,0	2½	70	113	77

Z = Z-Maß
L = Länge
SW = Schlüsselweite

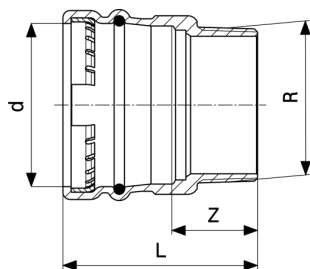

Sanpress XL-Übergangsstück
- Rotguss
Modell 2211XL

Artikel	d	R	Z	L
350 659	76,1	2½	42	95
350 666	88,9	3	47	100
350 673	108,0	4	47	110

Z = Z-Maß
L = Länge

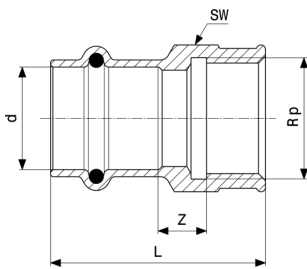

Sanpress-Übergangsstück
 - Rotguss oder Siliziumbronze
Modell 2212

Artikel	d	Rp	Z	L	SW	Z*	L*	SW*
291 075	12	3/8	7	32	21			
291 068	12	1/2	7	39	26			
298 074	15	3/8	8	37	21			
107 543	15	1/2	7	44	26	11	43	
298 098	15	3/4	10	45	31	13		
283 483	18	1/2	4	43	26	10	42	
294 519	18	3/4	10	45	31	12		
298 067	22	1/2	6	44	26	9	42	
108 465	22	3/4	11	47	31		44	
298 128	22	1	14	52	38		49	
428 174	28	1/2	10	44	33			
298 081	28	3/4	12	47	33		46	
114 329	28	1	14	52	38			40
298 104	28	1 1/4	18	55	47			
357 542	35	3/4	10	47	40			
298 111	35	1	8	48	39	9	46	40
116 774	35	1 1/4	14	54	47	15		
298 050	42	1 1/4	12	61	47			
124 236	42	1 1/2	10	69	53	14	64	
365 097	54	1 1/2	13	72	62	11		66
195 304	54	2	15	75	66	14	75	70

Z = Z-Maß
 L = Länge
 SW = Schlüsselweite
 Z* = Vorgängerversion
 SW* = Vorgängerversion (Schlüsselweite)

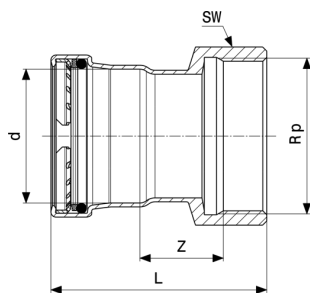

Profipress XL-Übergangsstück
- Kupfer
Modell 2412XL

Artikel	d	Rp	Z	L	SW
577 667	64,0	2½	40	104	82

Z = Z-Maß
L = Länge
SW = Schlüsselweite

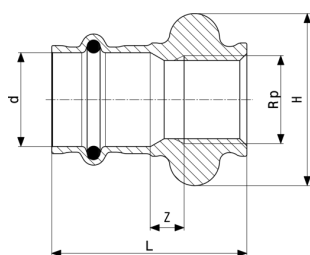

Sanpress-Übergangsstück
- Rotguss oder Siliziumbronze
Modell 2212.3

Artikel	d	Rp	Z	L	H
287 016	15	½	8	45	41
298 913	18	½	9	46	41
287 009	22	½	8	47	41

Z = Z-Maß
L = Länge
H = Höhe

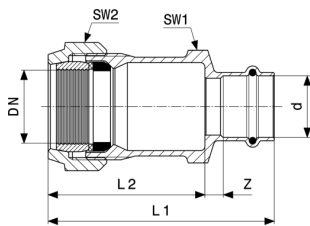

Sanpress-Übergangverschraubung
 - Rotguss oder Siliziumbronze
Modell 2215.6

Artikel	DN	d	Z	L1	L2	SW1	SW2
588 564	25	28	9	104	73	50	55
588 328	32	35	9	112	73	68	70

Z = Z-Maß
 L = Länge
 SW = Schlüsselweite 1
 SW = Schlüsselweite 2

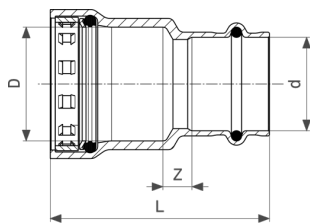

Megapress-Übergangsstück
 - Siliziumbronze
Modell 4213.2

Artikel	DN	D	d	Z	L
736 255	15	½	15	5	55
754 679	15	½	18	4	54
736 279	20	¾	22	5	58
736 293	25	1	28	9	67
736 309	32	1¼	35	6	78
736 316	40	1½	42	7	90
736 323	50	2	54	8	98

Z = Z-Maß
 L = Länge

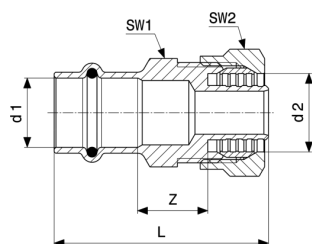

Sanpress-Übergangverschraubung
- Rotguss
Modell 2213

Artikel	d1	d2	L	Z	SW1	SW2
288 068	15	16	54	16	24	26

L = Länge
Z = Z-Maß
SW = Schlüsselweite 1
SW = Schlüsselweite 2

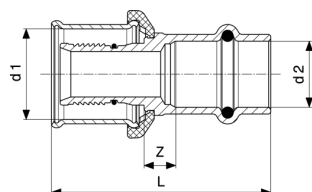

Sanfix P-Übergangsstück
- Rotguss
Modell 2213P

Artikel	d1	d2	L	Z
317 423	16	15	48	6
317 447	16	18	51	9
317 430	20	15	51	7
317 454	20	18	52	8
317 508	20	22	54	9
605 490	25	22	56	8
605 506	32	28	61	9
605 520	40	35	65	9

L = Länge
Z = Z-Maß

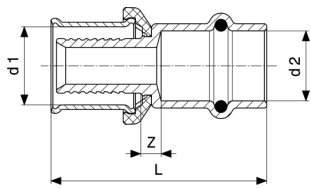

Profipress-Übergangsstück
- Rotguss
Modell 1075.12P

Artikel	d1	d2	Z	L
314 958	14	15	6	49

Z = Z-Maß
L = Länge

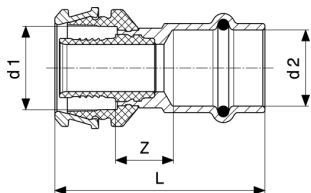

Raxofix-Übergangsstück
- Siliziumbronze
Modell 5313P

Artikel	d1	d2	Z	L
646 707	16	15	13	50
646 714	16	18	14	51
646 721	20	15	13	50
646 738	20	18	14	51
646 745	20	22	15	53
646 752	25	22	16	59
646 769	32	28	15	59
646 776	40	28	21	71
646 783	40	35	18	70
646 790	50	35	24	76

Z = Z-Maß
L = Länge

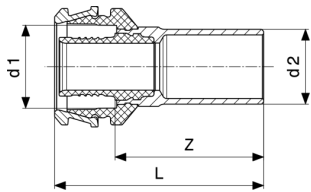

Raxofix-Einsteckstück
- Siliziumbronze
Modell 5313

Artikel	d1	d2	Z	L
646 554	16	15	36	51
646 561	16	18	37	52
646 578	20	18	36	51
646 585	20	22	39	54
646 592	25	22	40	60
646 608	32	28	41	61
646 615	40	35	47	74
646 622	50	42	62	89

Z = Z-Maß
L = Länge

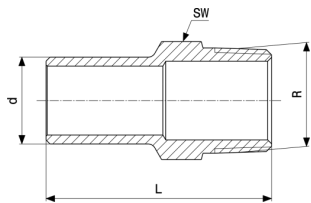

Sanpress-Einsteckstück
- Rotguss oder Siliziumbronze
Modell 2211.1

Artikel	d	R	L	SW
291 310	12	½	47	22
115 418	15	½	49	22
285 081	18	½	50	22
285 104	18	¾	56	27
119 676	22	½	53	22
116 767	22	¾	58	27
122 034	28	1	62	34
125 288	35	1¼	66	43
132 231	42	1½	78	50

L = Länge
SW = Schlüsselweite

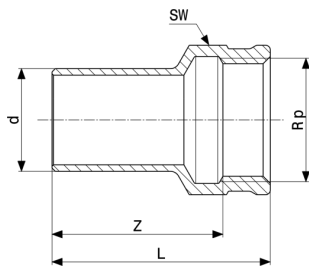

Sanpress-Einsteckstück
- Rotguss oder Siliziumbronze
Modell 2212.1

Artikel	d	Rp	Z	L	SW
291 341	12	½	31	40	25
117 733	15	½	34	44	25
287 085	18	½	34	43	25
287 108	18	¾	35	45	31
120 917	22	½	36	45	25
117 481	22	¾	37	47	31
130 954	28	¾	37	47	31
122 942	28	1	39	51	38
134 730	35	1	42	54	38
130 589	35	1¼	46	59	47
135 430	42	1½	57	70	53
199 104	54	2	63	80	70

Z = Z-Maß

L = Länge

SW = Schlüsselweite

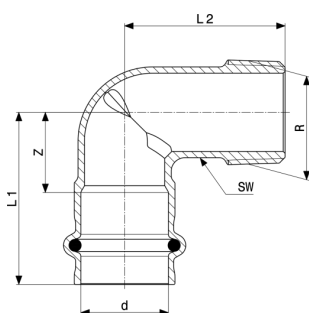

Sanpress-Übergangsbogen 90°
- Rotguss oder Siliziumbronze
Modell 2214

Artikel	d	R	Z	L1	L2	SW	Z*	L1*	L2*
290 863	12	⅜	14	31	31	15	19	37	40
290 870	12	½	19	37	37	17	19	37	44
314 361	15	⅝	18	40	40	17	23	45	47

Z = Z-Maß

L = Länge

SW = Schlüsselweite

Z* = Vorgängerversion

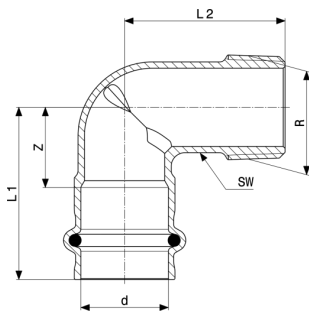

Sanpress-Übergangsbogen 90°
- Rotguss oder Siliziumbronze
Modell 2214

Artikel	d	R	Z	L1	L2	SW	Z*	L1*	L2*
112 950	15	½	17	39	35	19	23	45	43
443 030	15	¾	24	46	55	25	29	51	59
281 205	18	½	20	42	42	19	20	46	50
314 354	18	¾	24	46	55	25			
115 623	22	¾	21	44	41	25	28	51	59
118 730	28	1	35	58	58	31			72
127 329	35	1¼	33	58	58	39	48	74	88
128 500	42	1½	29	65	60	51	20	42	42
197 988	54	2	43	83	80	55	70	110	120

Z = Z-Maß
L = Länge
SW = Schlüsselweite
Z* = Vorgängerversion

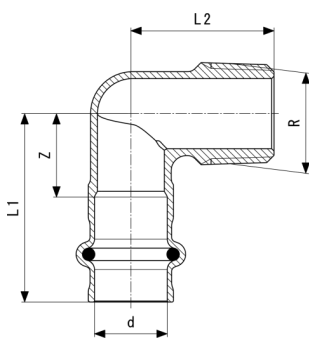

Sanpress-Übergangswinkel 90°
- Rotguss oder Siliziumbronze
Modell 2214.1

Artikel	d	R	Z	L1	L2
335 281	15	½	18	40	30

Z = Z-Maß
L = Länge

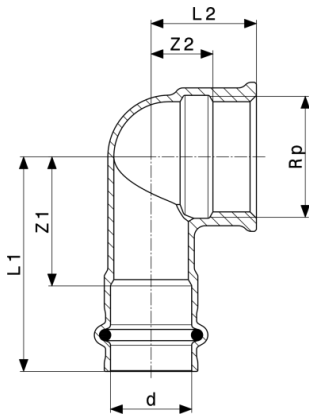

Sanpress-Übergangswinkel 90°
 - Rotguss oder Siliziumbronze
Modell 2214.2

Artikel	d	Rp	Z1	Z2	L1	L2	Z1*	Z2*	L1*	L2*
290 924	12	3/8	21	9	38	17				
290 931	12	1/2	23	10	40	20				
298 241	15	3/8	24	11	46	19				
108 441	15	1/2	22	12	44	22	24	12	46	22
314 385	15	3/4	28	14	50	25				
281 236	18	1/2	24	12	46	22				
298 227	18	3/4	28	13	50	24				
298 234	22	1/2	29	16	52	26				
283 711	22	3/4	29	16	52	27				
314 378	22	1	36	17	59	29				
442 033	28	1/2	33	23	56	32				
446 611	28	3/4	35	16	58	27				
283 728	28	1	36	20	59	33				
283 704	35	1 1/4	41	25	66	39				
299 415	42	1 1/2	41	29	77	43				
299 422	54	2	57	37	97	55				

Z = Z-Maß

L = Länge

Z* = Vorgängerversion

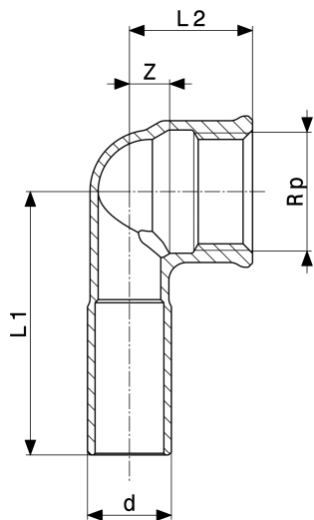

Sanpress-Einsteckwinkel 90°
 - Rotguss oder Siliziumbronze
Modell 2214.3

Artikel	d	Rp	Z	L1	L2
308 001	15	½	12	47	22

Z = Z-Maß
 L = Länge

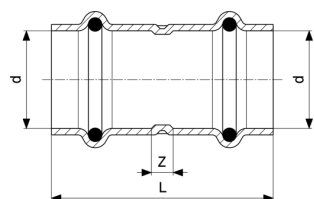

Profipress-Muffe
 - Kupfer
Modell 2415

Artikel	d	Z	L
292 737	12	3	39
292 690	15	3	47
292 744	18	5	49
292 683	22	5	51
292 676	28	4	52
292 706	35	4	56
292 713	42	4	76
292 720	54	4	84

Z = Z-Maß
 L = Länge

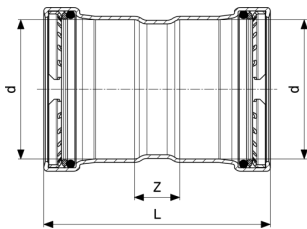

Profipress XL-Muffe
- Kupfer
Modell 2415XL

Artikel	d	Z	L
577 582	64,0	24	110

Z = Z-Maß
L = Länge

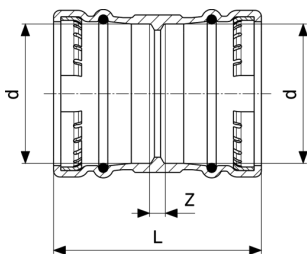

Sanpress XL-Muffe
- Rotguss
Modell 2215XL

Artikel	d	Z	L
350 598	76,1	9	115
350 604	88,9	9	115
350 611	108,0	9	135

Z = Z-Maß
L = Länge

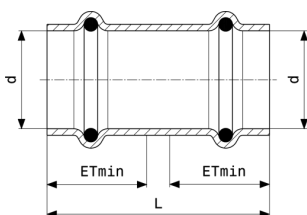

Profipress-Schiebemuffe
- Kupfer
Modell 2415.3

Artikel	d	L	ETmin
713 416	12	39	18
461 256	15	47	22
461 263	18	49	22
461 270	22	51	23
461 287	28	52	24

L = Länge
ETmin = Einstecktiefe minimal

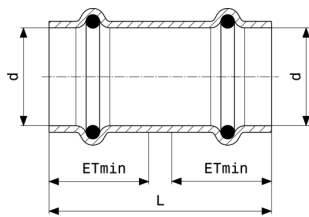

Profipress-Schiebemuffe
- Kupfer
Modell 2415.3

Artikel	d	L	ETmin
461 294	35	56	26
461 317	42	76	36
461 300	54	84	40

L = Länge

ETmin = Einstecktiefe minimal

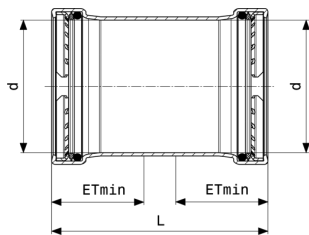

Profipress XL-Schiebemuffe
- Kupfer
Modell 2415.5XL

Artikel	d	L	ETmin
577 650	64,0	110	43

L = Länge

ETmin = Einstecktiefe minimal

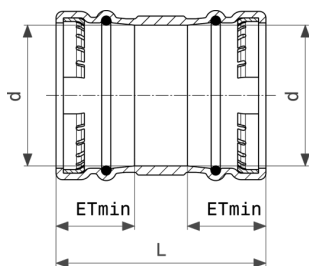

Sanpress XL-Schiebemuffe
- Rotguss
Modell 2215.5XL

Artikel	d	L	ETmin
353 315	76,1	115	43
353 322	88,9	115	43
353 339	108,0	135	43

L = Länge

ETmin = Einstecktiefe minimal

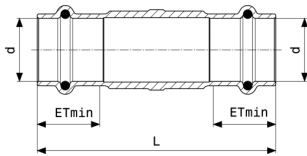

Sanpress-Schiebemuffe
- Rotguss oder Siliziumbronze
Modell 2215.5

Artikel	d	L	ETmin
119 485	15	80	22
287 061	18	80	22
119 041	22	85	24
122 133	28	95	24
124 335	35	105	26
131 494	42	120	36
216 153	54	134	48

L = Länge

ETmin = Einstecktiefe minimal

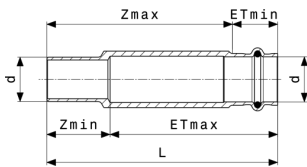

Sanpress-Schiebemuffe
- Rotguss oder Siliziumbronze
Modell 2215.4

Artikel	d	L	ETmax	ETmin	Zmax	Zmin
588 533	22	115	84	23	90	32
588 540	28	125	93	26	93	32
588 557	35	135	100	25	99	36

L = Länge

ETmax = Einstecktiefe maximal

ETmin = Einstecktiefe minimal

Zmax = Z-Maß maximal

Zmin = Z-Maß minimal

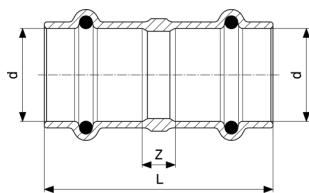

Sanpress-Muffe
- Rotguss
Modell 9777.9

Artikel	d	Z	L
335 946¹	10	5	40

Z = Z-Maß

L = Länge

¹⁾ Pressverbindung d10 ist mit einer 12er-Pressbacke auszuführen.

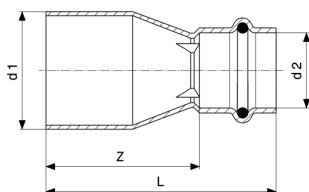

Profipress-Reduzierstück
- Kupfer
Modell 2415.1

Artikel	d1	d2	Z	L
443 771	14	12	24	42
296 414	15	12	32	50
298 586	18	12	35	53
443 801	18	14	33	52
296 407	18	15	32	54
443 825	22	14	36	55
296 377	22	15	36	58
296 391	22	18	33	55
296 469	28	15	43	65
296 384	28	18	39	61
296 506	28	22	31	54
296 452	35	22	46	69
296 490	35	28	39	63
296 445	42	22	69	92
296 483	42	28	63	87
296 476	42	35	56	82
366 476	54	28	79	103
296 438	54	35	71	97
296 421	54	42	62	99

Z = Z-Maß

L = Länge

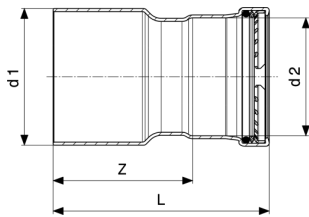

Profipress XL-Reduzierstück
- Kupfer
Modell 2415.1XL

Artikel	d1	d2	Z	L
577 605	64,0	42	67	103
577 612	64,0	54	70	110
587 505	76,1	64,0	92	135

Z = Z-Maß
L = Länge

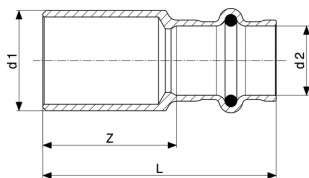

Sanpress-Reduzierstück
- Rotguss oder Siliziumbronze
Modell 2215.1

Artikel	d1	d2	Z	L	Z*	L*
366 865	22	12	30	47	26	43

Z = Z-Maß
L = Länge
Z* = Vorgängerversion

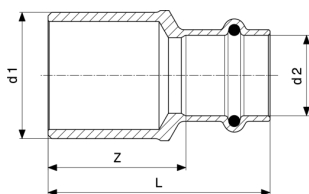

Sanpress-Reduzierstück
- Rotguss oder Siliziumbronze
Modell 2215.1NC

Artikel	d1	d2	Z	L
323 707¹	15	14	29	52

Z = Z-Maß
L = Länge

¹⁾ Pressverbindung d14 ist mit einer 15er-Pressbacke auszuführen.

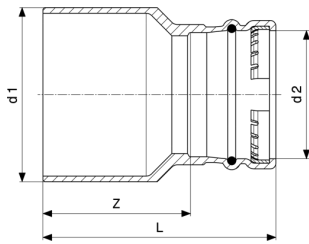

Sanpress XL-Reduzierstück
- Rotguss
Modell 2215.1XL

Artikel	d1	d2	Z	L
354 664	76,1	54	81	121
354 671	88,9	54	86	126
354 688	88,9	76,1	72	125
354 695	108,0	54	106	146
354 701	108,0	76,1	92	145
354 718	108,0	88,9	87	140

Z = Z-Maß
L = Länge

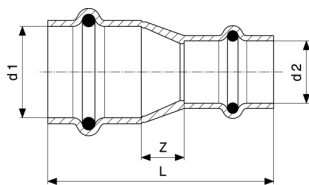

Profipress-Reduziermuffe
- Kupfer
Modell 2415.2

Artikel	d1	d2	Z	L
325 770	15	12	8	48
325 787	18	15	9	53
325 794	22	15	11	56
325 800	22	18	9	54
325 817	28	22	11	58
328 269	35	28	13	63
328 252	42	35	13	75
328 276	54	42	19	95

Z = Z-Maß
L = Länge

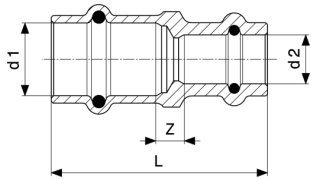

Sanpress-Reduziermuffe
- Rotguss
Modell 9778.0

Artikel	d1	d2	Z	L
335 953¹	12	10	5	40

Z = Z-Maß

L = Länge

1) Pressverbindung d10 ist mit einer 12er-Pressbacke auszuführen.

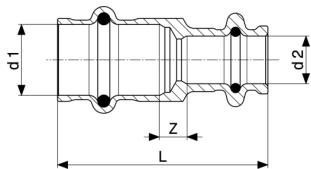

Sanpress-Reduziermuffe
- Rotguss
Modell 9778.1

Artikel	d1	d2	Z	L
335 960¹	15	10	6	46

Z = Z-Maß

L = Länge

1) Pressverbindung d10 ist mit einer 12er-Pressbacke auszuführen.

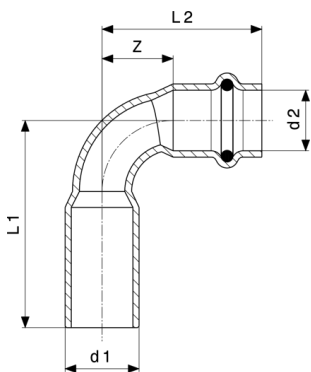

Profipress-Reduzierbogen 90°
- Kupfer
Modell 2416.2

Artikel	d1	d2	Z	L1	L2
629 281	15	12	14	32	42

Z = Z-Maß

L = Länge

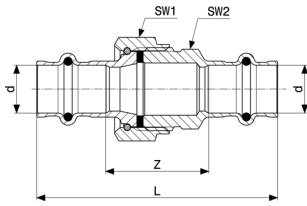

Sanpress-Verschraubung
- Rotguss oder Siliziumbronze
Modell 2260

Artikel	d	Z	L	SW1	SW2
293 017	12	30	65	24	30
126 148	15	33	77	24	30
287 436	18	36	80	24	30
126 124	22	42	89	31	37
124 311	28	48	95	40	46
130 947	35	49	100	45	53
132 446	42	49	121	50	60
226 329	54	49	129	70	78

Z = Z-Maß

L = Länge

SW = Schlüsselweite 1

SW = Schlüsselweite 2

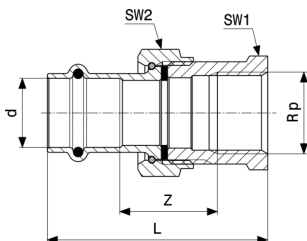

Sanpress-Übergangverschraubung
- Rotguss oder Siliziumbronze
Modell 2262

Artikel	d	Rp	Z	L	SW1	SW2
293 024	12	½	23	56	27	30
131 937	15	½	26	63	27	30
133 160	15	¾	33	66	31	30
283 384	18	½	28	65	27	30
314 910	18	¾	36	68	31	30
125 318	22	¾	32	72	34	37
133 900	22	1	42	78	40	37
365 103	28	¾	23	63	32	46
128 975	28	1	33	76	44	46

Z = Z-Maß

L = Länge

SW = Schlüsselweite 1

SW = Schlüsselweite 2

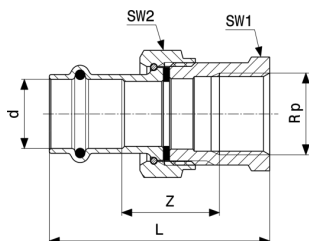

Sanpress-Übergangverschraubung
- Rotguss oder Siliziumbronze
Modell 2262

Artikel	d	Rp	Z	L	SW1	SW2
138 875	35	1¼	36	83	50	53
141 745	42	1½	38	96	56	60
222 017	54	2	27	84	66	78

Z = Z-Maß

L = Länge

SW = Schlüsselweite 1

SW = Schlüsselweite 2

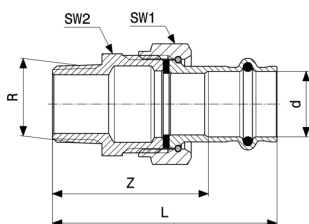

Sanpress-Übergangverschraubung
- Rotguss oder Siliziumbronze
Modell 2265

Artikel	d	R	Z	L	SW1	SW2
291 372	12	⅜	40	58	30	27
291 389	12	½	44	61	30	27
120 108	15	½	46	68	30	27
140 878	15	¾	47	69	30	27
283 360	18	½	49	71	30	27
283 377	18	¾	50	72	30	27
142 674	22	½	50	74	37	34
119 133	22	¾	54	77	37	34
148 492	22	1	54	78	37	34
365 110	28	¾	58	82	46	44
120 047	28	1	59	83	46	44
128 425	35	1¼	63	89	53	50
135 966	42	1½	69	105	60	55
221 997	54	2	67	107	78	70

Z = Z-Maß

L = Länge

SW = Schlüsselweite 1

SW = Schlüsselweite 2

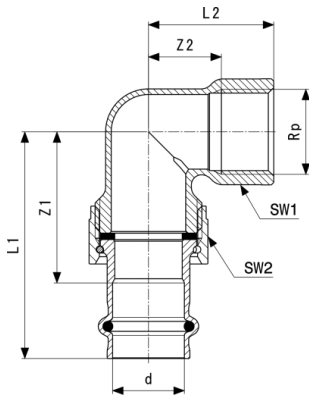

Sanpress-Übergangverschraubung 90°
 - Rotguss oder Siliziumbronze
Modell 2255

Artikel	d	Rp	Z1	Z2	L1	L2	SW1	SW2
292 980*	12	½	36	18	53	33	28	30
125 660	15	½	38	18	60	33	28	30
283 469	18	½	41	17	63	28	28	30
283 452	18	¾	43	22	65	33	33	36
122 614	22	¾	47	22	71	33	33	37
132 637	22	1	50	25	74	44	40	37
128 159	28	1	57	28	81	47	39	46
132 729	35	1¼	60	35	85	57	47	53
139 872	42	1½	72	38	108	59	55	60
221 676	54	2	74	43	114	69	69	78

Z = Z-Maß

L = Länge

SW = Schlüsselweite 1

SW = Schlüsselweite 2

* = Lieferung nur noch aus Lagervorrat

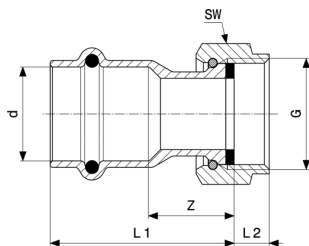

Sanpress-Anschlussverschraubung
 - Rotguss oder Siliziumbronze
Modell 2263

Artikel	VdS	d	G	Z	L1	L2	SW
475 956		12	¾	17	35	7	22
380 878		12	½	13	31	7	24
293 611		12	¾	10	27	9	30

VdS = VdS-Zulassung

Z = Z-Maß

L = Länge

SW = Schlüsselweite

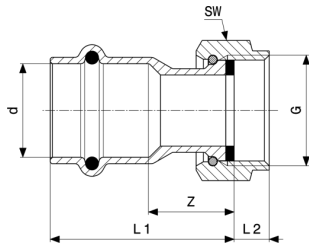

Sanpress-Anschlussverschraubung
 - Rotguss oder Siliziumbronze
Modell 2263

Artikel	VdS	d	G	Z	L1	L2	SW
475 963		15	3/8	19	41	7	22
380 885		15	1/2	15	37	7	24
265 663		15	3/4	12	34	8	30
305 000		15	1	11	33	8	36
424 534		15	1 1/4	14	36	12	50
283 391		18	3/4	15	37	8	30
305 017		18	1	11	33	8	36
351 502		22	3/4	21	44	8	30
265 687	✓	22	1	16	39	8	37
367 015	✓	22	1 1/4	13	37	11	50
305 260	✓	22	1 1/2	13	37	8	52
692 629		28	1	19	42	8	37
265 700	✓	28	1 1/4	18	42	10	46
305 048	✓	28	1 1/2	15	39	11	52
265 731	✓	35	1 1/2	18	44	10	53
305 024	✓	35	2	14	39	12	65
265 304	✓	42	1 3/4	22	58	11	60
305 031	✓	42	2	20	56	14	66
426 743	✓	54	2 1/4	22	62	14	72
265 328	✓	54	2 3/8	13	53	12	78
341 961	✓	54	2 1/2	17	57	16	88
426 750	✓	54	2 3/4	16	56	17	88

VdS = VdS-Zulassung
 Z = Z-Maß
 L = Länge
 SW = Schlüsselweite

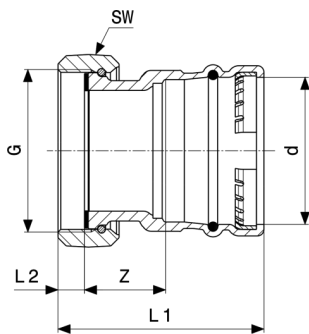

Sanpress XL-Anschlussverschraubung
 - Rotguss
Modell 2263XL

Artikel	d	G	Z	L1	L2	SW
365 127	76,1	3	42	111	14	98
365 134	88,9	3½	42	111	14	112

Z = Z-Maß
 L = Länge
 SW = Schlüsselweite

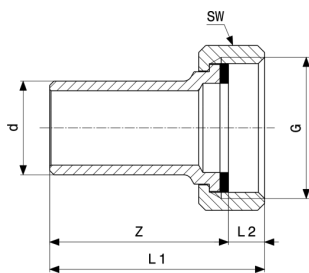

Sanpress-Anschlussverschraubung
 - Rotguss oder Siliziumbronze
Modell 2264

Artikel	d	G	Z	L1	L2	SW
338 503	15	¾	41	49	8	29
338 510	18	¾	41	49	8	29
338 527	22	1	42	51	9	36
338 534	28	1¼	44	53	9	46
338 541	35	1½	46	56	10	52
338 558	42	1¾	63	74	11	59
338 565	54	2¾	55	68	13	75

Z = Z-Maß
 L = Länge
 SW = Schlüsselweite

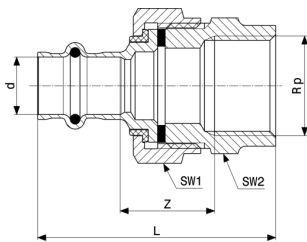

Sanpress-Isolierschraubung
 - Rotguss oder Siliziumbronze
Modell 2267

Artikel	d	Rp	Z	L	SW1	SW2
469 450	15	1/2	18	55	37	34
469 467	15	3/4	25	64	37	34
469 474	18	1/2	20	58	46	44
469 481	18	3/4	19	58	46	44
469 498	22	3/4	21	63	55	50
469 504	22	1	23	65	55	50
469 511	28	1	23	65	55	50
469 528	35	1 1/4	21	68	70	62
469 535	42	1 1/2	19	77	73	68
469 542	54	2	24	90	88	83

Z = Z-Maß

L = Länge

SW = Schlüsselweite 1

SW = Schlüsselweite 2

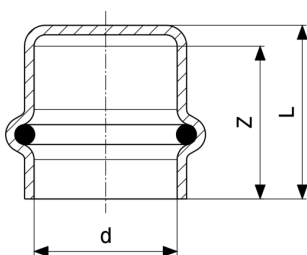

Profipress-Kappe
 - Kupfer
Modell 2456

Artikel	d	Z	L
349 295	12	20	23
349 301	15	22	25
349 363	18	24	27
349 356	22	25	28
349 349	28	26	29
349 332	35	29	32
349 325	42	38	42

Z = Z-Maß

L = Länge

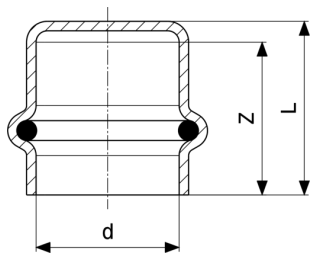

Profipress-Kappe
- Kupfer
Modell 2456

Artikel	d	Z	L
349 318	54	42	46

Z = Z-Maß
L = Länge

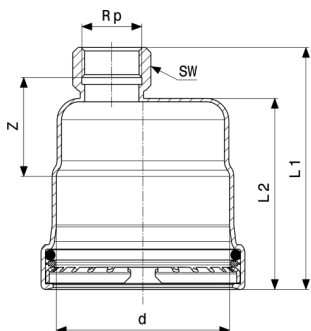

Profipress XL-Kappe
- Kupfer
Modell 2456XL

Artikel	d	Rp	Z	L1	L2	SW
577 780	64,0	¾	45	100	78	30

Z = Z-Maß
L = Länge
SW = Schlüsselweite

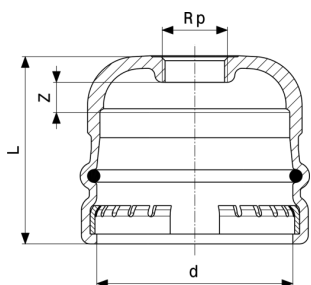

Sanpress XL-Kappe
- Rotguss
Modell 2256XL

Artikel	d	Rp	Z	L
353 377	76,1	¾	12	76
353 384	88,9	¾	11	77
353 391	108,0	¾	15	89

Z = Z-Maß
L = Länge

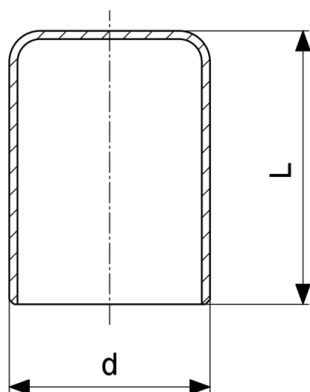

Profipress-Stopfen
- Kupfer
Modell 2457

Artikel	d	L
330 903	15	29
330 897	18	29
314 576	22	30
314 569	28	31
314 545*	42	46
314 538*	54	55

L = Länge

* = Lieferung nur noch aus Lagervorrat

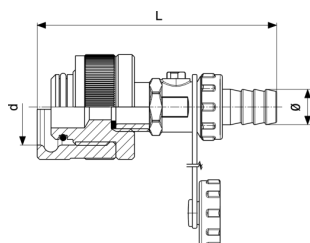

Abdruckstopfen
- Messing
Modell 2269

Artikel	d	L	Ø
290 801	12	117	15
141 523	15	120	15
289 423	18	120	15
140 557	22	119	15
142 568	28	131	15
144 111	35	102	15
144 999	42	107	15
187 798	54	127	15

L = Länge

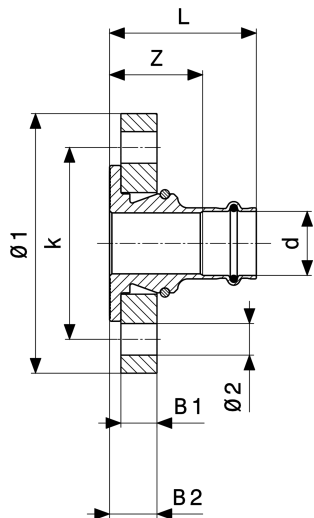

Sanpress-Flanschübergang
 - Rotguss oder Siliziumbronze
Modell 2259.5

Artikel	DN	d	Z	L	B1	B2	Ø1	Ø2	k	n
479 855	25	28	42	65	16	21	115	14	85	4
479 879	32	35	45	70	16	21	140	18	100	4
479 886	40	42	47	83	16	21	150	18	110	4
479 893	50	54	50	90	16	21	165	18	125	4

Z = Z-Maß

L = Länge

B = Breite

Ø = Durchmesser

k = Lochkreis-Ø

n = Anzahl Bohrungen

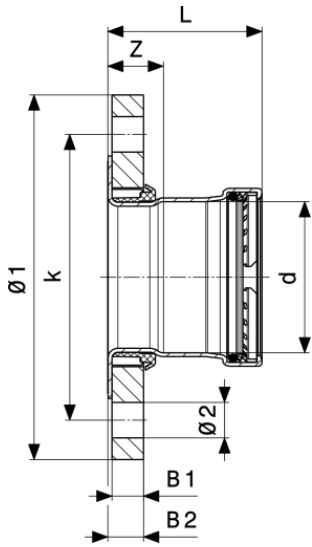

Profipress XL-Flanschübergang
 - Kupfer
Modell 2459.5XL

Artikel	DN	d	Z	L	B1	B2	Ø1	k	Ø2	n
577 797	65	64,0	28	71	16	18	185	145	18	8

Z = Z-Maß
 L = Länge
 B = Breite
 Ø = Durchmesser
 k = Lochkreis-Ø
 n = Anzahl Bohrungen

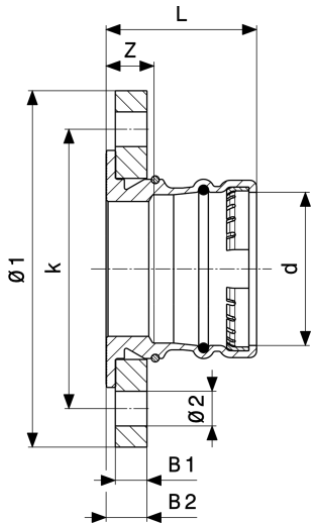

Sanpress XL-Flanschübergang
 - Rotguss
Modell 2259.5XL

Artikel	DN	d	Z	L	B1	B2	Ø1	Ø2	k	n
479 954	65	76,1	25	78	16	21	185	18	145	8
479 978	80	88,9	27	80	18	23	200	18	160	8
480 011	100	108,0	17	80	18	23	220	18	180	8

Z = Z-Maß

L = Länge

B = Breite

Ø = Durchmesser

k = Lochkreis-Ø

n = Anzahl Bohrungen

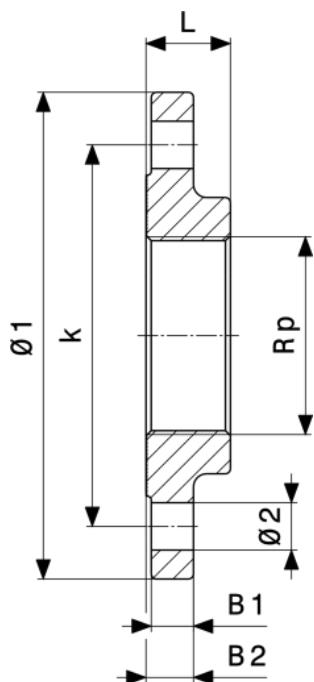

Sanpress XL-Flansch
 - Rotguss oder Siliziumbronze
Modell 2259.2XL

Artikel	DN	Rp	Ø1	L	B1	B2	Ø2	k	n
641 597	65	2½	185	32	16	18	18	145	8
641 603	80	3	200	34	18	20	18	160	8
641 610	100	4	220	38	18	20	18	180	8

Ø = Durchmesser
 L = Länge
 B = Breite
 k = Lochkreis-Ø
 n = Anzahl Bohrungen

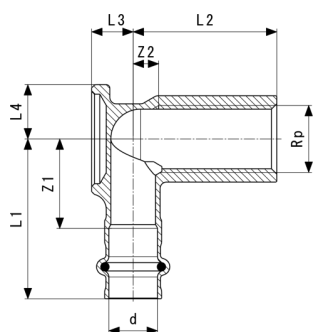

Sanpress-Wandscheibe
 - Rotguss oder Siliziumbronze
Modell 2225

Artikel	d	Rp	L	Z1	Z2	L1	L2	L3	L4
116 552	15	½	45	28	8	50	45	13	21

Z = Z-Maß
 L = Länge

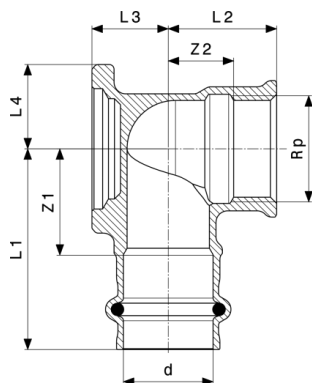

Sanpress-Wandscheibe
 - Rotguss oder Siliziumbronze
Modell 2225.5

Artikel	d	Rp	Z1	Z2	L1	L2	L3	L4	Z1*	Z2*
291 013	12	½	23	10	40	20	11	18		
107 345	15	½	22	12	44	22	13	17	24	12
281 502	18	½	22	12	44	22	15	18	24	12
335 236	18	¾	28	13	50	24	16	21		
335 229	22	½	27	14	50	24	18	18		
116 057	22	¾	27	16	50	27	19	21		

Artikel	d	Rp	L1*	L2*	L3*	L4*
291 013	12	½				
107 345	15	½	46	21	13	22
281 502	18	½	46	21	15	22
335 236	18	¾				
335 229	22	½				
116 057	22	¾				

Z = Z-Maß
 L = Länge
 Z* = Vorgängerversion

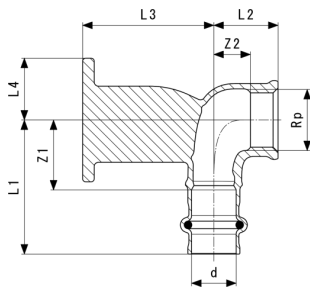

Sanpress-Wandscheibe
- Rotguss oder Siliziumbronze
Modell 2225.6

Artikel	d	Rp	Z1	Z2	L1	L2	L3	L4
347 307	15	½	24	13	46	22	45	21

Z = Z-Maß
L = Länge

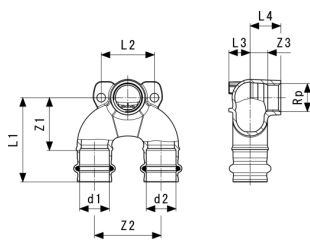

Sanpress-Doppelwandscheibe
- Rotguss oder Siliziumbronze
Modell 2228.7

Artikel	d1	Rp	d2	Z1	Z2	Z3	L1	L2	L3	L4
687 892	15	½	15	34	50	10	56	40	13	23
692 797	18	½	18	34	50	10	56	40	14	23
687 908	22	½	22	40	50	12	63	40	16	23

Z = Z-Maß
L = Länge

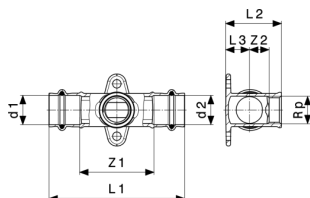

Sanpress-Wandscheiben-T-Stück
- Rotguss oder Siliziumbronze
Modell 2217.3

Artikel	d1	Rp	d2	Z1	Z2	L1	L2	L3
644 864	15	½	15	48	14	92	36	13
625 726	22	½	22	57	15	104	43	19

Z = Z-Maß
L = Länge

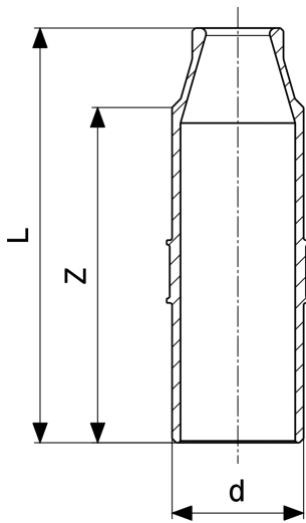

Einpressdüse
- Rotguss oder Siliziumbronze
Modell 2211.5

Artikel	d	Z	L
695 835	22	54	69
695 842	28	57	74
696 252	35	61	77
696 269	42	81	100
696 276	54	89	113
696 283*	64	103	122

Z = Z-Maß

L = Länge

* = Lieferung nur noch aus Lagervorrat

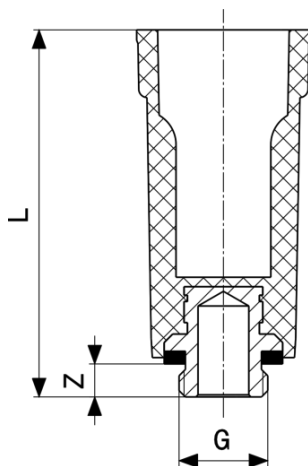

Abdruckstopfen
- Kunststoff
Modell 1516.113

Artikel	G	Z	L
116 644	3/8	7	85
100 766	1/2	11	92
107 666	3/4	9	87

Z = Z-Maß
L = Länge

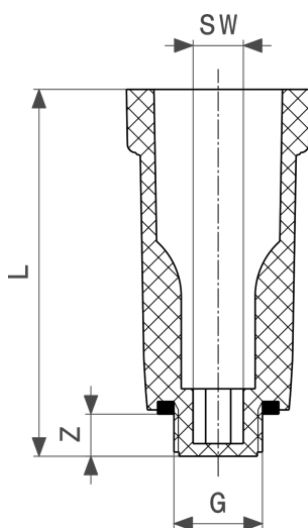

Abdruckstopfen
- Kunststoff
Modell 1516

Artikel	G	Z	L	SW
107 796	3/8	10	87	8
100 124	1/2	10	87	10
102 746	3/4	13	90	14

Z = Z-Maß
L = Länge
SW = Schlüsselweite

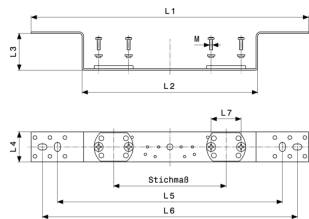

Halterung
- Stahl verzinkt
Modell 2021.7

Artikel	Stichmaß	L1	L2	L3	L4	L5	L6	L7	M
651 350	70/100/150	370	234	48	40	300	340	40	4

L = Länge
M = Gewindeart

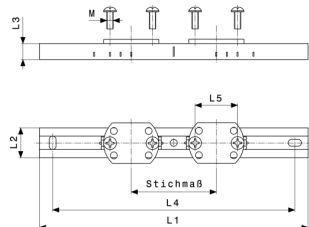

Halterung
- Stahl verzinkt
Modell 2141.3

Artikel	Stichmaß	L1	L2	L3	L4	L5	M
581 701	80-150	253	28	15	228	40	6

L = Länge
M = Gewindeart

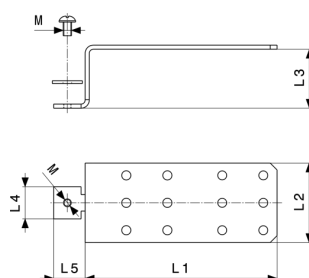

Halterung
- Stahl verzinkt
Modell 2141.4

Artikel	L1	L2	L3	L4	L5	M
586 706	140	58	43	24	23	6

L = Länge
M = Gewindeart

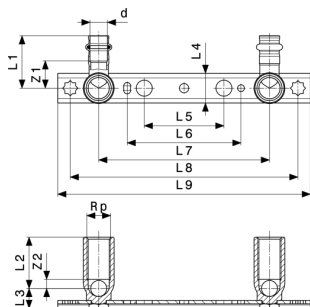

**Sanpress-Montageeinheit
Modell 2221**

Artikel	d	Rp	L	Stichmaß	Z1	Z2	L1	L2	L3	L4
124 502	15	½	45	150/200	24	8	46	45	18	26

Artikel	d	Rp	L	Stichmaß	L5	L6	L7	L8	L9
124 502	15	½	45	150/200	70	100	150	200	222

Z = Z-Maß
L = Länge

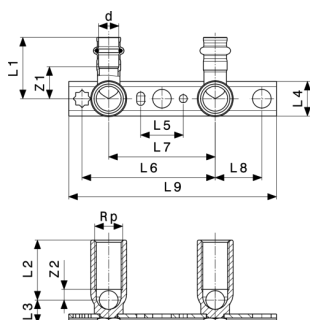

**Sanpress-Montageeinheit
Modell 2221.1**

Artikel	d	Rp	L	Stichmaß	Z1	Z2	L1	L2	L3	L4
135 119	15	½	45	80/100	24	8	46	45	18	26

Artikel	d	Rp	L	Stichmaß	L5	L6	L7	L8	L9
135 119	15	½	45	80/100	32	100	80	35	156

Z = Z-Maß
L = Länge

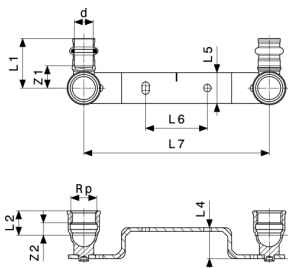

**Sanpress-Montageeinheit
Modell 2222**

Artikel	d	Rp	Stichmaß	Z1	Z2	L1	L2	L3	L4	L5
295 462	15	½	150	24	12	40	22	17	25	25

Artikel	d	Rp	Stichmaß	L6	L7
295 462	15	½	150	50	150

Z = Z-Maß
L = Länge

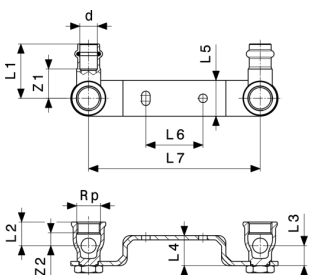

**Sanpress-Montageeinheit
Modell 2222.6EX**

Artikel	d	Rp	Stichmaß	Z1	Z2	L1	L2	L3	L4	L5
357 351	12	¾	120	21	9	38	17	14	21	25

Artikel	d	Rp	Stichmaß	L6	L7
357 351	12	¾	120	40	120

Z = Z-Maß
L = Länge

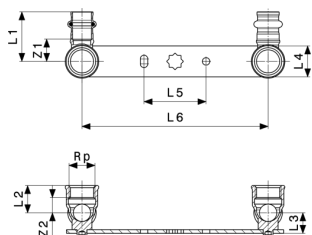

**Sanpress-Montageeinheit
Modell 2222.05**

Artikel	d	Rp	Stichmaß	Z1	Z2	L1	L2	L3	L4	L5
308 681	15	½	150	18	12	40	22	17	25	50

Artikel	d	Rp	Stichmaß	L6
308 681	15	½	150	150

Z = Z-Maß
L = Länge

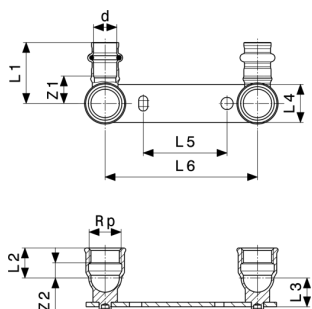

**Sanpress-Montageeinheit
Modell 2222.2**

Artikel	d	Rp	Stichmaß	Z1	Z2	L1	L2	L3	L4	L5
308 674	15	½	100	18	12	40	22	17	25	55

Artikel	d	Rp	Stichmaß	L6
308 674	15	½	100	100

Z = Z-Maß
L = Länge

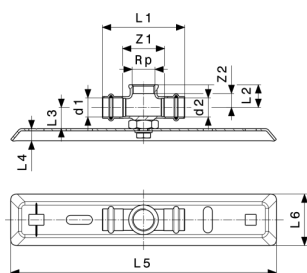

**Sanpress-Montageeinheit
Modell 2218.4**

Artikel	d1	Rp	d2	Z1	Z2	L1	L2	L3	L4	L5
625 078*	22	¾	22	49	16	96	27	25	14	310

Artikel	d1	Rp	d2	L6
625 078*	22	¾	22	60

Z = Z-Maß

L = Länge

* = Lieferung nur noch aus Lagervorrat

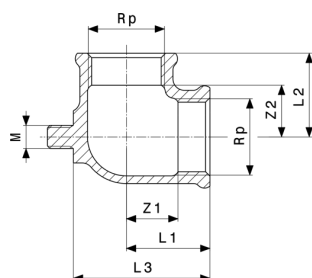

**Anschlusswinkel 90°
- Rotguss oder Siliziumbronze
Modell 94477.0-713**

Artikel	Rp	Z1	Z2	L1	L2	L3	M
374 570 ¹	½	15	15	25	25	41	8
489 298 ¹	¾	18	18	29	29	47	8
138 066 ²	1	15	15	35	35	57	8

Z = Z-Maß

L = Länge

M = Gewindeart

1) Rotguss

2) Messing

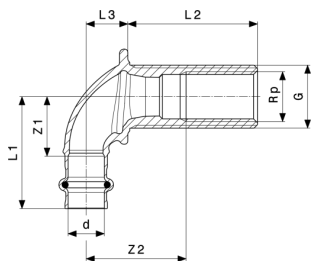

Sanpress-Wanddurchführung
- Rotguss oder Siliziumbronze
Modell 2232.1

Artikel	d	Rp	G	L	Z1	Z2	L1	L2	L3
279 301	15	1/2	3/4	25	25	27	47	25	18
279 318	15	1/2	3/4	35	25	22	47	35	18
279 288	15	1/2	3/4	55	25	42	47	55	18
279 295	15	1/2	3/4	65	25	52	47	65	18

Z = Z-Maß
L = Länge

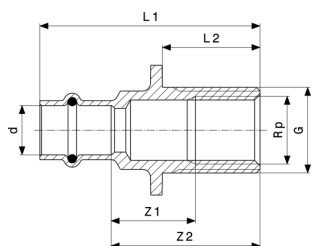

Sanpress-Wanddurchführung
- Rotguss oder Siliziumbronze
Modell 2232.3

Artikel	d	Rp	G	L	Z1	Z2	L1	L2
325 060	15	1/2	3/4	30	26	46	68	31

Z = Z-Maß
L = Länge

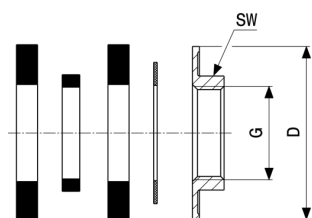

Montageset
Modell 1526.414-897

Artikel	G	SW	D
104 887	3/4	29	49

SW = Schlüsselweite
D = Außendurchmesser

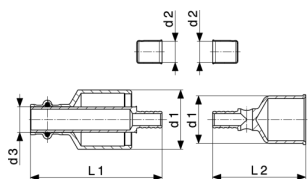

Smartloop-Anschlussset
- Rotguss oder Siliziumbronze
Modell 2276.1

Artikel	d1	d2	d3	L1	L2
632 229	28/35	12	15	78	55
470 289	28	12	15	78	55
470 272	35	12	15	78	59

L = Länge

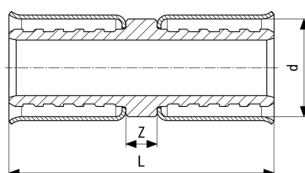

Smartloop-Kupplung
Modell 2276.8

Artikel	für d	Z	L
643 188	12	4	34

Z = Z-Maß
L = Länge

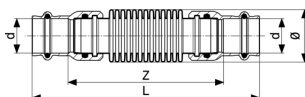

Kompensator
Modell 2251

Artikel	d	Z	L	Ø
690 250	15	100	144	25
690 267	18	104	148	27
690 274	22	102	149	34
690 281	28	121	168	41
690 298	35	123	174	50
690 304	42	127	199	60
690 311	54	137	217	72

Z = Z-Maß
L = Länge

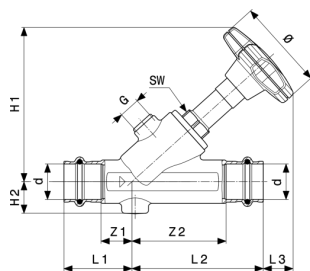

Easytop-Schrägsitzventil Modell 2237.5

Artikel	DN	d	Z1	Z2	L1	L2	L3	H1	H2	Ø
756 864	15	15	15	46	37	68	19	84	16	60
756 871	15	18	15	46	37	68	19	84	18	60
756 888	20	22	20	60	43	83	17	96	20	60
756 895	25	28	23	66	46	89	31	115	23	73
756 901	32	35	25	80	50	105	32	131	27	73
756 918	40	42	29	84	65	120	41	154	31	98
756 925	50	54	30	105	70	145	43	178	37	98

Artikel	DN	d	G	SW
756 864	15	15	¼	19
756 871	15	18	¼	19
756 888	20	22	¼	19
756 895	25	28	¼	27
756 901	32	35	¼	27
756 918	40	42	¼	39
756 925	50	54	¼	32

Z = Z-Maß

L = Länge

H = Höhe

SW = Schlüsselweite

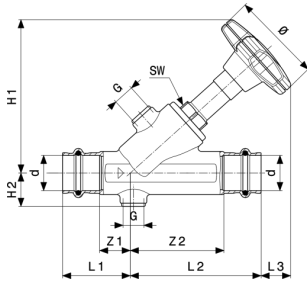

**Easytop-KRV-Schrägsitzventil
Modell 2238.5**

Artikel	DN	Z1	Z2	L1	L2	L3	H1	H2	Ø	G
757 199	15	15	46	37	68	20	85	17	60	¼
757 205	15	15	46	37	68	20	85	19	60	¼
757 212	20	20	60	43	83	17	96	21	60	¼
757 229	25	23	66	46	89	32	116	24	73	¼
757 236	32	25	80	50	105	33	131	28	73	¼
757 243	40	29	84	65	120	36	149	32	98	¼
757 250	50	30	105	70	145	35	171	38	98	¼

Artikel	DN	SW
757 199	15	19
757 205	15	19
757 212	20	19
757 229	25	27
757 236	32	27
757 243	40	32
757 250	50	32

Z = Z-Maß

L = Länge

H = Höhe

SW = Schlüsselweite

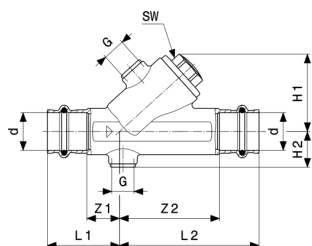

**Easytop-Rückflussverhinderer
Modell 2239.4**

Artikel	DN	d	Z1	Z2	L1	L2	H1	H2	G	SW
757 526	15	15	15	46	37	68	41	17	¼	19
757 533	15	18	15	46	37	68	41	19	¼	19
757 540	20	22	20	60	43	83	46	21	¼	19
757 557	25	28	23	66	46	89	59	24	¼	27
757 564	32	35	25	80	50	105	67	28	¼	27
757 571	40	42	29	84	65	120	78	32	¼	32
757 588	50	54	30	105	70	145	90	38	¼	32

Z = Z-Maß
L = Länge
H = Höhe
SW = Schlüsselweite

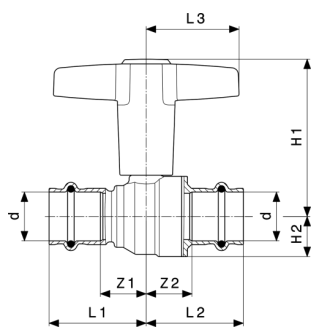

**Easytop-Kugelhahn
Modell 2275**

Artikel	DN	d	Z1	Z2	L1	L2	L3	H1	H2
746 377	15	15	20	20	42	42	43	69	15
746 384	15	18	20	20	42	42	43	69	15
746 391	20	22	21	20	45	43	43	72	18
746 407	25	28	26	26	49	50	51	91	22
746 414	32	35	34	27	59	52	51	97	28
746 421	40	42	37	32	73	68	60	119	34
746 438	50	54	44	38	84	78	60	127	41

Z = Z-Maß
L = Länge
H = Höhe

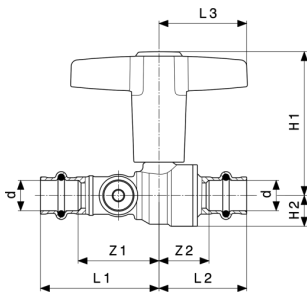
**Easytop-Kugelhahn
Modell 2275.3**

Artikel	DN	d	Z1	Z2	L1	L2	L3	H1	H2
746 681	15	15	35	20	57	42	43	69	15
746 698	15	18	34	20	56	42	43	69	15
746 704	20	22	38	20	62	43	43	72	18
746 711	25	28	43	26	66	50	51	91	22
746 728	32	35	57	27	82	52	51	97	28
746 735	40	42	62	32	98	68	60	119	34
746 742	50	54	70	38	110	78	60	127	42

Z = Z-Maß
L = Länge
H = Höhe

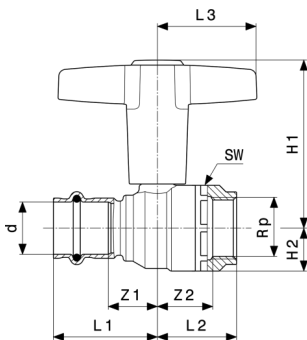
**Easytop-Kugelhahn
Modell 2275.4**

Artikel	DN	d	Rp	Z1	Z2	L1	L2	L3	H1	H2
746 759	15	15	½	20	24	42	33	43	69	15
746 766	15	18	½	20	24	42	33	43	15	15
746 773	20	22	¾	21	22	45	34	43	72	18
746 780	25	28	1	26	29	49	41	51	91	22
746 797	32	35	1¼	30	34	55	48	51	97	28
746 803	40	42	1½	37	39	73	52	60	119	34
746 810	50	54	2	44	45	84	62	60	127	42

Z = Z-Maß
L = Länge
H = Höhe
SW = Schlüsselweite

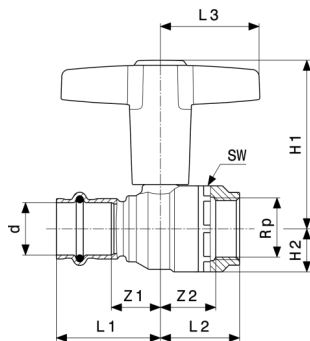

**Easytop-Kugelhahn
Modell 2275.4**

Artikel	DN	d	Rp	SW
746 759	15	15	½	28
746 766	15	18	½	28
746 773	20	22	¾	35
746 780	25	28	1	43
746 797	32	35	1¼	49
746 803	40	42	1½	57
746 810	50	54	2	70

Z = Z-Maß
L = Länge
H = Höhe
SW = Schlüsselweite

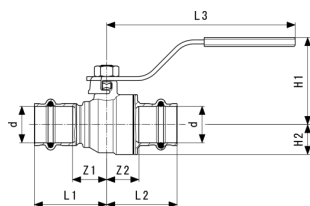

**Easytop-Kugelhahn
- Siliziumbronze
Modell 2275.10**

Artikel	Z1	Z2	L1	L2	L3	H1	H2
774 851	20	20	42	42	116	51	15
774 868	20	20	42	42	116	51	15
774 875	21	20	45	43	116	53	18
774 882	26	26	49	50	147	63	22
774 899	30	27	55	52	147	68	28
774 905	37	32	73	68	156	77	34
774 912	44	38	84	78	156	84	42

Z = Z-Maß
L = Länge
H = Höhe

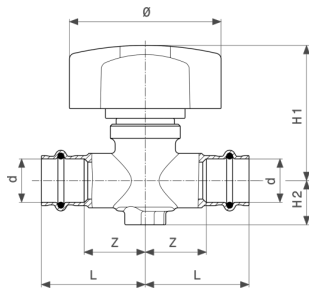

**Easytop-Freiflussventil
Modell 2278**

Artikel	d	Z	L	H1	H2	Ø
747 312	15	32	54	70	23	79
747 329	18	31	53	70	23	79
747 336	22	31	55	70	23	79

Z = Z-Maß

L = Länge

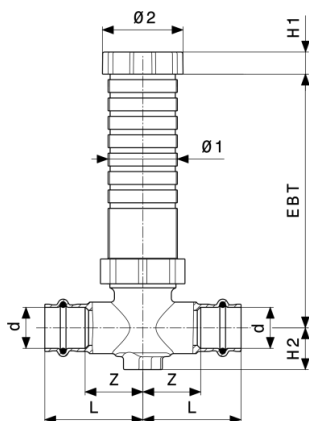
H = Höhe

**Easytop-UP-Freiflussventil
Modell 2278.5**

Artikel	d	EBT	Z	L	H1	H2	Ø1	Ø2
747 343	15	45-130	32	54	12	23	38	44
747 350	18	45-130	31	53	12	23	38	44
747 367	22	45-130	31	55	12	23	38	44

EBT = Einbautiefe

Z = Z-Maß

L = Länge

H = Höhe

Ø = Durchmesser

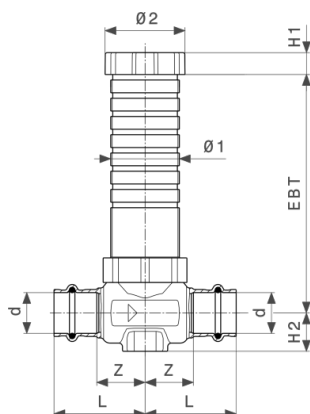

**Easytop-UP-Geradsitzventil
Modell 2235.2**

Artikel	DN	d	EBT	Z	L	H1	H2	Ø1	Ø2
755 591	15	15	45-130	28	50	12	21	38	44
755 607	15	18	45-130	28	50	12	21	38	44
755 614	20	22	45-130	27	50	12	21	38	44
755 621	25	28	45-130	27	50	12	21	38	44

EBT = Einbautiefe

Z = Z-Maß

L = Länge

H = Höhe

Ø = Durchmesser

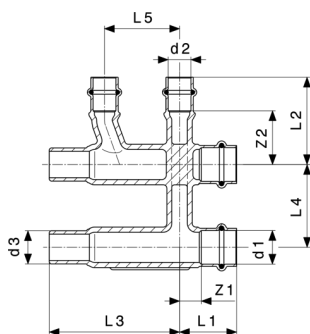

**Sanpress-Estrichverteiler
- Rotguss
Modell 2252**

Artikel	d1	d2	d3	Z1	Z2	L1	L2	L3	L4	L5
364 298 ¹⁾	22	10	22	15	33	38	50	87	55	50
397 166	22	15	22	15	36	38	58	87	55	50

Z = Z-Maß

L = Länge

¹⁾ Pressverbindung d10 ist mit einer 12er-Pressbacke auszuführen.

* = Lieferung nur noch aus Lagervorrat

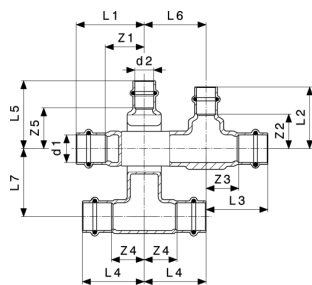

Sanpress-Kreuzungs-T-Stück
- Rotguss
Modell 2249.3

Artikel	d1	d2	Z1	Z2	Z3	Z4	Z5	L1	L2	L3
493 325	15	15	33	28	28	28	33	55	50	50
493 332	18	15	33	28	28	28	33	55	50	50
493 356	22	15	32	28	27	27	33	55	50	50
493 349	22	18	32	28	27	27	33	55	50	50

Artikel	d1	d2	L4	L5	L6	L7
493 325	15	15	50	55	50	55
493 332	18	15	50	55	50	55
493 356	22	15	50	55	50	55
493 349	22	18	50	55	50	55

Z = Z-Maß
L = Länge

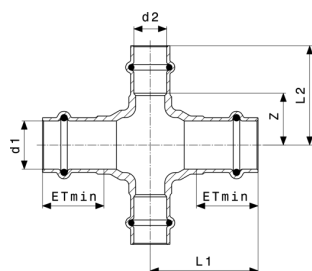

Sanpress-Kreuzungsstück
- Rotguss oder Siliziumbronze
Modell 2244

Artikel	d1	d2	ETmin	Z	L1	L2
424 435*	15	15	22	20	50	42
424 473*	18	15	22	21	50	43
424 497	22	15	24	24	50	46

ETmin = Einstecktiefe minimal

Z = Z-Maß

L = Länge

* = Lieferung nur noch aus Lagervorrat

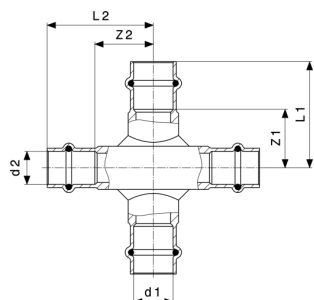

Sanpress-Kreuzstück
- Rotguss
Modell 2248

Artikel	d1	d2	Z1	Z2	L1	L2
322 410	15	15	26	26	48	48
322 427	18	15	27	27	49	49
323 370	22	15	27	30	50	52
323 363	28	15	31	33	54	55

Z = Z-Maß
L = Länge

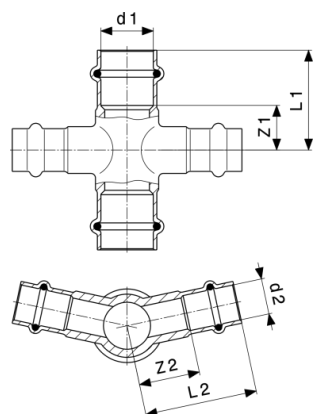

Sanpress-Kreuzstück 24°
- Rotguss
Modell 2247

Artikel	d1	d2	Z1	Z2	L1	L2
325 985	18	15	21	24	42	46
325 978	22	15	19	21	43	48

Z = Z-Maß
L = Länge

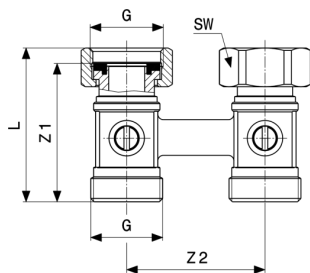

Heizkörperanschlussstück
- Messing matt-vernickelt
Modell 1096.5

Artikel	G	Stichmaß	Z1	L	SW
359 102	3/4	50	48	54	30

Z = Z-Maß
L = Länge
SW = Schlüsselweite

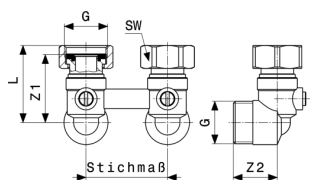

Heizkörperanschlussstück
- Messing matt-vernickelt
Modell 1097.5

Artikel	G	Stichmaß	Z1	Z2	L	SW
359 133	3/4	50	42	27	47	30

Z = Z-Maß
L = Länge
SW = Schlüsselweite

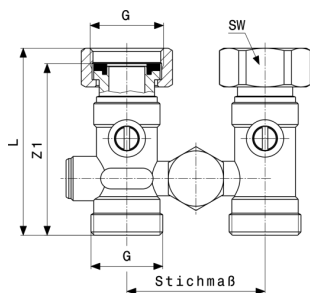

Heizkörperanschlussstück
- Messing matt-vernickelt
Modell 1096.0

Artikel	G	Stichmaß	Z1	L	SW
359 096	3/4	50	62	68	30

Z = Z-Maß
L = Länge
SW = Schlüsselweite

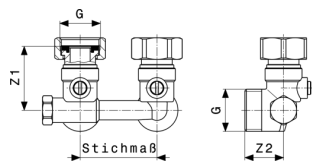

Heizkörperanschlussstück
- Messing matt-vernickelt
Modell 1097.0

Artikel	G	Stichmaß	Z1	Z2	L	SW
359 126	¾	50	43	25	47	30

Z = Z-Maß
L = Länge
SW = Schlüsselweite

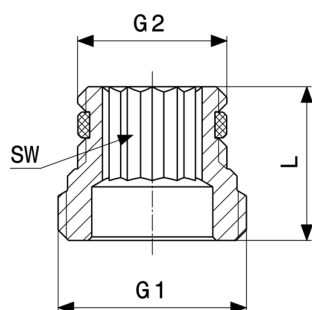

Adapterset
- Messing
Modell 1096.8

Artikel	G1	G2	L	SW
357 122	½	¾	22	12

L = Länge
SW = Schlüsselweite

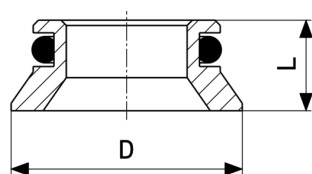

Adapterset
Modell 1096.9

Artikel	D	L
308 872	22	9

D = Außendurchmesser
L = Länge

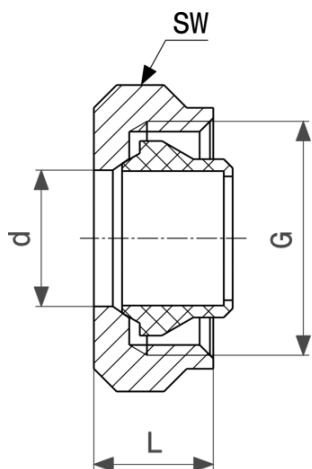

Anschlussverschraubung
 - Messing vernickelt
Modell 94385.1

Artikel	d	G	L	SW
112 608	12	¾	14	30
105 358	15	¾	14	30

L = Länge
 SW = Schlüsselweite

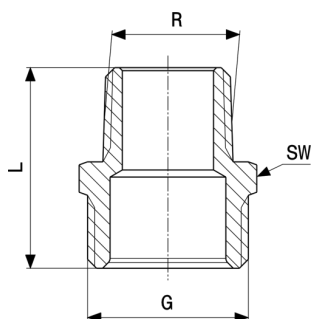

Adapterset
 - Messing matt-vernickelt
Modell 1022.6

Artikel	R	G	L	SW
153 687	½	¾	33	27

L = Länge
 SW = Schlüsselweite

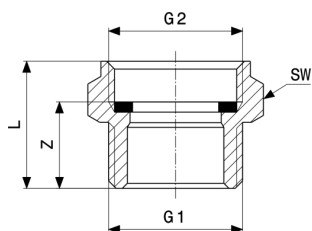

Adapterset
- Messing matt-vernickelt
Modell 1022.5

Artikel	G1	G2	Z	L	SW
137 342	¾	¾	17	25	30

Z = Z-Maß
L = Länge
SW = Schlüsselweite

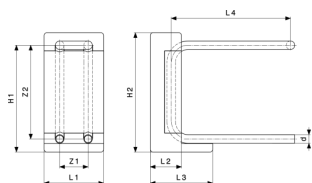

Heizkörperanschlussblock
Modell 1097.6

Artikel	d	Z1	Z2	L1	L2	L3	L4	H1	H2
364 045	15	50	165	105	55	110	210	188	210
379 698	15	50	235	105	55	110	210	258	280

Z = Z-Maß
L = Länge
H = Höhe

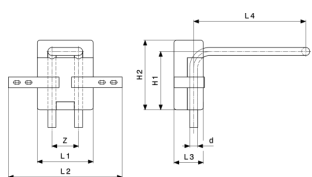

Heizkörperanschlussblock
Modell 1097.9

Artikel	d	H	Z	L1	L2	L3	L4	H1	H2
586 379	15	150	50	105	214	55	210	109	130

Z = Z-Maß
L = Länge
H = Höhe

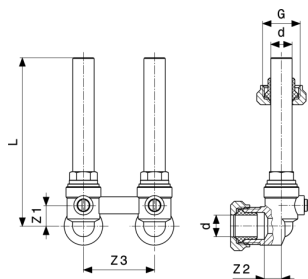

Heizkörperanschlusset
- Messing matt-vernickelt
Modell 1097.7

Artikel	d	G	Z1	Z2	Z3	L
364 052	15	¾	15	11	50	118

Z = Z-Maß
L = Länge

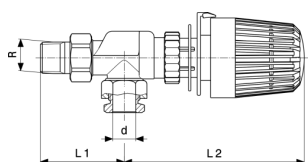

Heizkörperaxialventil
- Messing vernickelt
Modell 1075.96

Artikel	d	R	L1	L2
360 405	15	½	56	120

L = Länge

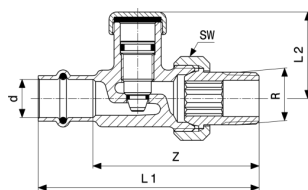

Sanpress-Rücklaufverschraubung
- Rotguss
Modell 2272.2

Artikel	d	R	Z	L1	L2	SW
326 364	15	½	67	89	35	29

Z = Z-Maß
L = Länge
SW = Schlüsselweite

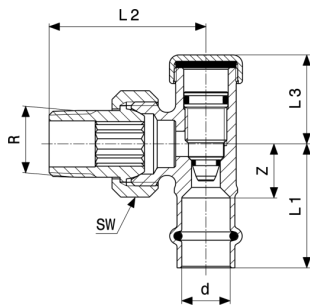

Sanpress-Rücklaufverschraubung
- Rotguss
Modell 2272.1

Artikel	d	R	Z	L1	L2	L3	SW
326 357	15	½	17	39	50	28	29

Z = Z-Maß
L = Länge
SW = Schlüsselweite

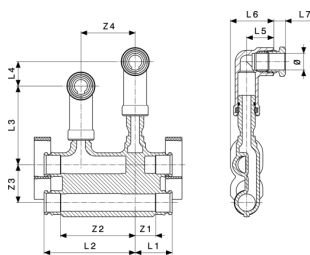

Sockelleisten-Heizkörperanschlussstück
- Rotguss
Modell 2277.2

Artikel	∅	Z1	Z2	Z3	Z4	L1	L2	L3	L4	L5
662 509	15	19	69	35	50	34	84	73	23	25

Artikel	∅	L6	L7
662 509	15	40	11

Z = Z-Maß
L = Länge

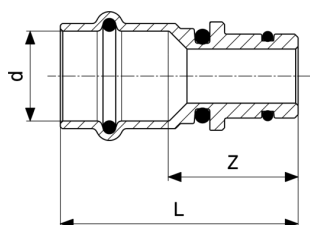

Sanpress-Steckadapter
- Rotguss
Modell 2233.5

Artikel	d	Z	L
662 516	15	25	47
662 523	18	27	49

Z = Z-Maß
L = Länge

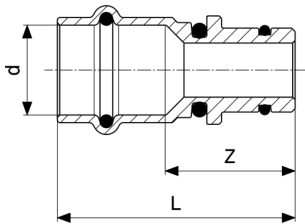

Sanpress-Steckadapter
- Rotguss
Modell 2233.5

Artikel	d	Z	L
662 530	22	29	52

Z = Z-Maß
L = Länge

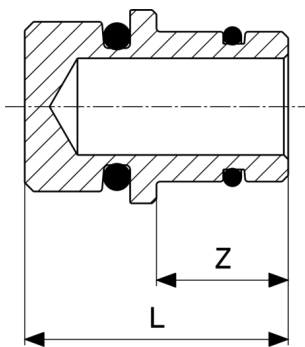

Steckadapter
- Rotguss oder Siliziumbronze
Modell 2233.6

Artikel	Z	L
663 346	15	30

Z = Z-Maß
L = Länge

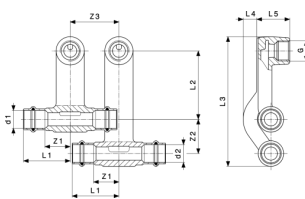

Sanpress-Heizkörperanschlussstück
- Rotguss
Modell 2273.1

Artikel	d1	G	d2	Z1	Z2	Z3	L1	L2	L3	L4
446 628	15	½	15	26	35	50	48	70	131	14
446 635	18	½	18	26	35	50	48	70	131	14

Artikel	d1	G	d2	L5
446 628	15	½	15	34
446 635	18	½	18	31

Z = Z-Maß
L = Länge

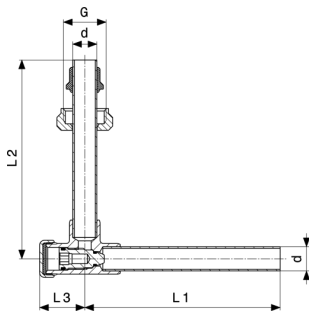

Heizkörperanschlussset
- Messing vernickelt
Modell 2272.5

Artikel	d	G	L1	L2	L3
360 399	15	3/4	121	123	28

L = Länge

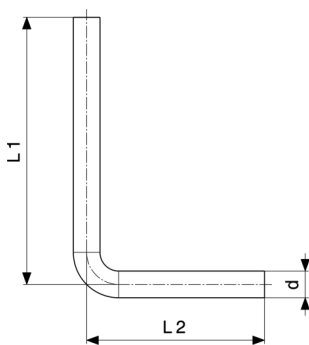

Anschlussbogen 90°
- Edelstahl
Modell 2271.1

Artikel	d	L1	L2
449 292	15	150	100
366 056	15	350	100

L = Länge

Impressum

Viega GmbH

Raiffeisenplatz 1, Top 4a

A-4863 Seewalchen

info@viega.at

(07662) 29880-0

(07662) 29880-30

UST-IdNr. ATU65008001

Gesellschaft mit beschränkter Haftung

Firmenbuch FN 328215 w

Geschäftsführer:

Diplom Ökonom Dirk Gellisch

Bei dem Submittal Package handelt es sich um unverbindliche Informationen, die Ihnen zur Verfügung gestellt werden. Alle Inhalte dieses Submittal Package werden mit großer Sorgfalt zusammengestellt. Dennoch können wir die Aktualität, Richtigkeit und Vollständigkeit der Informationen nicht gewährleisten. Das Submittal Package wird bei einer Bestellung nicht Vertragsbestandteil.