

Megapress Stainless 316
Submittal Package



table of contents

1	Product group description	3
2	Certificates	5
3	Z dimensions	6
4	Imprint	7

Product group description

Press connector made of stainless steel 1.4404 (316L). Press connectors with stainless steel cutting ring to ensure the mechanical strength of the connection. Suitable for concealed and pre-wall installations of riser pipes and floor installations.

Marking

Manufacturer, pipe dimension, batch, green dot on press end, green detachable label as press indicator

Press connector with SC-Contur

Inadvertently unpressed connections are noticed immediately during a leakage test.

Viega guarantees the detection of unpressed connections in the following pressure ranges with water, compressed air or inert gases:

Min. water pressure: 0.1 MPa / 100 kPa / 1 bar / 14.5 PSI

Max. water pressure: 0.65 MPa / 650 kPa / 6.5 bar / 94.3 PSI

Min. air pressure: 22 hPa / 2.2 kPa / 22 mbar / 0.3 PSI

Max. air pressure: 0.3 MPa / 300 kPa / 3 bar / 43.5 PSI

Sealing elements

EPDM (ethylene propylene diene rubber), black, pre-assembled

Notice

The sealing materials of the press connector system are subject to thermal ageing, which depends on the media temperature and the operating time.

The higher the media temperature, the faster the thermal ageing of the sealing material progresses.

In the case of special operating conditions, e.g. industrial heat recovery systems, it is necessary to compare the specifications of the appliance manufacturer with the specifications of the press connector system.

Before using the press connector system beyond the areas of application described or if in doubt about the correct selection of material, please contact Viega.

Dimensions

D $\frac{1}{2}$ –4, size availability in accordance with the national regulations

Tools

The functional safety of Viega press connector systems depends primarily on the faultless condition of the press tools used. Viega recommends the use of Viega press tools for pressing Viega press connectors. The Pressgun Press Booster is required for pressing Megapress Stainless 316 XL press connectors. Viega press tools have to be regularly maintained by authorised service partners.

Areas of application

Industrial and plant engineering

Cooling and heating systems

Compressed air systems

Rainwater

Agriculture

Systems for technical gases (request required)

Note

When used for other areas of use and when in doubt about the right selection of material, please contact Viega. The system components should be protected against high concentrations of chloride generated by both the medium and by external factors. Detailed information about applications, restrictions and national standards and directives can be found in the product information, either printed or on the Viega website.

Note – Standards and approvals

Suitable for stainless steel pipes(1.4541/1.4550/1.4571) according to DIN EN 10216-5 and DIN EN 10217-7. For use in heating systems, observe VDI Regulation 2035 and DIN EN 12828.

Operating conditions

The press connector system Megapress Stainless 316 can be used with the following operating parameters:
Heating systems in accordance with DIN EN 12828
Operating temperature max. 105 °C / 221 °F

The press connector system Megapress Stainless 316 is designed for nominal pressure PN 16.

Press connector material

Stainless steel 1.4404 (316L)

Subject to change without prior notice!

Latest Z- and installation dimensions as well as further technical information can be found on the Viega website and have to be checked before purchase, planning, construction work and use. Our products are continuously optimised.

This product description contains important information on choice of product and system, mounting, commissioning as well as intended use and, if required, on maintenance measures. This information on products, their features and application techniques is based on currently valid standards in Europe (e.g. EN) and/or in Germany (e.g. DIN/DVGW). Some passages in the text may refer to technical regulations in Europe/Germany. These should be considered as recommendations for other countries where no corresponding national requirements exist. The relevant national laws, standards, regulations, directives and other technical provisions take priority over the German/European directives specified in this product description: The information herein is not binding for other countries and regions and should be understood as recommendation.

Certificates

 The logo for Vd TÜV, featuring the letters "Vd" above "TÜV" inside a circular graphic.	<p>TÜV Association Certificate Megapress stainless 316 (1/2" - 4")</p>
--	---

Z dimensions

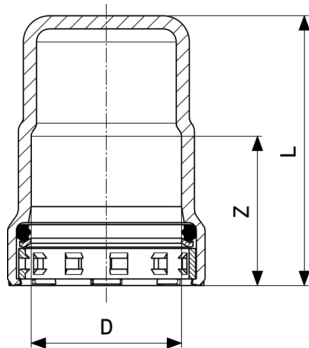

Megapress Stainless 316 Cap
- non-corroding steel
Model 6256

Article	DN	D	Z	L
804 336 ¹	15	½	28	55
804 343 ¹	20	¾	30	58
804 558 ¹	25	1	35	62
804 565 ¹	32	1¼	47	75
804 572 ¹	40	1½	49	77
804 589 ¹	50	2	51	79

¹⁾ without DVGW test mark

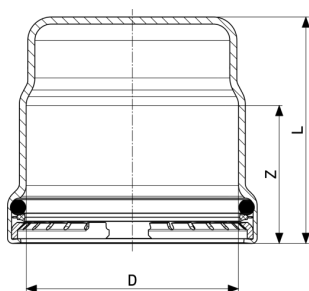

Megapress Stainless 316 XL Cap
- non-corroding steel
Model 6256.1XL

Article	DN	D	Z	L
804 596 ¹	65	2½	46	85
804 602 ¹	80	3	59	96
804 619 ¹	100	4	81	118

¹⁾ without DVGW test mark

Imprint

Viega GmbH & Co. KG

Viega Platz 1

57439 Attendorn

Germany

Phone: +49/2722/61-0

Fax: +49/2722/61-1566

The Viega GmbH & Co. KG is represented by the general partners: Viega Management B.V. (Managing directors: Michael Klenz, Sebastian Leigemann) and Viega Management GmbH (Managing directors: Michael Klenz, Sebastian Leigemann)

The Submittal Package contains non-binding information that is being provided to you. All contents in the Submittal Package have been compiled with the greatest possible care and attention. Despite this, we are unable to guarantee that the information is up to date, accurate and complete. Placing an order does not automatically render the Submittal Package part of the contract.