

Sanpress Inox

Submittal Package



table of contents

1	Product group description	3
2	Permitted pipes	5
3	Certificates	6
4	Z dimensions	10
5	Imprint	21

Product group description

Flow-optimised press connector system with press connectors made of stainless steel 1.4401 and pipes from stainless steel 1.4401 and 1.4521. Press connectors for protecting the sealing element equipped with cylindrical pipe guide. Press connectors from d64.0 with stainless steel cutting ring to ensure the mechanical strength of the connection. For protection pipes are equipped with pipe plugs. The pressing force is located before and behind the sealing element seat. Suitable for concealed and pre-wall installations of riser pipes and floor installations.

Marking

Manufacturer, pipe dimension, batch, green dot on press end, yellow pipe plug for 1.4401, green pipe plug for 1.4521, detachable orange label as press indicator from d64.0

Press connector with SC-Contur

Inadvertently unpressed connections become visibly leaky when the system is filled.

Viega guarantees the detection of unpressed connections in the following pressure ranges:

min. water pressure: 0.1 MPa / 100 kPa / 1 bar / 14.5 PSI

max. water pressure: 0.65 MPa / 650 kPa / 6.5 bar / 94.3 PSI

min. air pressure: 22 hPa / 2.2 kPa / 22 mbar / 0.3 PSI

max. air pressure: 0.3 MPa / 300 kPa / 3 bar / 43.5 PSI

Sealing elements

EPDM (ethylene propylene diene rubber), black, pre-assembled

Note

The sealing materials of the press connector system are subject to thermal ageing, which depends on the media temperature and the operating time.

The higher the media temperature, the faster the thermal ageing of the sealing material progresses.

In the case of special operating conditions, e.g. industrial heat recovery systems, it is necessary to compare the specifications of the appliance manufacturer with the specifications of the press connector system.

Before using the press connector system beyond the areas of application described or if in doubt about the correct selection of material, please contact Viega.

Dimensions

d15–108.0

Tools

The functional safety of Viega press connector systems depends primarily on the faultless condition of the press tools used. Viega recommends the use of Viega press tools for pressing Viega press connectors. Viega press tools have to be regularly maintained by authorised service partners.

Areas of application

Potable water

Heating/radiator connection

Rainwater

Compressed air systems

Agriculture

Industrial applications

Note

The press connector system Sanpress Inox is suitable for the creation of potable water installations according to DIN 1988-200 and EN 806-2 in consideration of the selection of material in accordance with DIN EN 12502-1 and according to the evaluation basis for metallic materials in contact with potable water of the Umweltbundesamt (UBA) (German Federal Environment Agency). When used for other areas of use and when in doubt about the right selection of material, please contact Viega. The system components should be protected against high concentrations of chloride generated by both the medium and by external factors. Detailed information about applications, restrictions and national standards and directives can be found in the product information, either printed or on the Viega website.

Note – Standards and approvals

Press connector system with press connectors and pipes in accordance with DIN EN 10088, DIN EN 10312, DVGW Worksheet GW 541 and W 534.

Pipe approval for 1.4521 (d12–108.0) according to DW-7301BS0375.

Pipe approval for 1.4401 (d12–108.0) according to DV -7301BS0411.

System approval for 1.4401 (d15–108.0) in accordance with DW-8501BL0551.

System approval for 1.4521 (d15–108.0) in accordance with DW-8501BS0376.

For use in heating systems, observe VDI Regulation 2035 and DIN EN 12828.

Special applications

Shipbuilding

Fire extinguishing systems

Operating conditions

The press connector system Sanpress Inox can be used with the following operating parameters:

potable water installation according to DIN 1988-200 / DIN EN 806-2

operating temperature max. 80 °C / 176 °F

temperature max. 95°C over a period of 60 min.

heating systems in accordance with DIN EN 12828

operating temperature max. 105 °C / 221 °F

The press connector system Sanpress Inox is designed for nominal pressure PN 16.

Stainless steel 1.4401

Subject to change without prior notice!









Latest Z- and installation dimensions as well as further technical information can be found on the Viega website and have to be checked before purchase, planning, construction work and use. Our products are continuously optimised.









This product description contains important information on choice of product and system, mounting, commissioning as well as intended use and, if required, on maintenance measures. This information on products, their features and application techniques is based on currently valid standards in Europe (e.g. EN) and/or in Germany (e.g. DIN/DVGW). Some passages in the text may refer to technical regulations in Europe/Germany. These should be considered as recommendations for other countries where no corresponding national requirements exist. The relevant national laws, standards, regulations, directives and other technical provisions take priority over the German/European directives specified in this product description: The information herein is not binding for other countries and regions and should be understood as recommendation.









Permitted pipes







pipe material	Model	Article	external Ø	wall thickness
stainless steel 1.4521	2205	615 987	12	1.0
stainless steel 1.4521	2205	615 994	15	1.0
stainless steel 1.4521	2205	616 007	18	1.0
stainless steel 1.4521	2205	616 014	22	1.2
stainless steel 1.4521	2205	616 021	28	1.2
stainless steel 1.4521	2205	616 038	35	1.5
stainless steel 1.4521	2205	616 045	42	1.5
stainless steel 1.4521	2205	616 557	54	1.5
stainless steel 1.4401	2203	297 824	12	1.0
stainless steel 1.4401	2203	102 036	15	1.0
stainless steel 1.4401	2203	289 034	18	1.0
stainless steel 1.4401	2203	102 708	22	1.2
stainless steel 1.4401	2203	104 924	28	1.2
stainless steel 1.4401	2203	108 588	35	1.5
stainless steel 1.4401	2203	113 001	42	1.5
stainless steel 1.4401	2203	193 676	54	1.5
stainless steel 1.4401	2203XL	578 626	64.0	2.0
stainless steel 1.4401	2203XL	354 862	76.1	2.0
stainless steel 1.4401	2203XL	354 855	88.9	2.0
stainless steel 1.4401	2203XL	354 848	108.0	2.0
stainless steel 1.4521	2205XL	616 564	64.0	2.0
stainless steel 1.4521	2205XL	616 571	76.1	2.0
stainless steel 1.4521	2205XL	616 588	88.9	2.0
stainless steel 1.4521	2205XL	616 595	108.0	2.0

Certificates

Dubai	Dubai Central Laboratory Department Attestation of Conformity Sanpress Inox fittings
	ÖVGW certificate Sanpress Inox (d 15 - 108)
	ÜA sign Raxinox pipes
	ÜA sign Sanpress Inox fittings, Raxinox fittings
	SAI Watermark Certificate of Conformity - Level 1 Propress Water, Sanpress and Sanpress Inox
	SAI Watermark Certificate of Conformity 316 Inox Tube
	SAI Certificate of Conformity 372:2020
	BCCA Certificate ATG Profipress, Sanpress, Sanpress Inox
	CCS Certificate of Type Approval Sanpress Inox, Seapress, Profipress
SZU	SZU Certificate Sanpress Inox, Sanpress Inox LF
SZU	SZU Buildig Technical Certificate. Sanpress Inox, Sanpress Inox LF
AMTEC	AMTEC Certificate Profipress, Sanpress, Sanpress Inox, Prestabo, Megapress, Profipress G, Sanpress Inox G, Megapress G

DEKRA	examination certificate Rohrleitungssystem SP Inox / Inox XL
	DVGW type examination certificate Sanpress-pipe 1.4521 (d 12 - 108)
	DVGW type examination certificate Sanpress Inox with pipe 1.4401 (d 15 - 108)
	DVGW type examination certificate Sanpress Inox with pipe 1.4521 (d 15 - 108)
	DVGW type examination certificate Sanpress pipe 1.4401 (d 12 - 108)
	TÜV Association Certificate Profipress, Sanpress, Sanpress Inox, Prestabo (d 15 - 108), Temponox
	VdS certificate Sanpress Inox with pipe 1.4401 and 1.4521 (d 15 - 108)
	CSTB Certificate Sanpress Inox with pipe 1.4401 and 1.4521, (d 15-108)
	CSTB QB Certificate Sanpress Inox with pipe 1.4401 et 1.4521
Eurofins	Eurofins Certificate of sanitary conformity Sanpress Inox
BSI	BSI Kitemark Certificate Sanpress Inox, Sanpress Inox G

	<p>Lloyd's Register Type Approval Certificate Sanpress Inox, ProPress 304 FKM, ProPress 316</p>
<p>EMI</p>	<p>EMI certificate Profipress, Sanpress, Easytop, Sanpress Inox, Pexfit Pro Fosta, Smartpress, gunmetal threaded fittings</p>
<p>EMI</p>	<p>EMI Certificate of Constancy of Performance Sanpress Inox</p>
	<p>IAPMO UPC-I Certificate of Listing Sanpress Inox</p>
	<p>IAPMO UMC- I Certificate of Listing Sanpress Inox</p>
	<p>IRS Type Approval Certificate Seapress, Sanpress, Sanpress Inox, Profipress</p>
	<p>ICIM Hygiene certificate Profipress, Profipress XL, Sanpress Inox, Sanpress Inox XL, Sanpress, Sanpress XL, Sanfix Fosta, Raxofix, Smartpress, gunmetal threaded fittings, soldered fittings</p>
	<p>RINA Type Approval Certificate Sanpress Inox / Sanpress Inox XL</p>
	<p>Class NK Type Approval Certificate Seapress, Seapress XL, Profipress and Sanpress Inox</p>
	<p>KIWA Product certificate Sanpress Inox fittings</p>
	<p>KIWA Product certificate PE-Xc Smartloop pipe</p>
<p>SINTEF</p>	<p>SINTEF Certificate Sanpress Inox med rustfrie stalror 1.4401 og 1.4521 (d 15-108)</p>

SINTEF	SINTEF Certificate Smartloop
	ITB National Technical Assessment Sanpress Inox, Sanpress Inox XL, Sanpress, Sanpress XL
	ITB National Technical Assessment Sanpress Inox
	ITB Certificate of Constancy of Performance Sanpress Inox
EITS	EITS Technical Approval Sanpress, Sanpress Inox
	RM Type Approval Certificate Sanpress Inox and Sanpress Inox XL
	RISE Certificate Smartloop
IZV	IZV Certificate Sanpress Inox, Sanpress Inox XL
UKRCERTIFICATION	LLC UKRCertification Certificate of conformity Sanpress, Sanpress Inox
	ABS Approval Certificate Viega Imperial CTS system ProPress 316, ProPress 304 FKM and Viega Metric CTS system Sanpress Inox and Sanpress Inox XL

Z dimensions

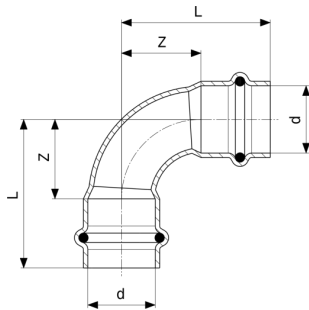

Sanpress Inox Elbow 90°
- non-corroding steel
Model 2316

Article	d	Z	L	Z*	L*
435 639	15	16	38	26	48
435 646	18	18	40	36	58
435 653	22	26	49	44	67
435 660	28	34	58	48	72
435 677	35	33	59	60	86
435 684	42	50	87	71	107
435 691	54	65	105	92	132

Z* = predecessor

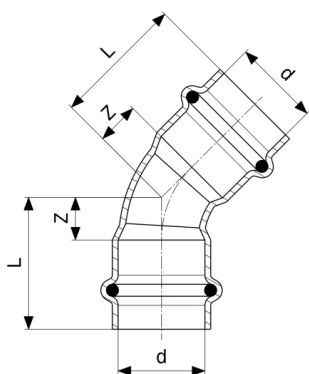

Sanpress Inox Elbow 45°
- non-corroding steel
Model 2326

Article	d	Z	L	Z*	L*
435 776	15	7	29	13	35
435 783	18	7	29	18	40
435 790	22	11	34	22	45
435 806	28	14	38	21	45
435 813	35	15	41	28	54
435 363	42	21	57	33	69

Z* = predecessor

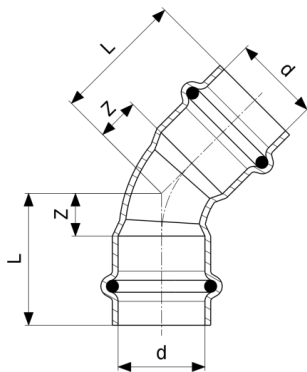

Sanpress Inox Elbow 45°
- non-corroding steel
Model 2326

Article	d	Z	L	Z*	L*
435 370	54	27	67	44	84

Z* = predecessor

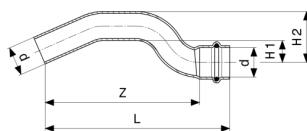

Sanpress Inox Crossover
- non-corroding steel
Model 2327

Article	VdS	d	Z	L	H1	H2
452 926		15	97	119	13	28
452 933		18	103	125	13	31
452 940	✓	22	123	146	15	37

VdS = VdS certification

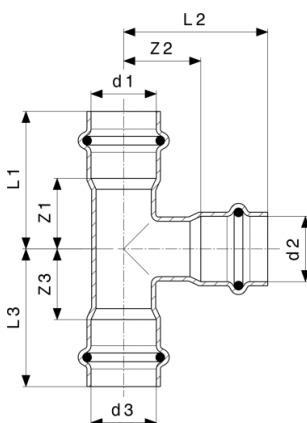

Sanpress Inox T-piece
- non-corroding steel
Model 2318

Article	d1	d2	d3	Z1	Z2	Z3	L1	L2	L3
435 851	15	15	15	19	22	19	41	44	41
452 469	18	15	15	32	22	19	54	44	41
435 929	18	15	18	21	23	21	43	45	43

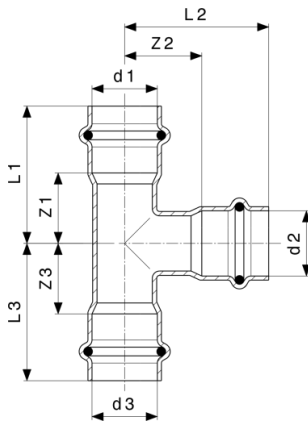

Sanpress Inox T-piece
- non-corroding steel
Model 2318

Article	d1	d2	d3	Z1	Z2	Z3	L1	L2	L3
435 868	18	18	18	21	23	21	43	45	43
435 936	22	15	22	22	25	22	45	47	45
435 943	22	18	22	22	25	22	45	47	45
435 875	22	22	22	24	27	24	47	50	47
435 950	28	15	28	21	29	21	45	51	45
435 967	28	18	28	21	29	21	45	51	45
452 506	28	22	22	23	31	41	47	54	64
435 974	28	22	28	23	31	23	47	54	47
435 882	28	28	28	28	29	28	52	53	52
435 981	35	15	35	19	33	19	45	55	45
435 998	35	18	35	19	33	19	45	55	45
436 001	35	22	35	21	34	21	47	57	47
436 018	35	28	35	27	33	27	53	57	53
435 899	35	35	35	27	27	27	53	53	53
436 025	42	18	42	19	36	19	55	58	55
436 032	42	22	42	19	38	19	55	61	55
436 049	42	28	42	25	37	25	61	61	61
435 837	42	35	42	25	30	25	61	56	61
435 905	42	42	42	32	32	32	68	68	68
435 844	54	22	54	18	44	18	58	67	58
436 056	54	28	54	21	43	21	61	67	61
436 063	54	35	54	25	36	25	65	62	65
436 070	54	42	54	29	38	29	69	74	69
435 912	54	54	54	39	39	39	79	79	79

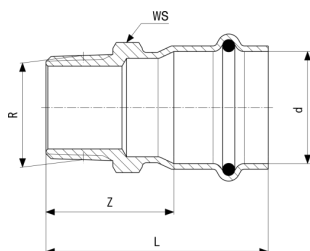

Sanpress Inox Adapter
- non-corroding steel
Model 2311

Article	d	R	Z	L	WS
436 445	15	1/2	31	53	22
436 452	15	3/4	34	56	27
436 469	18	1/2	30	52	22
436 476	18	3/4	33	55	27
436 483	22	1/2	31	54	24
436 490	22	3/4	33	56	27
436 506	22	1	34	57	34
436 513	28	3/4	32	57	30
436 520	28	1	33	57	34
436 537	35	1	34	60	36
436 544	35	1 1/4	43	69	46
436 551	42	1 1/2	45	81	50
436 568	54	2	59	89	62

WS = wrench size

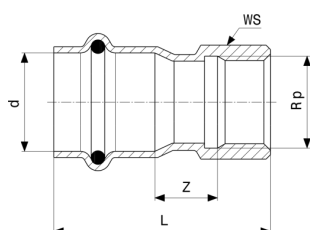

Sanpress Inox Adapter
- non-corroding steel
Model 2312

Article	d	Rp	Z	L	WS
436 575	15	1/2	17	49	24
436 582	15	3/4	17	50	30
436 599	18	1/2	17	48	24
436 605	18	3/4	16	49	30
436 612	22	1/2	16	49	24
436 629	22	3/4	16	50	30
436 636	22	1	18	53	36

WS = wrench size

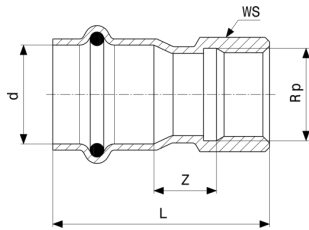

Sanpress Inox Adapter
- non-corroding steel
Model 2312

Article	d	Rp	Z	L	WS
436 643	28	¾	16	51	30
436 650	28	1	18	54	36
436 667	35	1¼	19	60	46
436 674	42	1½	21	73	55
436 681	54	2	24	83	65

WS = wrench size

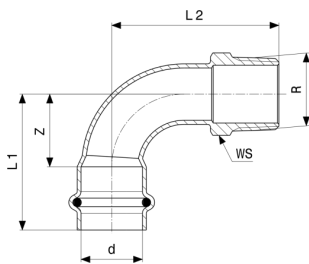

Sanpress Inox Adapter elbow 90°
- non-corroding steel
Model 2314

Article	d	R	Z	L1	L2	WS	Z*	L1*	L2*	WS*
436 896	15	½	16	38	44	22	26	38	41	22
436 902	18	½	18	40	46	22	30	52	43	22
436 919	18	¾	18	40	50	27	30	52	52	27
436 926	22	¾	26	49	61	27	37	60	61	27
436 933	28	1	34	58	77	36				
436 940	35	1¼	33	59	78	46	60	86	91	45
436 957	42	1½	50	87	102	50				
436 964	54	2	65	105	121	62				

WS = wrench size

Z* = predecessor

WS* = predecessor (wrench size)

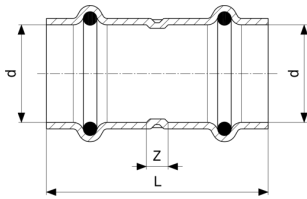

Sanpress Inox Coupling
- non-corroding steel
Model 2315

Article	d	Z	L
436 155	15	12	56
436 162	18	11	55
436 179	22	13	59
436 186	28	12	60
436 193	35	12	64
436 209	42	12	85
436 216	54	12	93

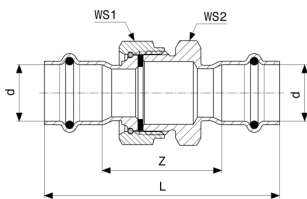

Sanpress Inox Screw fitting
- non-corroding steel
Model 2360

Article	VdS	d	Z	L	WS1	WS2
437 381		15	42	86	30	30
437 398		18	41	85	30	27
437 404	✓	22	48	94	37	36
437 411	✓	28	53	101	46	46
437 428	✓	35	58	111	53	50
437 435	✓	42	64	136	60	55
437 442	✓	54	71	152	78	70

VdS = VdS certification
WS = wrench size

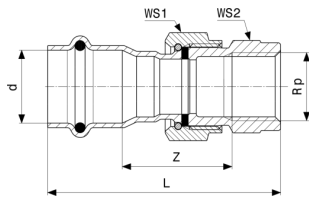

Sanpress Inox Adapter union
- non-corroding steel
Model 2362

Article	d	Rp	Z	L	WS1	WS2
437 459	15	½	29	66	30	27
437 466	15	¾	33	71	30	30
437 473	18	½	28	65	30	27
437 480	18	¾	32	71	30	30
437 497	22	½	34	72	30	27
437 503	22	¾	40	79	30	31
437 510	22	1	39	81	37	40
437 527	28	¾	46	87	37	34
437 534	28	1	47	90	37	40
437 541	35	1¼	36	83	53	50
437 558	42	1½	41	98	60	55
437 565	54	2	30	96	78	66

WS = wrench size

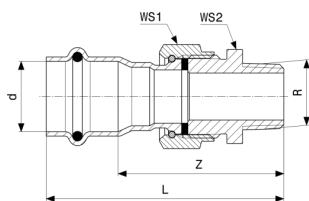

Sanpress Inox Adapter union
- non-corroding steel
Model 2365

Article	VdS	d	R	Z	L	WS1	WS2
438 258		15	½	46	68	30	27
438 265		15	¾	47	69	30	27
438 272		18	½	45	67	30	27
438 289		18	¾	47	69	30	27
438 296	✓	22	½	53	76	30	27
438 302	✓	22	¾	54	77	30	27
438 319	✓	22	1	54	77	37	34
438 326	✓	28	¾	60	84	37	34
438 333	✓	28	1	62	86	37	34

VdS = VdS certification
WS = wrench size

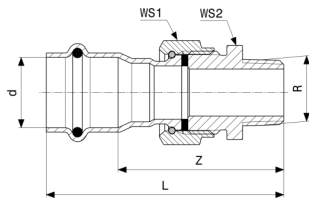

Sanpress Inox Adapter union
- non-corroding steel
Model 2365

Article	VdS	d	R	Z	L	WS1	WS2
438 340	✓	35	1¼	63	89	53	50
438 357	✓	42	1½	65	101	60	55
438 364	✓	54	2	78	118	78	72

VdS = VdS certification
WS = wrench size

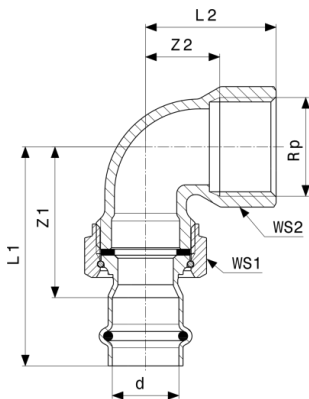

Sanpress Inox Adapter union 90°
- non-corroding steel
Model 2355

Article	d	Rp	Z1	Z2	L1	L2	WS1	WS2
437 299	15	½	41	18	63	33	30	25
437 305	18	½	41	18	63	33	30	25
437 312	18	¾	44	23	66	39	36	31
437 329	22	¾	48	23	71	39	37	31
437 336	22	1	51	25	74	44	37	38
437 343	28	1	57	28	81	47	46	38
437 350	35	1¼	60	35	86	57	53	46
437 367	42	1½	72	38	108	59	60	53
437 374	54	2	84	43	125	69	78	65

WS = wrench size

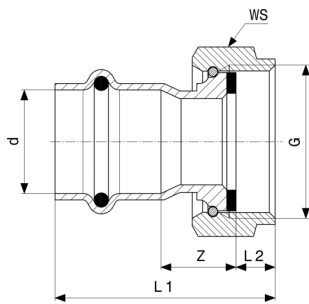

Sanpress Inox Connection screw fitting
- non-corroding steel
Model 2363

Article	VdS	d	G	Z	L1	L2	WS
437 572		15	½	21	50	7	24
437 589		15	¾	15	46	9	30
437 596		18	½	24	52	7	24
437 602		18	¾	15	45	8	30
437 619	✓	22	¾	22	54	8	30
437 626	✓	22	1	16	48	8	37
437 633	✓	28	1	24	56	8	37
437 640	✓	28	1¼	18	52	10	46
437 862	✓	35	1½	18	55	10	53
437 893	✓	42	1¾	22	69	11	60
437 923	✓	42	2	24	75	14	66
437 947	✓	54	2¾	24	77	13	78
437 992	✓	54	2½	25	81	16	84

VdS = VdS certification
WS = wrench size

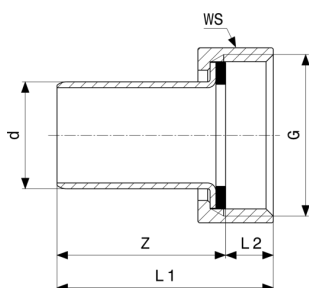

Sanpress Inox Connection screw fitting
- non-corroding steel
Model 2364

Article	d	G	Z	L1	L2	WS
438 180	15	¾	34	43	9	29
438 197	18	¾	34	43	9	29
438 203	22	1	35	45	10	36
438 210	28	1¼	36	47	11	46

WS = wrench size

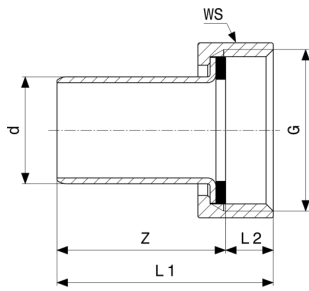

Sanpress Inox Connection screw fitting
- non-corroding steel
Model 2364

Article	d	G	Z	L1	L2	WS
438 227	35	1½	39	50	12	52
438 234	42	1¾	64	77	13	59
438 241	54	2¾	62	73	11	75

WS = wrench size

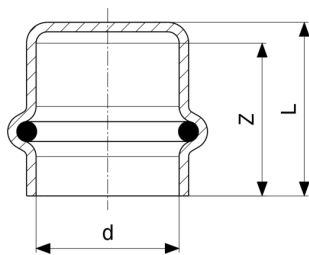

Sanpress Inox Cap
- non-corroding steel
Model 2356

Article	d	Z	L
452 858	15	23	26
452 865	18	23	26
452 872	22	24	27
452 889	28	25	28
452 896	35	27	31
452 902	42	36	41
452 919	54	40	44

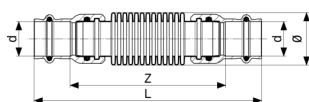

Compensator
Model 2251

Article	d	Z	L	[column name missing for ZM-000102]
690 250	15	100	144	25
690 267	18	104	148	27
690 274	22	102	149	34

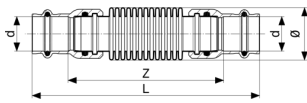

**Compensator
Model 2251**

Article	d	Z	L	[column name missing for ZM-000102]
690 281	28	121	168	41
690 298	35	123	174	50
690 304	42	127	199	60
690 311	54	137	217	72

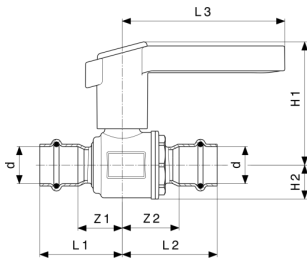

**Easytop Inox Ball valve
Model 2370**

Article	DN	d	Z1	Z2	L1	L2	L3	H1	H2
554 729	15	15	16	23	40	47	98	73	17
554 736	15	18	22	29	44	51	98	73	17
554 743	20	22	27	34	50	57	98	74	21
554 750	25	28	29	39	53	63	113	89	24
554 767	32	35	37	44	63	70	113	100	31
554 774	40	42	47	46	83	82	119	125	37
554 781	50	54	50	55	90	96	119	133	45

Imprint

Viega GmbH & Co. KG

Viega Platz 1

57439 Attendorn

Germany

Phone: +49/2722/61-0

Fax: +49/2722/61-1566

The Viega GmbH & Co. KG is represented by the general partners: Viega Management B.V. (Managing directors: Michael Klenz, Sebastian Leigemann) and Viega Management GmbH (Managing directors: Michael Klenz, Sebastian Leigemann)

The Submittal Package contains non-binding information that is being provided to you. All contents in the Submittal Package have been compiled with the greatest possible care and attention. Despite this, we are unable to guarantee that the information is up to date, accurate and complete. Placing an order does not automatically render the Submittal Package part of the contract.