

Viega Smartpress
submittal package



Inhoudsopgave

1	Productgroepenbeschrijving	3
2	Toegestane buizen	5
3	Certificaten	7
4	Z-maten	10
5	Impressie	40

Productgroepenbeschrijving

Voor stroming geoptimaliseerd persfittingsysteem met persfittings uit brons en roestvast staal en meerlagenbuizen. Meerlagenbuis, vormstabiel, zuurstofdicht, kleur: wit. Persfitting met PPSU-steunelement voor borging van de dichtheid en de mechanische belasting van de verbinding. Veilige en snelle verbinding zonder ruimen en kalibreren van de buiseinden door O-ringloze perstechnologie in alle leidingdiameters. Buizen zijn ter bescherming voorzien van buisstoppen. Geschikt voor opbouw- en inbouwinstallaties van stijgen en etageleidingen-installaties.

Meerlagenbuis

buitenkleur wit
geschikt voor drinkwater- en verwarmingsinstallaties

Meerlagenbuis

buitenkleur geel
geschikt voor aard- en vloeibaar gasinstallaties

Markering

Fabrikant, buismaat, charge, groene stip op persuiteinde, systeemtoelatingen

Persfittings met SC-Contur

Per ongeluk niet-geperste verbindingen worden duidelijk zichtbaar ondicht bij het vullen van de installatie.

Viega garandeert het herkennen van niet-geperste fittingen in de volgende drukbereiken:

min. waterdruk 0,1 MPa / 100 kPa / 1 bar / 14,5 PSI

max. waterdruk 0,65 MPa / 650 kPa / 6,5 bar / 94,3 PSI

min. luchtdruk: 22 hPa / 2,2Kpa / 22mbar / 0,3 PSI

max. luchtdruk: 0,3 MPa / 300 kPa / 43,5 PSI

Diameters

d16–63

Gereedschappen

De veilige werking van Viega persfittingsystemen hangt in eerste instantie af van de storingvrije toestand van de gebruikte persgereedschappen. Viega adviseert het gebruik van Viega persgereedschap voor het persen van Viega persfittings. Viega persgereedschap moet regelmatig worden onderhouden door geautoriseerde servicepartners.

Toepassingen

Drinkwater

Verwarmingsinstallaties

Aardgas/vloeibaar gas

Aanwijzing – normen en toelatingen

Buizen-toelating volgens KIWA K90277.

Persfittings-toelating volgens KIWA K21482.

Persfittings en buizen (d20–32) volgens KIWA Gastec K90466.

Aanwijzing

Het persfittingsysteem Viega Smartpress is geschikt voor de aanleg van drinkwaterinstallaties volgens NEN 1006 en EN 806-2, rekening houdend met de keuze van de materialen volgens NEN EN 12502-1 en volgens de metaalbeoordelingsbasis voor drinkwater (UBA). Als het voor andere toepassingen wordt gebruikt en u twijfelt over de juiste materiaalkeuze, neem dan contact op met Viega. Gedetailleerde informatie over gebruik, beperkingen en nationale normen en richtlijnen vindt u in de productinformatie, hetzij gedrukt of op de Viega website.

Bedrijfsvoorwaarden voor drinkwater-installaties

Bedrijfstemperatuur max. 70 °C / 158 °F
bedrijfsdruk max. 1,0 MPa / 10 bar / 145 PSI

Bedrijfsvoorwaarden voor verwarmingsinstallaties

bedrijfstemperatuur max. 80 °C / 176 °F
bedrijfsdruk max. 1,0 MPa / 10 bar / 145 PSI

Bedrijfsvoorwaarden gas-installaties

bedrijfstemperatuur -20 °C tot en met +70 °C (-4 °F tot en met +158 °F)
bedrijfsdruk max. 0,5 MPa / 5 bar / 72,5 PSI
Menginstallaties zijn onafhankelijk van de stromingsrichting toegestaan.

Materialenpersfitting

Brons: CC499K
roestvast staal 1.4401

Drukverlies-calculator

Web-applicatie voor eenvoudig en snel bepalen van de buisleidingdiameter voor drinkwater-, verwarmings- en gasleidingen met bijbehorende drukverliestabel over het totale systeem.

Onder voorbehoud van wijzigingen en fouten!

De actuele Z- en inbouwmaten en verdere technische informatie zijn te vinden op de Viega website en moeten vóór aanschaf, de planning, de installatiewerkzaamheden en het gebruik worden gecontroleerd. Onze producten worden continu geoptimaliseerd.





Deze productbeschrijving bevat belangrijke informatie over de keuze van het product of de installatie, de installatie en de inbedrijfstelling, evenals over het beoogde gebruik en, indien nodig, de onderhoudsmaatregelen. Deze informatie over producten, hun eigenschappen en toepassingstechnieken is gebaseerd op de momenteel geldende normen in Europa (bijv. EN) en/of in Duitsland (bijv. DIN/DVGW). Sommige passages in de tekst kunnen betrekking hebben op technische voorschriften in Europa/Duitsland. Deze moeten worden beschouwd als aanbevelingen voor andere landen waar geen overeenkomstige nationale voorschriften bestaan. De relevante nationale wetten, normen, voorschriften, normen en andere technische voorschriften hebben voorrang op de Duitse/Europese richtlijnen van deze productbeschrijving: De hier gepresenteerde informatie is niet bindend voor andere landen en gebieden en dient te worden opgevat als ondersteuning.











Toegestane buizen









buismateriaal	model	artikel	buiten-Ø	wanddikte	uitvoeringen
PE-Xc/Al/PE-Xc	4703	607 258	16	2,0	
		607 272	20	2,3	
		607 289	25	2,8	
		586 935	32	3,2	
		586 942	40	3,5	
		588 052	50	4,0	
		588 069	63	4,5	
	4705	607 210	16	2,0	
		607 234	20	2,3	
		607 241	25	2,8	
699 208		32	3,2		
PE	4704	607 302	16	2,0	mantelbuis zwart
		607 326	20	2,3	mantelbuis zwart
		761 455	25	2,8	mantelbuis zwart
PE-Xc/Al/PE-Xc	4704.1	691 455	16	2,0	mantelbuis blauw
		691 462	16	2,0	mantelbuis rood
		691 479	20	2,3	mantelbuis blauw
		691 486	20	2,3	mantelbuis rood
	4705.5	734 060	16	2,0	isolatie rondom 6 mm blauw ($\lambda=0,040$ W/(mK))
		734 077	16	2,0	isolatie rondom 6 mm rood ($\lambda=0,040$ W/(mK))
		751 401	20	2,3	isolatie rondom 6 mm blauw ($\lambda=0,040$ W/(mK))
		751 418	20	2,3	isolatie rondom 6 mm rood ($\lambda=0,040$ W/(mK))
	4705.1	679 606	16	2,0	
	PE-RT/Al/PE-RT	4705.01	751 425	16	2,0
751 432			16	2,0	
4708		662 585	16	2,0	
		662 592	20	2,3	
4708.1		662 608	16	2,0	PE-mantelbuis zwart
4708.5		662 622	16	2,0	isolatie rondom 6 mm blauw ($\lambda=0,040$ W/(mK))

buismateriaal	model	artikel	buiten-Ø	wanddikte	uitvoeringen
PE-Xc/Al/PE-Xc	4705.6	607 388	25	2,8	isolatie rondom 9 mm blauw ($\lambda=0,040$ W/(mK))
		784 805	25	2,8	isolatie rondom 9 mm rood ($\lambda=0,040$ W/(mK))
		761 202	32	3,2	isolatie rondom 9 mm blauw ($\lambda=0,040$ W/(mK))
		784 812	32	3,2	isolatie rondom 9 mm rood ($\lambda=0,040$ W/(mK))
	4705.4	830 755	16	2,0	rondom isolatie 13 mm grijs ($\lambda=0,040$ W/(mK))
		830 762	20	2,3	rondom isolatie 13 mm grijs ($\lambda=0,040$ W/(mK))
		830 779	25	2,8	rondom isolatie 13 mm grijs ($\lambda=0,040$ W/(mK))

Certificaten

Dubai	Dubai Central laboratory Department Attestation of Conformity Viega Smartpress, metal fittings for plastic piping system
	BCCA Certificate Viega Smartpress
BULGARKONTROLA	BULGARKONTROLA Certificate of Conformity Viega Smartpress
VUPS	VUPS Certificate Viega Smartpress
	AENOR Certificate Viega Smartpress
	Eurofins Certificate Viega Smartpress
	CSTB QB Certificate Viega Smartpress
Eurofins	Eurofins Certificate of sanitary conformity (ACS) Viega Smartpress
	WRAS Certificate Viega Smartpress
EMI	EMI certificate Profipress, Sanpress, Easytop, Sanpress Inox, Pexfit Pro Fosta, Smartpress, gunmetal threaded fittings
EMI	EMI Certificate of Constancy of Performance Smartpress/Pexfit Pro

	<p>ICIM Hygiene certificate Profipress, Profipress XL, Sanpress Inox, Sanpress Inox XL, Sanpress, Sanpress XL, Sanfix Fosta, Raxofix, Smartpress, gunmetal threaded fittings, soldered fittings</p>
	<p>IKRAM Product Certificate of Conformity Smartpress/Pexfit Pro, PE-Xc/Al/PE-Xc</p>
	<p>IKRAM Product Certificate of Conformity Smartpress, copper alloy/PPSU fittings</p>
	<p>IKRAM Product Certificate of Conformity Smartpress, stainless steel/PPSU fittings</p>
	<p>Gastec Certificate Smartpress G</p>
	<p>KOMO Product certificate PE-RT/Al pipes</p>
	<p>KOMO Product certificate PPSU Fittings</p>
	<p>KOMO Product certificate PE-Xc/Al pipes</p>
	<p>KOMO Product certificate Viega Smartpress PE-Xc/Al/PE-Xc piping system</p>
	<p>KOMO Product certificate Viega Smartpress PE-RT/Al/PE-RT piping system</p>
	<p>KIWA Product certificate PE-RT/Al pipes</p>

	<p>KIWA Product certificate PPSU Fittings</p>
	<p>KIWA Product certificate PE-Xc/Al pipes</p>
	<p>KIWA Product certificate Viega Smartpress PE-Xc/Al/PE-Xc piping system</p>
	<p>KIWA Product certificate Viega Smartpress PE-RT/Al/PE-RT piping system</p>
	<p>KOMO Product certificate Flexible corrugated protection pipes of PE</p>
	<p>KOMO Product certificate Metal fittings for plastics piping system Pexfit Pro/Smartpress</p>
	<p>KIWA Product certificate Metal fittings for plastic piping system Pexfit Pro/Smartpress</p>
<p>SINTEF</p>	<p>SINTEF Certificate Viega Smartpress</p>
<p>EITS</p>	<p>EITS Technical Approval Viega Smartpress</p>
<p>EITS</p>	<p>EITS Certificate Viega Smartpress</p>
	<p>RISE Certificate vieg Smartpress</p>
<p>STL</p>	<p>Singapore Test Lab Test Certificate Smartpress</p>
<p>UKRCERTIFICATION</p>	<p>LLC UKRCertification Certificate of conformity Pexfit Pro, Smartpress</p>

Z-maten

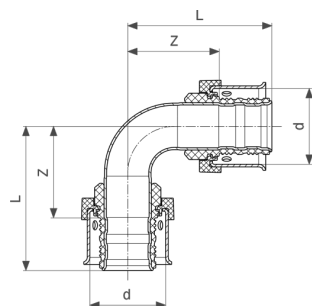

Viega Smartpress bocht 90°
- roestvast staal
model 6716

artikel	d	Z	L
729 844	16	26	39
729 851	20	25	39
729 868	25	27	46
729 875	32	35	59
731 922	40	70	94
731 939	50	83	112
731 946	63	93	128

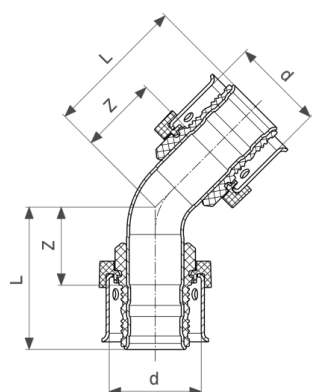

Viega Smartpress bocht 45°
- roestvast staal
model 6726

artikel	d	Z	L
730 154	25	18	37
730 161	32	23	48
733 995	40	50	74
734 008	50	58	87
734 015	63	65	100

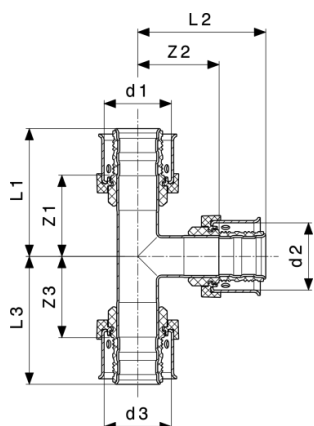

Viega Smartpress T-stuk
- roestvast staal
model 6718

artikel	d1	d2	d3	Z1	Z2	Z3	L1	L2	L3
729 929	16	16	16	27	27	27	40	40	40
729 936	16	20	16	28	24	26	42	38	42
729 967	20	16	16	31	31	26	44	44	40
729 950	20	16	20	24	28	24	38	42	38
729 974	20	20	16	24	24	27	38	38	42
729 943	20	20	20	24	24	24	38	38	38
730 048	25	16	16	25	31	30	43	45	44
730 000	25	16	20	25	31	29	43	45	43
729 998	25	16	25	25	31	25	43	45	43
730 017	25	20	20	25	29	29	43	43	43
730 024	25	20	25	25	29	25	43	43	43
730 055	25	25	16	25	25	30	43	43	44
730 031	25	25	20	25	25	29	43	43	43
729 981	25	25	25	25	25	25	43	43	43
730 079	32	16	25	31	33	27	55	46	45
730 086	32	16	32	26	35	26	50	48	50
730 093	32	20	25	31	31	27	55	45	45
730 109	32	20	32	26	33	26	50	47	50
730 116	32	25	25	31	26	27	55	45	45
730 123	32	25	32	26	28	26	50	47	50
730 062	32	32	32	28	28	28	53	53	53
732 769	40	25	32	52	35	38	76	53	63
732 776	40	25	40	52	35	52	76	53	76
732 783	40	32	32	53	34	41	76	58	65
732 790	40	32	40	53	34	53	76	58	76
732 752	40	40	40	52	53	52	76	76	75

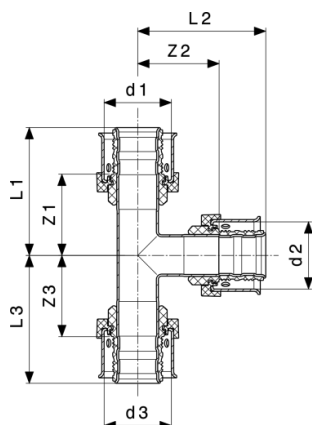

Viega Smartpress T-stuk
- roestvast staal
model 6718

artikel	d1	d2	d3	Z1	Z2	Z3	L1	L2	L3
731 953	50	25	50	61	38	61	90	59	90
732 806	50	32	50	61	37	61	90	62	90
732 813	50	40	50	61	55	61	90	80	90
731 984	50	50	50	61	61	61	90	90	90
732 837	63	25	63	66	42	66	101	60	101
732 844	63	32	63	66	41	66	101	65	101
732 851	63	40	63	66	60	66	101	83	101
732 868	63	50	63	66	64	66	101	93	101
732 820	63	63	63	66	66	66	101	101	101

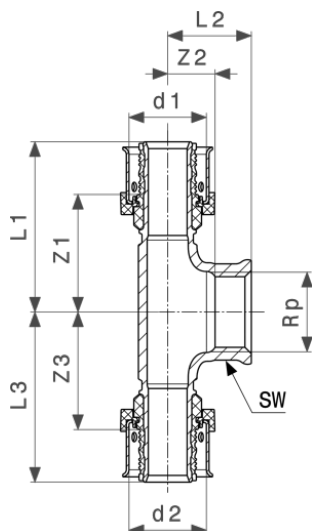

Viega Smartpress T-stuk
- roestvast staal
model 6717

artikel	d1	Rp	d2	Z1	Z2	Z3	L1	L2	L3	SW
729 882¹	16	½	16	33	7	33	47	22	47	
729 899¹	20	½	20	31	7	31	45	22	45	
729 905¹	25	¾	25	33	9	33	52	25	52	
729 912¹	32	¾	32	36	12	36	61	28	61	
733 308²	40	1	40	53	23	53	76	43	76	36
733 315²	50	1	50	61	27	61	90	46	90	36
733 322²	63	1	63	66	30	66	101	50	101	36

SW = Sleutelwijdte

1) brons

2) roestvast staal

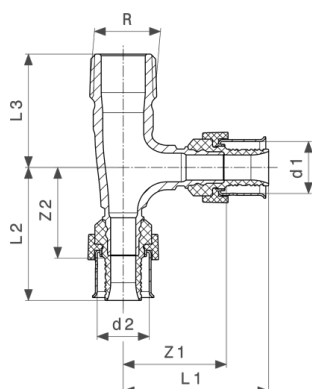

Viega Smartpress T-stuk
- brons
model 6726.4

artikel	R	d1	d2	Z1	Z2	L1	L2	L3	SW
730 444	½	16	16	33	29	47	43	36	18

SW = Sleutelwijdte

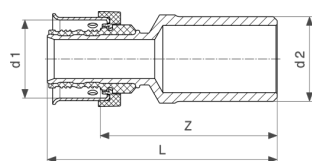

Viega Smartpress insteekstuk
- brons
model 6713

artikel	VS	PMP	Z	L
729 660	16	15	47	60
729 677	20	22	47	60
729 684	25	22	46	65
729 691	32	28	49	74
733 421	40	35	72	95
733 438	50	42	86	115

VS = voor Viega Smartpress

PMP = voor persfittingen van metalen perssystemen

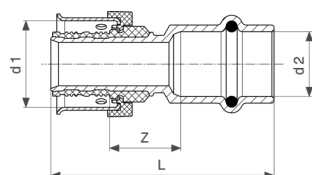

Viega Smartpress overgangsstuk
- brons
model 6713P

artikel	VS	PMP	Z	L
753 894	16	12	21	52
730 451	16	15	21	56
730 468	20	15	17	53
756 086	20	22	21	59
730 475	25	22	20	61

VS = voor Viega Smartpress

PMP = voor persfittingen van metalen perssystemen

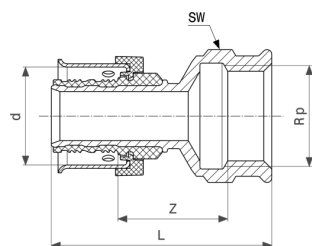

Viega Smartpress overgangsstuk
- brons
model 6712

artikel	d	Rp	Z	L	SW
729 608	16	½	21	49	26
729 615	16	¾	23	52	31
729 622	20	½	17	46	26
729 639	20	¾	19	49	31
729 646	25	¾	18	53	31
729 653	32	1	20	64	38
733 391	40	1¼	42	87	47
733 407	50	1½	43	94	53
733 414	63	2	42	103	66

SW = Sleutelwijdte

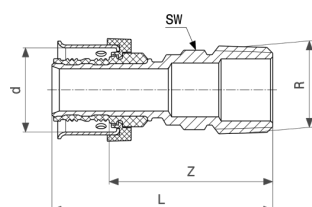

Viega Smartpress overgangsstuk
- brons
model 6711

artikel	d	R	Z	L	SW
729 523	16	⅝	39	53	14
729 530	16	½	43	57	18
729 547	16	¾	46	60	22
729 554	20	½	40	54	18
729 561	20	¾	42	56	22
729 578	25	¾	42	61	22
729 585	25	1	50	68	27
729 592	32	1	49	74	27
733 278	40	1¼	74	97	43
733 285	50	1½	75	104	50
733 292	63	2	82	117	62

SW = Sleutelwijdte

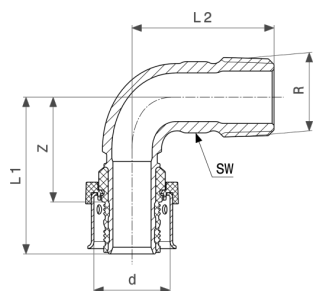

Viega Smartpress overgangstukbocht 90°
- brons
model 6714

artikel	d	R	Z	L1	L2	SW
729 707	16	½	33	47	36	18
729 714	20	½	28	42	38	18
729 721	20	¾	31	45	42	23
729 738	25	¾	31	50	44	23
729 745	32	1	38	63	52	29

SW = Sleutelwijdte

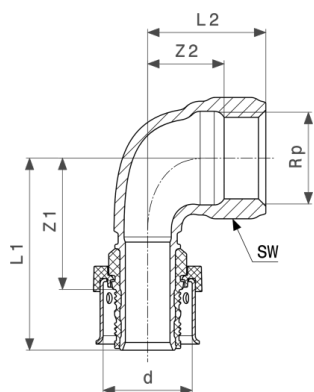

Viega Smartpress overgangstukbocht 90°
- brons
model 6714.1

artikel	d	Rp	Z1	Z2	L1	L2	SW
730 352	16	½	34	11	48	26	26
730 345	16	¾	32	12	46	23	22
730 369	20	½	30	12	44	27	26
730 376	20	¾	33	12	47	28	32
730 383	25	¾	34	11	53	27	32

SW = Sleutelwijdte

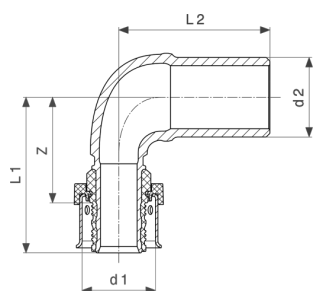

Viega Smartpress insteekbocht 90°
- brons
model 6793

artikel	VS	PMP	Z	L1	L2
730 321	16	15	28	41	38
730 338	20	22	29	43	42

VS = voor Viega Smartpress

PMP = voor persfittingen van metalen perssystemen

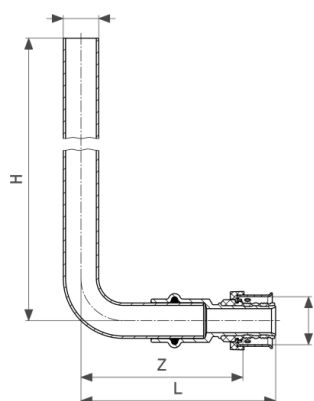

Viega Smartpress aansluitbocht
- koper
model 6776

artikel	VS	PMP	H	Z	L
753 863	16	12	200	76	89
750 169	16	15	200	76	89
756 079	16	15	350	76	89

VS = voor Viega Smartpress

PMP = voor persfittingen van metalen perssystemen

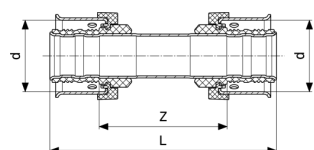

Viega Smartpress koppeling
- roestvast staal
model 6715

artikel	d	Z	L
729 752	16	40	67
729 769	20	38	65
729 783	25	39	77

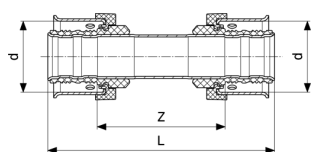

Viega Smartpress koppeling
- roestvast staal
model 6715

artikel	d	Z	L
729 813	32	43	92
733 339	40	73	120
733 353	50	75	133
733 377	63	80	150

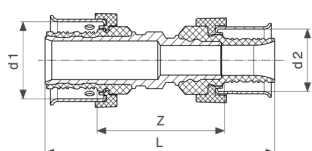

Viega Smartpress reduceerkoppeling
- brons
model 6715.2

artikel	d1	d2	Z	L
729 776	20	16	35	62
729 790	25	16	35	67
729 806	25	20	32	64
729 820	32	20	35	73
729 837	32	25	34	77
733 346	40	32	54	102
733 360	50	40	73	126
733 384	63	50	77	141

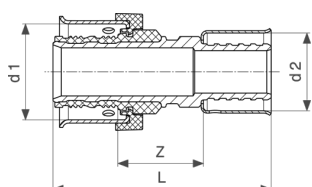

Viega Smartpress G overgangsstukkoppeling
- brons
model 6715G

artikel	d1	d2	Z	L
730 482	20	16	18	47

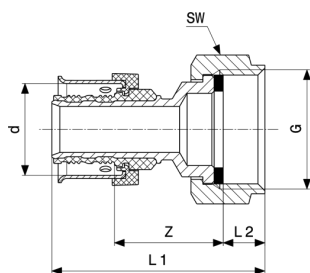

Viega Smartpress schroefkoppeling
- brons
model 6763

artikel	d	G	Z	L1	L2	SW
730 208	16	½	27	43	5	23
730 215	16	¾	28	51	9	30
730 222	20	½	23	42	5	23
730 239	20	¾	24	47	9	30
730 246	25	¾	26	53	9	30
730 253	32	1¼	28	65	12	50
733 445	40	1¼	46	81	12	50
733 452	40	1½	49	82	9	52
733 469	50	1¾	50	89	10	59
733 476	50	2%	54	94	11	75
733 483	63	2%	54	98	11	75

SW = Sleutelwijdte

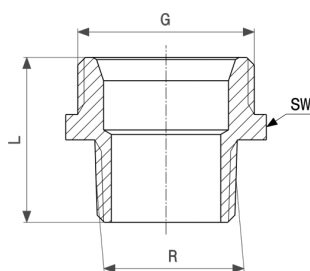

Overgangsstuknippel
- brons of silicium brons
model 3246

artikel	R	G	L	SW
449 339	½	½	30	22
441 524	½	¾	21	27
449 346	¾	¾	33	28

SW = Sleutelwijdte

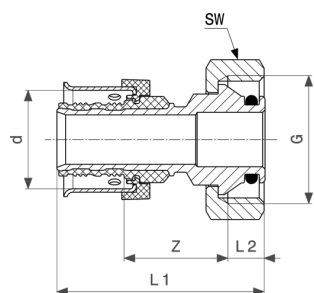

Viega Smartpress schroefkoppeling
- brons
model 6735

artikel	d	G	Z	L1	L2	SW
730 598	16	¾	25	46	8	30
730 604	20	¾	22	43	8	30
730 611	25	¾	21	47	8	30

SW = Sleutelwijdte

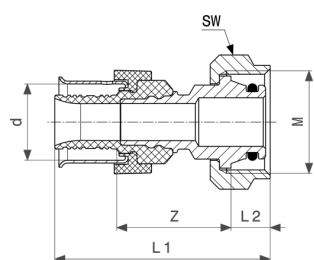

Viega Smartpress schroefkoppeling
- brons
model 6783

artikel	d	M	Z	L1	L2	SW
730 307	16	22	25	48	9	26
730 314	16	24	26	49	10	27

SW = Sleutelwijdte

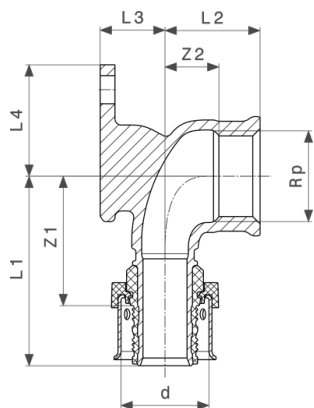

Viega Smartpress muurplaat
- brons
model 6725.5

artikel	d	Rp	Z1	Z2	L1	L2	L3	L4
729 479	16	½	33	7	47	22	13	27
729 486	20	½	30	7	44	22	15	27
729 493	20	¾	34	9	48	25	18	31

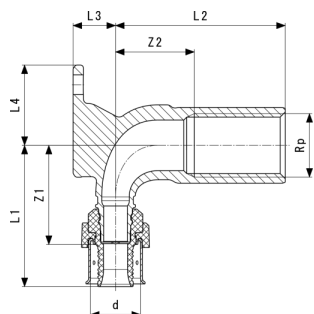

Viega Smartpress muurplaat
- brons
model 6725

artikel	Z1	Z2	L1	L2	L3	L4
783 921	33	26	47	56	14	27

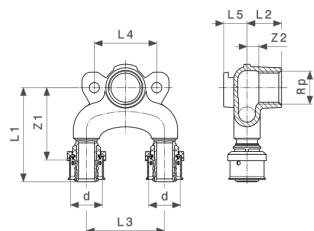

Viega Smartpress doorstroommuurplaat
- brons
model 6725.7

artikel	d	Rp	Z1	Z2	L1	L2	L3	L4	L5
730 413	16	½	51	7	65	22	50	40	13
730 420	20	½	46	7	60	22	50	40	15
730 437	25	½	48	7	66	22	50	40	15

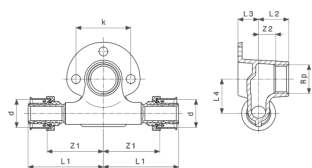

Viega Smartpress muurplaat-T-stuk
- brons
model 6724.3

artikel	d	Rp	Z1	Z2	L1	L2	L3	L4	k
729 509	16	½	46	7	60	22	13	25	40
729 516	20	½	41	7	55	22	15	25	40

k = Boutdiameter-Ø

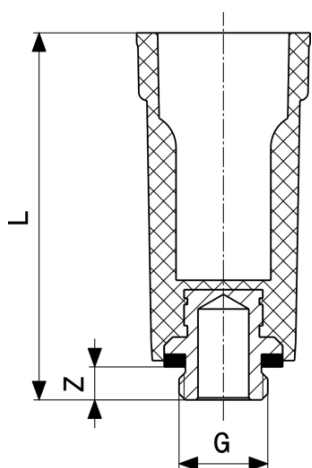

Afpersstoppen
- kunststof
model 1516.113

artikel	G	Z	L
116 644	¾	7	85
100 766	½	11	92
107 666	¾	9	87

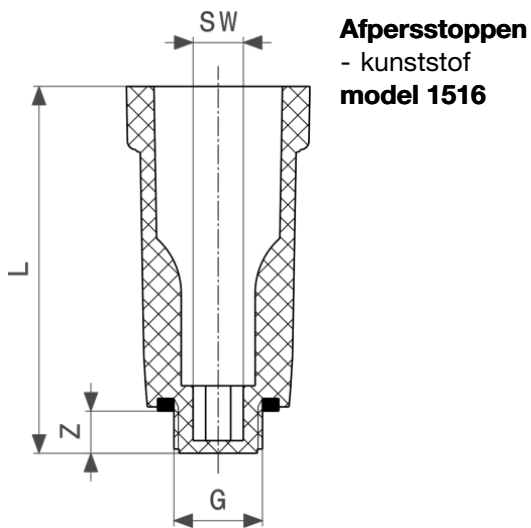

artikel	G	Z	L	SW
107 796	3/8	10	87	8
100 124	1/2	10	87	10
102 746	3/4	13	90	14

SW = Sleutelwijdte

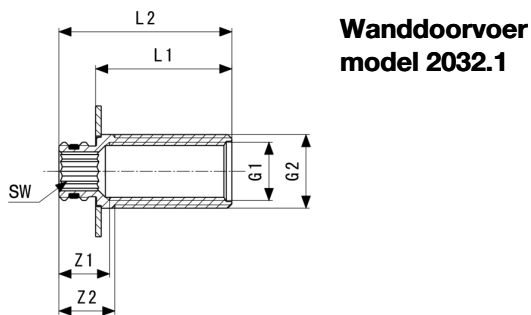

artikel	G1	G2	L	Z1	Z2	L1	L2	SW
764 067	1/2	3/4	35	18	20	37	50	12
764 074	1/2	3/4	47	17	20	49	62	12

SW = Sleutelwijdte

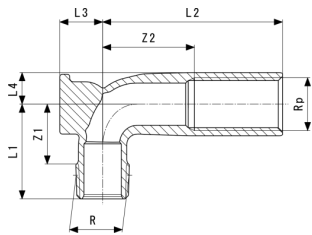

Muurplaat voor Prevista
- silicium brons
model 8055.2

artikel	Z1	Z2	L1	L2	L3	L4
785 178	24	37	38	72	17	12

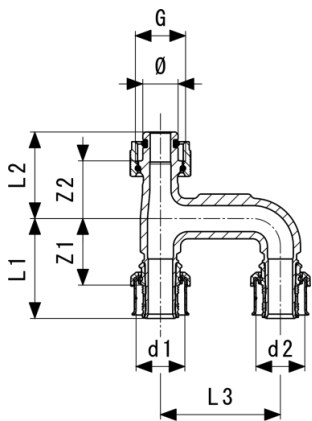

Viega Smartpress uitbreidingsstuk
- brons
model 6725.78

artikel	d1	d2	G	Z1	Z2	L1	L2	L3	Ø
796 754	16	16	½	32	23	45	35	50	15
796 761	20	20	½	28	24	42	36	50	15
796 778	25	25	½	31	25	49	37	50	15

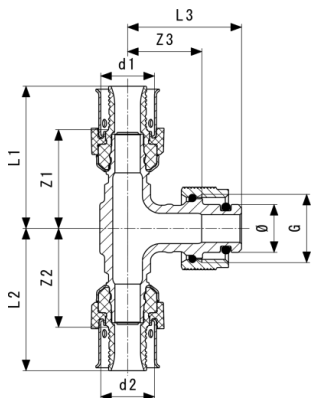

Viega Smartpress overgangs-T-stuk
- brons
model 6718.8

artikel	Ø	Z1	Z2	Z3	L2	L1	L3
777 012	15	27	27	24	41	41	36
777 005	15	30	30	23	44	44	35

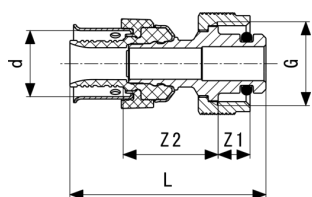

Viega Smartpress overgangsstuk
- brons
model 6711.8

artikel	Z1	Z2	L
776 985	8	24	49

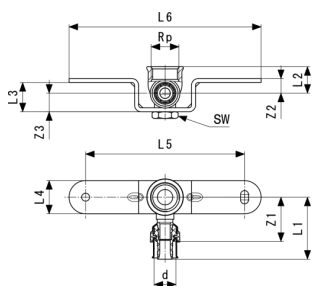

Viega Smartpress montage-unit
- staal verzinkt
model 6723

artikel	d	Rp	Z1	Z2	Z3	L1	L2	L3	L4	L5
750 152	16	½	33	11	14	47	20	22	25	120

artikel	d	Rp	L6	SW
750 152	16	½	145	17

SW = Sleutelwijdte

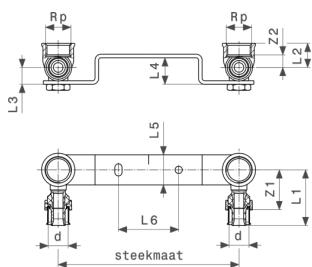

Viega Smartpress montage-unit
- staal verzinkt
model 6724

artikel	d	Rp	steekmaat	Z1	Z2	L1	L2	L3	L4	L5
730 130	16	¾	120	33	5	47	16	14	18	25
730 147	16	½	150	33	5	47	20	14	22	25

artikel	d	Rp	steekmaat	L6
730 130	16	¾	120	40
730 147	16	½	150	50

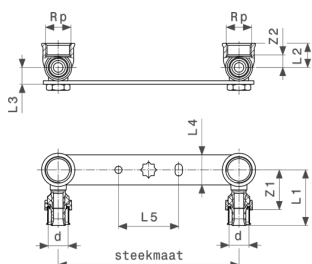

Viega Smartpress montage-unit
- staal verzinkt
model 6724.1

artikel	d	Rp	steekmaat	Z1	Z2	L1	L2	L3	L4	L5
730 390	16	½	150	33	8	47	20	14	25	50

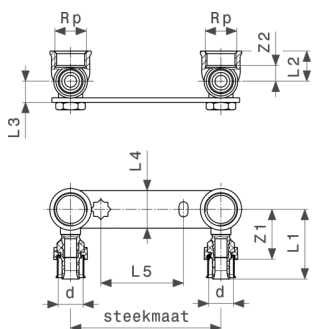

Viega Smartpress montage-unit
- staal verzinkt
model 6724.2

artikel	d	Rp	steekmaat	Z1	Z2	L1	L2	L3	L4	L5
730 406	16	½	80/100	33	5	47	20	14	25	55

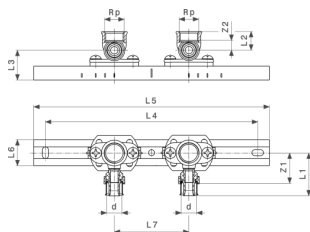

Viega Smartpress montage-unit
- staal verzinkt
model 6741

artikel	d	Rp	Z1	Z2	L1	L2	L3	L4	L5	L6
730 628	16	½	33	7	47	22	32	228	253	28

artikel	d	Rp	L7
730 628	16	½	80

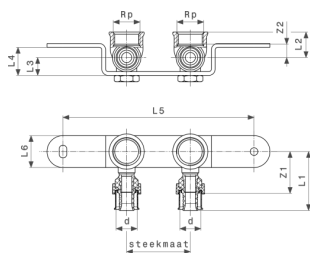

Viega Smartpress montage-unit
- staal verzinkt
model 6723.1

artikel	d	Rp	steekmaat	Z1	Z2	L1	L2	L3	L4	L5
730 499	16	½	35/45/50	33	5	47	20	10	22	150

artikel	d	Rp	steekmaat	L6
730 499	16	½	35/45/50	25

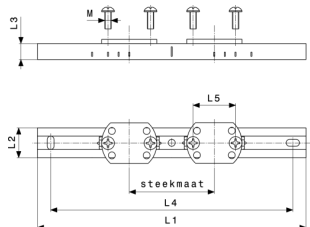

Houder
- staal verzinkt
model 2141.3

artikel	steekmaat	L1	L2	L3	L4	L5	M
581 701	80-150	253	28	15	228	40	6

M = Draadsoort



Houder
- staal verzinkt
model 2141.4

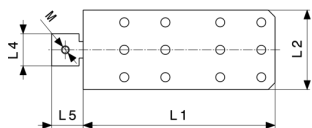

artikel	L1	L2	L3	L4	L5	M
586 706	140	58	43	24	23	6

M = Draadsoort

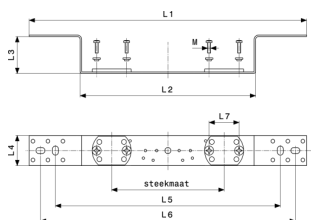

Houder
- staal verzinkt
model 2021.7

artikel	steekmaat	L1	L2	L3	L4	L5	L6	L7	M
651 350	70/100/150	370	234	48	40	300	340	40	4

M = Draadsoort

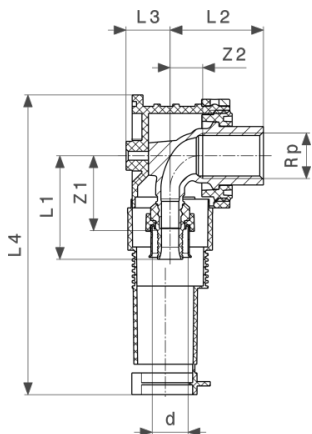

Viega Smartpress aansluitdoos 90°
- brons
model 6720.01

artikel	d	Rp	Z1	Z2	L1	L2	L3	L4
730 581	16	½	34	15	48	43	20	138

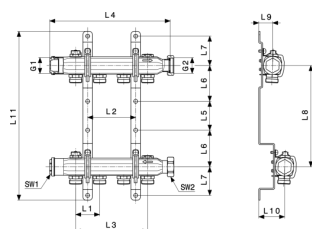

Verdeler
- roestvast staal
model 1078

artikel	u	L1	L2	L3	L4	L5	L6	L7	L8	L9
586 225	2	50			142	60	75	60	210	28
586 232	3	50	50	100	192	60	75	60	210	28
586 249	4	50	100	150	242	60	75	60	210	28
587 550	5	50	150	200	292	60	75	60	210	28
587 567	6	50	200	250	342	60	75	60	210	28
587 574	7	50	250	300	392	60	75	60	210	28
587 581	8	50	300	350	442	60	75	60	210	28
587 598	9	50	350	400	492	60	75	60	210	28
587 604	10	50	400	450	542	60	75	60	210	28
587 611	11	50	450	500	592	60	75	60	210	28
587 628	12	50	500	550	642	60	75	60	210	28

artikel	u	L10	L11	SW1	SW2	G1	G2
586 225	2	53	350	25	37	¾	1
586 232	3	53	350	25	37	¾	1
586 249	4	53	350	25	37	¾	1
587 550	5	53	350	27	37	¾	1
587 567	6	53	350	25	37	¾	1
587 574	7	53	350	25	37	¾	1
587 581	8	55		25	37	¾	1
587 598	9	55		25	37	¾	1
587 604	10	53	350	25	37	¾	1
587 611	11	53	350	25	37	¾	1
587 628	12	53	350	25	37	¾	1

SW = Sleutelwijdte

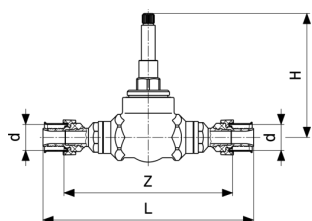

Viega Smartpress inbouw-vrijstroomventiel
- messing
model 6770

artikel	d	Z	L	H
730 260	16	109	136	79
730 277	20	101	129	79

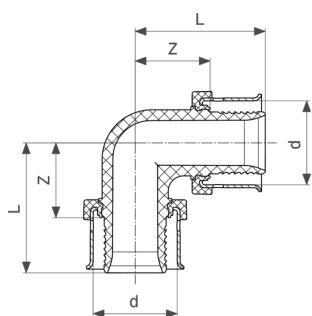

Viega Smartpress bocht 90°
- PPSU
model 4716

artikel	d	Z	L
608 613	16	16	30
608 637	20	18	31
608 644	25	21	38

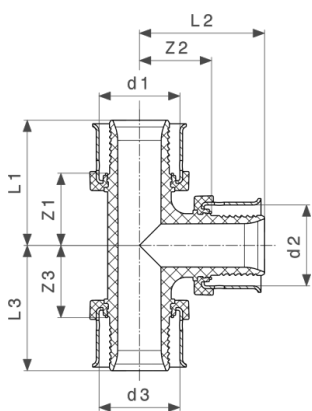

Viega Smartpress T-stuk
- PPSU
model 4718

artikel	d1	d2	d3	Z1	Z2	Z3	L1	L2	L3
608 781	16	16	16	16	16	16	30	30	30
608 842	16	20	16	18	16	18	31	30	31

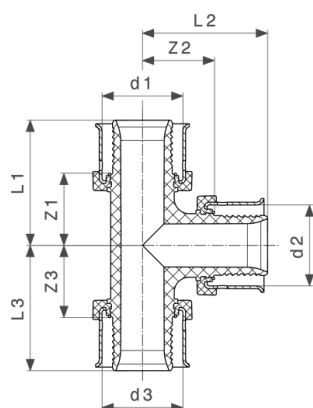

Viega Smartpress T-stuk
- PPSU
model 4718

artikel	d1	d2	d3	Z1	Z2	Z3	L1	L2	L3
608 880	20	16	16	16	18	16	29	31	29
608 897	20	16	20	16	18	16	29	31	29
608 903	20	20	16	18	18	18	32	32	32
608 804	20	20	20	18	18	18	32	32	32
608 910	25	16	16	17	21	17	34	34	30
608 927	25	16	20	17	21	17	34	34	30
608 934	25	16	25	17	21	17	34	34	34
608 965	25	20	20	18	21	18	36	34	32
608 972	25	20	25	18	21	18	36	34	36
608 941	25	25	16	21	21	21	38	38	34
608 958	25	25	20	21	21	21	38	38	34
608 811	25	25	25	21	21	21	38	38	38

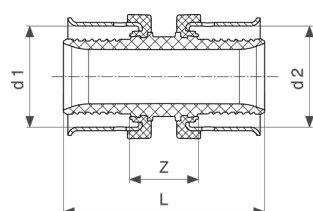

Viega Smartpress koppeling
- PPSU
model 4715

artikel	d1	d2	Z	L
608 668	16	16	14	41
608 729	20	16	14	41
608 682	20	20	14	41
608 743	25	16	14	45
608 736	25	20	14	45
608 699	25	25	14	49

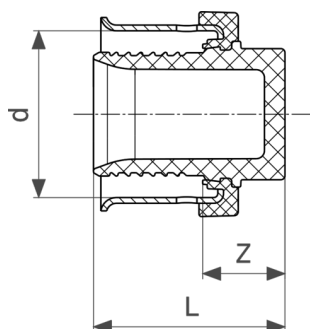

Viega Smartpress kap
- PPSU
model 4756

artikel	d	Z	L
608 569	16	9	23
608 583	20	9	23
608 590	25	10	27

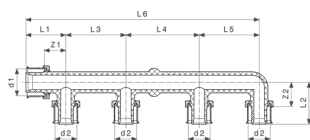

Viega Smartpress verdeler
- PPSU
model 4733

artikel	d1	d2	Z1	Z2	L1	L2	L3	L4	L5	L6
610 111*	20	16	16	18	30	32	45	55		130
610 135*	20	16	16	18	30	32	45	55	45	175
610 098	20	16	17	18	30	32	45			75

* = levering alleen nog uit magazijnvoorraad

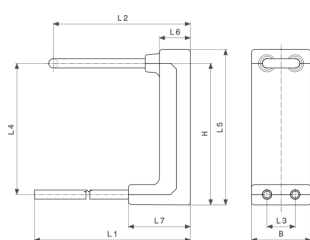

Viega Smartpress radiatoraansluitblok
- meerlagenbuis
model 6797.6

artikel	H	L1	L2	L3	L4	L5	L6	L7	B
730 512*	250	423	244	50	233	275	55	110	105

* = levering alleen nog uit magazijnvoorraad

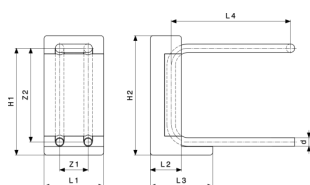

**Radiatoraansluitblok
model 1097.6**

artikel	d	Z1	Z2	L1	L2	L3	L4	H1	H2
364 045	15	50	165	105	55	110	210	188	210
379 698	15	50	235	105	55	110	210	258	280

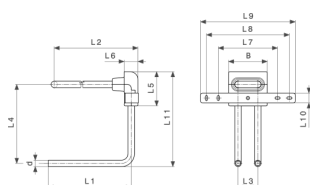

**Viega Smartpress radiatoraansluitblok
- meerlagenbuis
model 6797.7**

artikel	d	L1	L2	L3	L4	L5	L6	L7	L8	L9
730 529	16	210	392	50	200	87	35	150	210	240

artikel	d	L10	L11	B
730 529	16	25	232	98

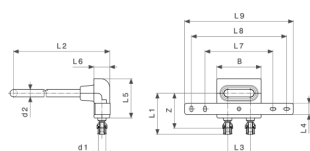

**Viega Smartpress radiatoraansluitblok
- roestvast staal
model 6775.31**

artikel	d1	d2	Z	L1	L2	L3	L4	L5	L6	L7
730 505	16	15	78	91	395	50	25	87	34	150

artikel	d1	d2	L8	L9	B
730 505	16	15	210	240	98

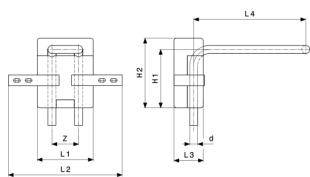

**Radiatoraansluitblok
model 1097.9**

artikel	d	H	Z	L1	L2	L3	L4	H1	H2
586 379	15	150	50	105	214	55	210	109	130

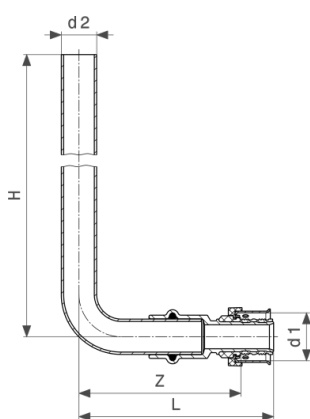

Viega Smartpress radiatoraansluitset
- roestvast staal
model 6777

artikel	VS	PMP	H	Z	L
730 291	16	15	350	73	86

VS = voor Viega Smartpress

PMP = voor persfittingen van metalen perssystemen

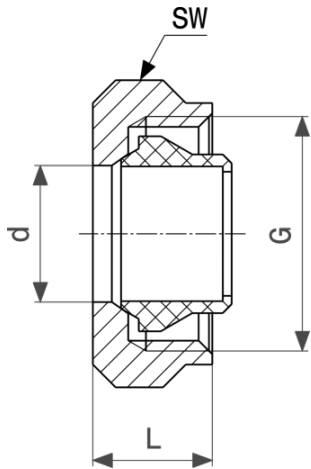

Schroefkoppeling
- messing vernikkeld
model 94385.2

artikel	d	G	L	SW
636 050	15	¾	14	30

SW = Sleutelwijdte

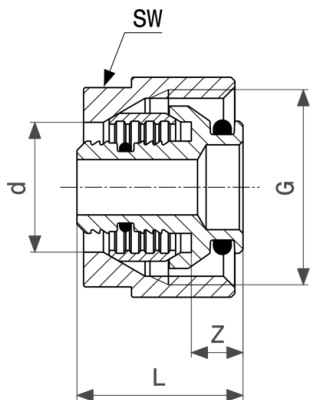

Schroefkoppeling
- messing vernikkeld
model 1037

artikel	d	G	Z	L	SW
614 522	16	¾	6	25	27

SW = Sleutelwijdte

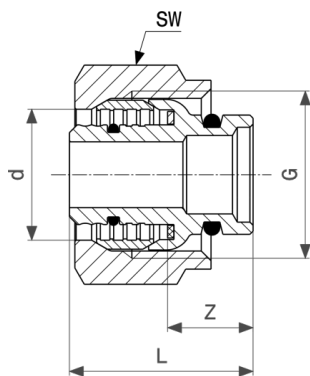

Klemringbevestiging
- messing
model 1019

artikel	d	s	Z	L	SW	G
356 682	16	2	13	29	30	¾

SW = Sleutelwijdte

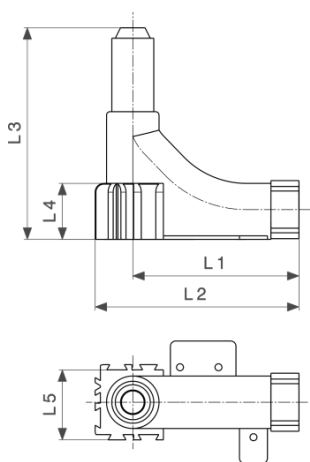

Buisgeleidingsbocht 90°
model 1072.3

artikel	L1	L2	L3	L4	L5
309 855	95	117	121	32	37

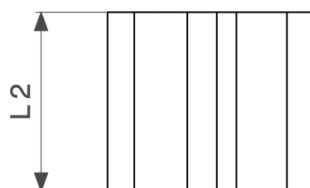

**Afstandstuk
model 1072.25**

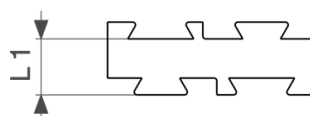

artikel	L1	L2
360 382*	10	32

* = levering alleen nog uit magazijnvoorraad

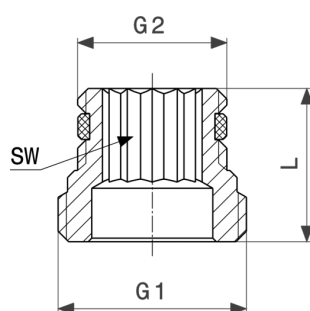

**Adapterset
- messing
model 1096.8**

artikel	G1	G2	L	SW
357 122	½	¾	22	12

SW = Sleutelwijdte

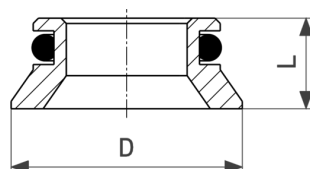

**Adapterset
model 1096.9**

artikel	D	L
308 872	22	9

D = Buitendiameter

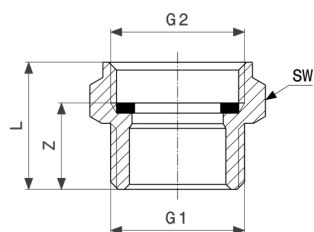

Adapterset
- messing
model 1022.7

artikel	G1	G2	Z	L	SW
279 547	¾	¾	14	22	30

SW = Sleutelwijdte

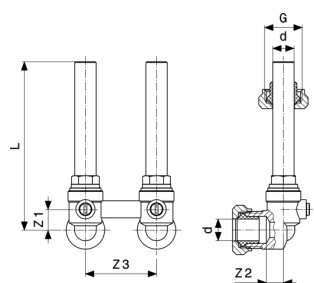

Radiatoraansluitset
- messing met vernikkeld
model 1097.7

artikel	d	G	Z1	Z2	Z3	L
364 052	15	¾	15	11	50	118

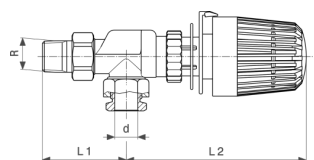

Haaksverkeerde radiatorkraan
- messing vernikkeld
model 1075.96

artikel	d	R	L1	L2
360 405	15	½	56	120

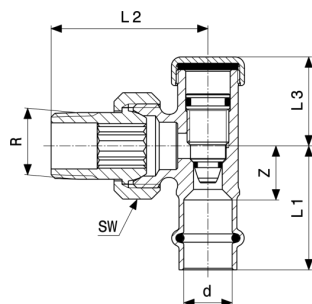

Sanpress retourventiel
- brons
model 2272.1

artikel	d	R	Z	L1	L2	L3	SW
326 357	15	½	17	39	50	28	29

SW = Sleutelwijdte

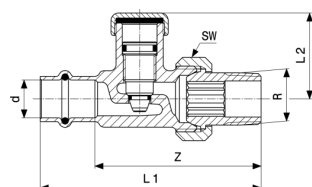

Sanpress retourventiel
- brons
model 2272.2

artikel	d	R	Z	L1	L2	SW
326 364	15	½	67	89	35	29

SW = Sleutelwijdte

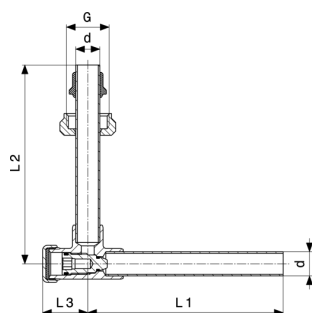

Radiatoraansluitset
- messing vernikkeld
model 2272.5

artikel	d	G	L1	L2	L3
360 399	15	¾	121	123	28

Impressie

Viega Nederland BV

Amsterdamsestraatweg 45-G
1411 AX Naarden

Postbus 5170
1410 AD Naarden

Kamer van Koophandel Gooi en Eemland nr. 32088642
BTW nr. NL810182713B01

Contact persoon:
Dhr. C.J.A.A. Jongen (directeur)

Bij het Submittal Package gaat het om vrijblijvende informatie die aan u ter beschikking wordt gesteld. Alle inhoud van dit Submittal Package wordt met veel zorg samengesteld. Toch kunnen wij de actualiteit, juistheid en volledigheid van de informatie niet garanderen. Het Submittal Package wordt bij een bestelling geen onderdeel van de overeenkomst.