

Temponox
submittal package



Inhoudsopgave

1	Productgroepenbeschrijving	3
2	Certificaten	5
3	Z-maten	6
4	Impressie	29

Productgroepenbeschrijving

Stromingsgeoptimaliseerd persfittingsysteem met persfittings van roestvast staal 1.4301 en buizen van roestvast staal 1.4520. Persfitting ter bescherming van het afdichtingselement, uitgerust met cilindrische buisgeleiding. Persfittings vanaf d76,1 met roestvast stalen snijring voor borging van de mechanische belasting van de verbinding. Buizen zijn ter bescherming voorzien van buisstoppen. De perskracht is voor en achter de zitting van het afdichtingselement. Geschikt voor opbouw- en inbouwinstallaties van stijg- en etageleidingen-installaties.

Markering

Fabrikant, buismaat, charge, bruine punt op persuiteinde, symbool »Niet voor drinkwaterinstallaties toegestaan«, bruine lijn op de buizen, bruine buisstoppen, bruine stickers afneembaar als persindicator vanaf d76,1



Persfittings met SC-Contur

Per ongeluk niet-geperste verbindingen worden duidelijk zichtbaar ondicht bij het vullen van de installatie. Viega garandeert het herkennen van niet-geperste fittingen in de volgende drukbereiken:

min. waterdruk 0,1 MPa / 100 kPa / 1 bar / 14,5 PSI

max. waterdruk 0,65 MPa / 650 kPa / 6,5 bar / 94,3 PSI

min. luchtdruk: 22 hPa / 2,2Kpa / 22mbar / 0,3 PSI

max. luchtdruk: 0,3 MPa / 300 kPa / 43,5 PSI

Afdichtingselementen

EPDM (ethyleen-propyleen-dieenrubber), zwart, voorgemonteerd

Aanwijzing

De afdichtingsmaterialen van het persverbindingssysteem zijn onderhevig aan thermische veroudering, die afhangt van de mediatemperatuur en de bedrijfsduur.

Hoe hoger de mediumtemperatuur, hoe sneller de thermische veroudering van het afdichtingsmateriaal verloopt.

In het geval van speciale bedrijfsomstandigheden, bijvoorbeeld industriële warmteterugwinningssystemen, moeten de specificaties van de fabrikant van het apparaat worden vergeleken met de specificaties van het persverbindingssysteem.

Voordat u het persverbindingssysteem buiten de beschreven toepassingsgebieden gebruikt of bij twijfel over de juiste materiaalkeuze, neem dan contact op met Viega.

Diameters

Fittingen: d15–54 en 76,1–108,0, buis: d15–54 en 64,0–108,0

Gereedschappen

De veilige werking van Viega persfittingsystemen hangt in eerste instantie af van de storingvrije toestand van de gebruikte persgereedschappen. Viega adviseert het gebruik van Viega persgereedschap voor het persen van Viega persfittings. Viega persgereedschap moet regelmatig worden onderhouden door geautoriseerde servicepartners.

Toepassingsgebied

Gesloten koel- en verwarmingsinstallaties
Persluchtinstallaties
Zonne-energie-installatie met vlakke collectoren
Zonne-energie-installatie met vacuümbuiscollectoren (alleen met FKM-afdichtingselement)
Industriële toepassingen

Aanwijzing

De systeemcomponenten moeten worden beschermd tegen hoge chlorideconcentraties zowel van het medium als door invloeden van buitenaf. Het gebruik van het systeem voor andere dan de beschreven toepassingen en media moet worden afgestemd met Viega! Gedetailleerde informatie over gebruik, beperkingen en nationale normen en richtlijnen vindt u in de productinformatie, hetzij gedrukt of op de Viega website.

Aanwijzing – normen en toelatingen

persfittingsysteem met persfittings en buizen volgens NEN EN 10088-2 en NEN EN 10312.
Raadpleeg bij toepassing in verwarmingsinstallaties de VDI-richtlijn 2035 en NEN EN 12828.

Bedrijfsvoorwaarden met EPDM-afdichtingselement

Het Temponox persverbindingssysteem kan worden gebruikt met de volgende bedrijfsparameters:
verwarmingssystemen volgens NEN EN 12828
bedrijfstemperatuur max. 105 °C / 221 °F

Het Temponox persfittingsysteem is ontworpen voor de nominale druk PN 16.

Materialenpersfitting

Roestvast staal 1.4301

Materialen buizen

Roestvast staal 1.4520

Drukverlies-calculator









Web-applicatie voor eenvoudig en snel bepalen van de buisleidingdiameter voor drinkwater-, verwarmings- en gasleidingen met bijbehorende drukverliestabel over het totale systeem.

Onder voorbehoud van wijzigingen en fouten!

De actuele Z- en inbouwmaten en verdere technische informatie zijn te vinden op de Viega website en moeten vóór aanschaf, de planning, de installatiewerkzaamheden en het gebruik worden gecontroleerd. Onze producten worden continu geoptimaliseerd.

Deze productbeschrijving bevat belangrijke informatie over de keuze van het product of de installatie, de installatie en de inbedrijfstelling, evenals over het beoogde gebruik en, indien nodig, de onderhoudsmaatregelen. Deze informatie over producten, hun eigenschappen en toepassingstechnieken is gebaseerd op de momenteel geldende normen in Europa (bijv. EN) en/of in Duitsland (bijv. DIN/DVGW). Sommige passages in de tekst kunnen betrekking hebben op technische voorschriften in Europa/Duitsland. Deze moeten worden beschouwd als aanbevelingen voor andere landen waar geen overeenkomstige nationale voorschriften bestaan. De relevante nationale wetten, normen, voorschriften, normen en andere technische voorschriften hebben voorrang op de Duitse/Europese richtlijnen van deze productbeschrijving: De hier gepresenteerde informatie is niet bindend voor andere landen en gebieden en dient te worden opgevat als ondersteuning.

Certificaten

	<p>DNV GL Type Approval Certificate Temponox</p>
	<p>TÜV Association Certificate Profipress, Sanpress, Sanpress Inox, Prestabo (d 15 - 108), Temponox</p>
	<p>Bureau Veritas Type Approval Certificate Temponox</p>
	<p>CSTB Certificate Temponox</p>
	<p>CSTB QB Certificate Temponox</p>
	<p>Lloyd's Register Type Approval Certificate Temponox</p>
<p>VIK-HR</p>	<p>VIK-HR INSpection Certificate 3.2 Temponox</p>
	<p>RINA Type Approval Certificate Temponox / Temponox XL</p>
	<p>ITB National Technical Assessment Temponox</p>
<p>EITS</p>	<p>EITS Certificate Temponox</p>
<p>IZV</p>	<p>IZV Certificate Temponox</p>

Z-maten

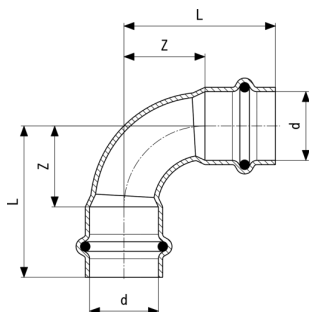

Temponox bocht 90°
- roestvast staal
model 1716

artikel	d	L	Z
809 638	15	38	16
809 645	18	40	18
809 652	22	49	26
809 669	28	58	34
809 676	35	59	33
809 683	42	87	50
809 690	54	105	65

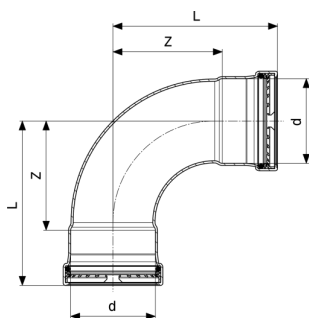

Temponox XL bocht 90°
- roestvast staal
model 1716XL

artikel	d	Z	L
808 884	76,1	99	149
808 891	88,9	115	165
808 907	108,0	138	198

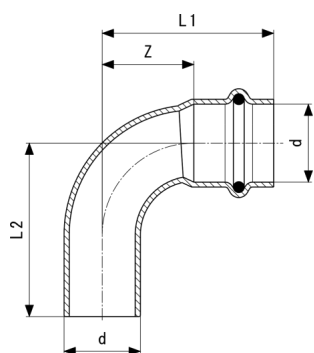

Temponox bocht 90°
- roestvast staal
model 1716.1

artikel	d	Z	L1	L2
808 921	15	16	38	40
808 945	22	26	49	50
809 751	28	34	58	59
809 768	35	33	59	62
809 775	42	50	87	88
809 782	54	65	105	107

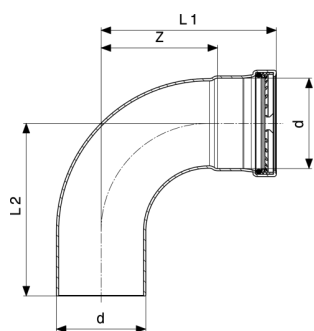

Temponox XL bocht 90°
- roestvast staal
model 1716.1XL

artikel	d	Z	L1	L2
809 805	76,1	99	149	147
809 812	88,9	115	165	162
809 829	108,0	138	198	195

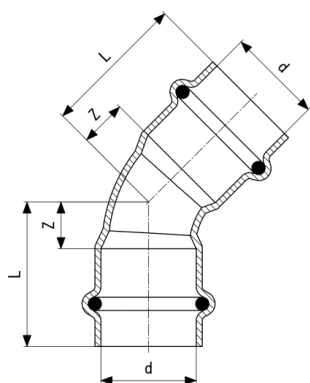

Temponox bocht 45°
- roestvast staal
model 1726

artikel	d	Z	L
809 843	15	7	29
809 850	18	7	29
809 867	22	11	34
809 874	28	14	38
809 881	35	15	41
809 898	42	21	57
809 904	54	27	67

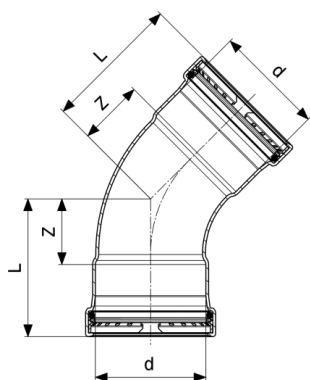

Temponox XL bocht 45°
- roestvast staal
model 1726XL

artikel	d	Z	L
809 928	76,1	46	96
809 935	88,9	52	102
809 942	108,0	61	121

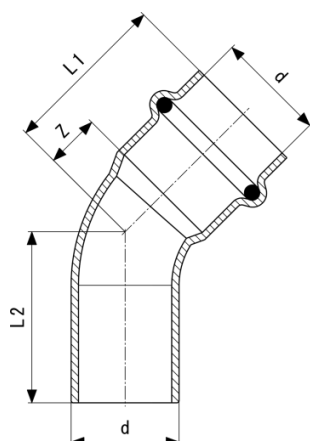

Temponox bocht 45°
- roestvast staal
model 1726.1

artikel	d	Z	L1	L2
809 966	15	7	29	29
809 973	18	7	29	31
809 980	22	11	34	35
809 997	28	14	38	39
810 009	35	15	41	42
810 016	42	21	57	59
810 023	54	27	67	67

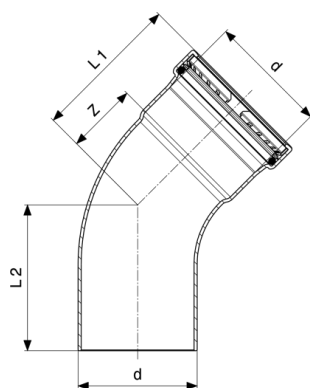

Temponox XL bocht 45°
- roestvast staal
model 1726.1XL

artikel	d	Z	L1	L2
810 047	76,1	46	96	93
810 054	88,9	52	102	99
810 061	108,0	61	121	119

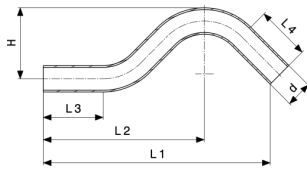

Temponox sprongbochten
- roestvast staal
model 1709.3

artikel	d	L1	L2	L3	L4	H
810 085	15	148	104	39	39	48
810 092	18	169	118	45	45	52
810 108	22	190	134	50	50	59

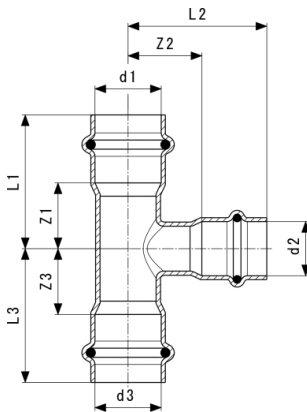

Temponox T-stuk
- roestvast staal
model 1718

artikel	d1	d2	d3	Z1	Z2	Z3	L1	L2	L3
810 122	15	15	15	41	22	19	41	44	41
810 252	15	18	15	21	25	21	43	47	43
810 269	15	22	15	21	27	21	43	50	43
810 290	18	15	18	21	23	21	43	45	43
810 283	18	18	15	21	23	19	43	45	41
810 139	18	18	18	21	23	21	43	45	43
810 306	18	22	18	24	27	24	46	50	46
810 320	22	15	15	21	25	33	44	47	55
810 337	22	15	22	22	25	22	45	47	45
810 344	22	18	18	21	25	34	44	47	56
810 351	22	18	22	22	25	22	45	47	45
810 368	22	22	15	23	27	37	46	50	59
810 146	22	22	22	24	27	24	47	50	47
810 375	22	28	22	24	32	24	47	56	47
810 382	28	15	28	21	29	21	45	51	45
810 399	28	18	28	21	29	21	45	51	45

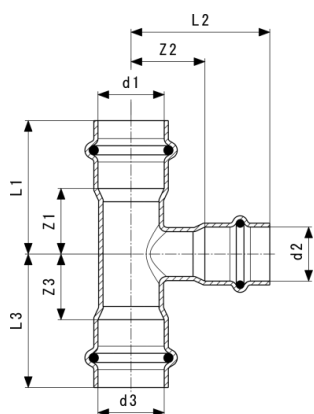

Temponox T-stuk
- roestvast staal
model 1718

artikel	d1	d2	d3	Z1	Z2	Z3	L1	L2	L3
810 405	28	22	22	23	31	41	47	54	64
810 412	28	22	28	23	31	23	47	54	47
810 153	28	28	28	28	29	28	52	53	52
810 429	35	15	35	19	33	19	45	55	45
810 436	35	18	35	19	33	19	45	55	45
810 443	35	22	35	21	34	21	47	57	47
810 450	35	28	35	27	33	27	53	57	53
810 160	35	35	35	27	27	27	53	53	53
810 467	42	15	42	19	36	19	55	58	55
810 474	42	18	42	19	36	19	55	58	55
810 481	42	22	42	19	38	19	55	61	55
810 498	42	28	42	25	37	25	61	61	61
810 504	42	35	42	25	30	25	61	56	61
810 177	42	42	42	32	32	32	68	68	68
810 511	54	15	54	18	42	18	58	42	58
810 528	54	18	54	18	42	18	58	64	58
810 535	54	22	54	18	44	18	58	67	58
810 542	54	28	54	21	43	21	61	67	61
810 559	54	35	54	25	36	25	65	62	65
810 566	54	42	54	29	38	29	69	74	69
810 184	54	54	54	39	39	39	79	79	79

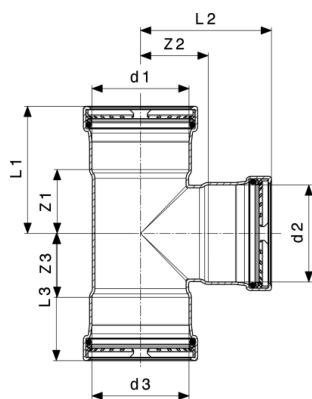

Temponox XL T-stuk
- roestvast staal
model 1718XL

artikel	d1	d2	d3	Z1	Z2	Z3	L1	L2	L3
810 672	76,1	28	76,1	27	47	27	77	71	77
810 689	76,1	35	76,1	30	48	30	80	74	80
810 696	76,1	42	76,1	34	50	34	84	86	84
810 702	76,1	54	76,1	40	50	40	90	91	90
810 207	76,1	76,1	76,1	51	54	51	101	104	101
810 726	88,9	28	88,9	27	54	27	77	78	77
810 733	88,9	35	88,9	30	54	30	80	81	80
810 740	88,9	42	88,9	34	56	34	84	92	84
810 757	88,9	54	88,9	40	57	40	90	97	90
810 771	88,9	76,1	88,9	51	61	51	101	111	101
810 214	88,9	88,9	88,9	57	60	57	107	110	107
810 788	108,0	28	108,0	27	63	27	87	87	87
810 795	108,0	35	108,0	30	64	30	90	90	90
810 801	108,0	42	108,0	34	66	34	94	102	94
810 818	108,0	54	108,0	40	67	40	100	107	100
810 832	108,0	76,1	108,0	51	71	51	111	121	111
810 849	108,0	88,9	108,0	57	70	57	117	120	117
810 221	108,0	108,0	108,0	67	70	67	127	130	127

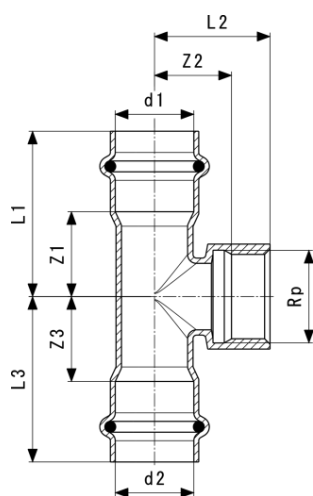

Temponox T-stuk
- roestvast staal
model 1717.2

artikel	d1	Rp	d2	Z1	Z2	Z3	L1	L2	L3
810 863	15	½	15	19	19	19	41	29	41
810 870	18	½	18	21	20	21	43	30	43
810 887	22	½	22	22	22	22	45	32	45
810 894	22	¾	22	24	22	24	47	33	47
810 900	28	½	28	21	26	21	45	36	45
810 917	28	¾	28	23	26	23	47	37	47
809 072	28	1	28	28	27	28	52	40	52
809 089	35	½	35	19	29	19	45	40	45
809 096	35	¾	35	19	30	19	45	41	45
809 102	42	½	42	19	33	19	55	43	55
809 119	42	¾	42	19	33	19	55	44	55
809 126	54	½	54	18	39	18	58	49	58
809 133	54	¾	54	18	39	18	58	50	58
809 140	54	1	54	21	41	21	61	53	61

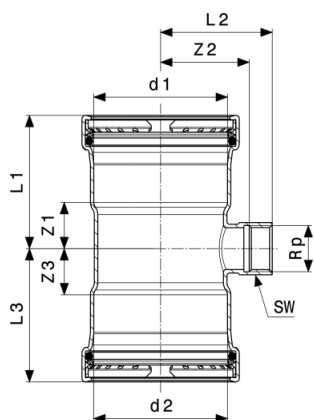

Temponox XL T-stuk
- roestvast staal
model 1717.2XL

artikel	d1	Rp	d2	Z1	Z2	Z3	L1	L2	L3	SW
810 962	76,1	¾	76,1	24	51	24	74	62	74	30
810 979	88,9	¾	88,9	24	58	24	74	69	74	30
810 986	108,0	¾	108,0	24	67	24	84	78	84	30

SW = Sleutelwijdte

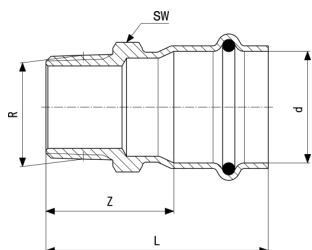

Temponox overgangsstuk
- roestvast staal
model 1711

artikel	d	R	Z	L	SW
811 501	15	⅝	28	50	19
811 488	15	½	31	53	22
811 495	15	¾	34	56	27
811 518	18	½	30	52	22
811 525	18	¾	33	55	27
811 532	22	½	31	54	22
811 549	22	¾	33	56	27
811 556	22	1	37	60	34
811 563	28	½	32	56	30
811 570	28	¾	33	57	30
811 587	28	1	36	60	34
811 594	28	1¼	42	66	43
811 600	35	1	37	64	36

SW = Sleutelwijdte

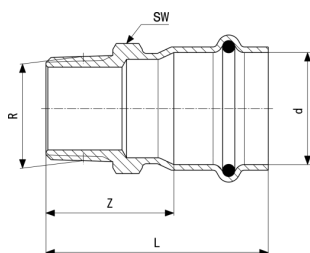

Temponox overgangsstuk
- roestvast staal
model 1711

artikel	d	R	Z	L	SW
811 617	35	1¼	43	69	43
811 624	35	1½	43	69	50
811 631	42	1¼	45	81	43
811 648	42	1½	45	81	50
811 655	54	2	49	89	62

SW = Sleutelwijdte

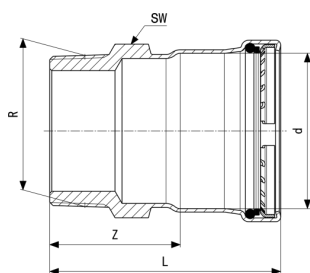

Temponox XL overgangsstuk
- roestvast staal
model 1711XL

artikel	d	R	Z	L	SW
811 686	76,1	2½	65	115	80
811 693	88,9	3	69	119	90
811 709	108,0	4	75	135	114

SW = Sleutelwijdte

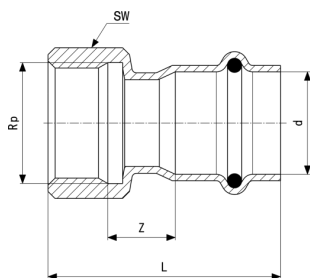

Temponox overgangsstuk
- roestvast staal
model 1712

artikel	d	Rp	Z	L	SW
811 730	15	3/8	13	44	22
811 747	15	1/2	15	49	24
811 754	15	3/4	17	50	30
811 761	18	1/2	16	48	24
811 778	18	3/4	16	49	30
811 785	22	1/2	17	50	24
811 792	22	3/4	17	51	30
811 808	22	1	18	53	36
811 815	28	3/4	16	52	30
811 822	28	1	18	54	36
811 839	35	3/4	14	52	30
811 846	35	1	17	57	36
811 853	35	1 1/4	19	60	46
811 860	42	1 1/4	21	72	46
811 877	42	1 1/2	21	72	53
811 884	54	2	24	82	65

SW = Sleutelwijdte

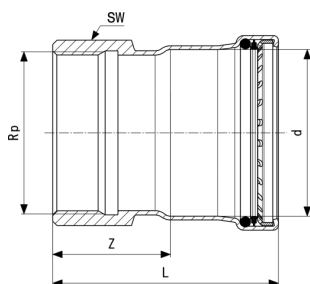

Temponox XL overgangstuk
- roestvast staal
model 1712XL

artikel	d	Rp	Z	L	SW
811 914	76,1	2½	55	105	82
811 921	88,9	3	65	115	100
811 938	108,0	4	75	135	120

SW = Sleutelwijdte

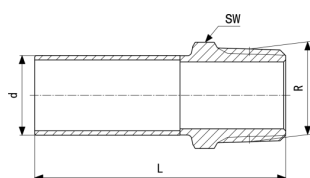

Temponox insteekstuk
- roestvast staal
model 1711.1

artikel	d	R	L	SW
810 634	15	½	58	22
810 641	18	½	57	22
812 355	22	¾	61	22
812 362	28	1	65	34

SW = Sleutelwijdte

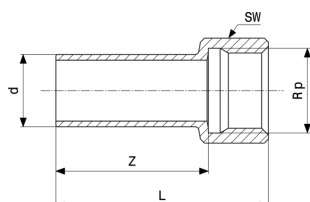

Temponox insteekstuk
- roestvast staal
model 1712.1

artikel	d	Rp	Z	L	SW
812 669	15	½	41	53	24
812 676	18	½	41	53	24
812 683	18	¾	41	55	30
812 690	22	½	42	54	24

SW = Sleutelwijdte

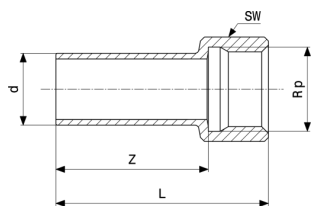

Temponox insteekstuk
- roestvast staal
model 1712.1

artikel	d	Rp	Z	L	SW
812 706	22	¾	42	55	30
812 713	28	1	44	59	36

SW = Sleutelwijdte

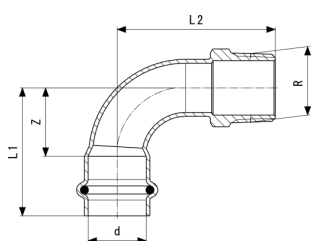

Temponox overgangstukbocht 90°
- roestvast staal
model 1714

artikel	d	R	Z	L1	L2	SW
812 409	15	½	16	38	44	22
812 416	18	½	18	40	46	22
812 423	22	½	26	49	59	22
812 430	22	¾	26	49	61	27
812 447	28	1	34	58	76	22
812 454	35	1¼	39	66	78	43
812 461	42	1½	51	87	102	50
812 478	54	2	95	135	121	62

SW = Sleutelwijdte

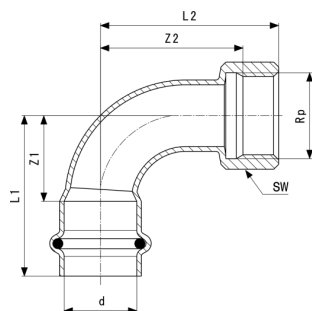

Temponox overgangsstukbocht 90°
- roestvast staal
model 1714.5

artikel	d	Rp	Z1	Z2	L1	L2	SW
812 508	15	½	16	29	38	39	24
812 515	18	½	18	32	40	42	24
812 522	22	½	26	44	49	54	24
812 539	22	¾	26	44	49	55	30
812 546	28	1	34	58	58	70	36

SW = Sleutelwijdte

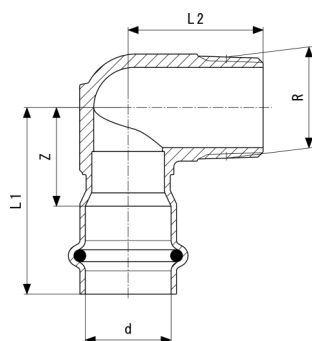

Temponox overgangsstukknie 90°
- roestvast staal
model 1714.1

artikel	d	R	Z	L1	L2
811 013	15	¾	24	46	29
811 020	15	½	24	46	29
811 037	18	½	24	46	30
811 044	22	¾	26	49	35
811 051	28	1	32	56	41

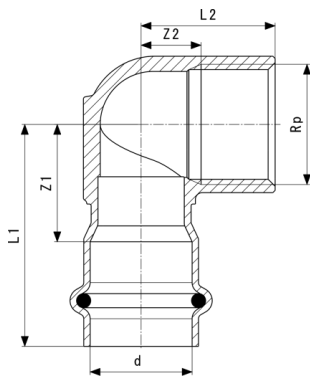

Temponox overgangsstukkie 90°
- roestvast staal
model 1714.2

artikel	d	Z1	Z2	L1	L2
811 075	15	24	11	46	26
811 082	22	24	13	47	28
811 099	22	26	13	49	30
811 105	28	24	15	48	30
811 112	28	26	16	50	32
811 129	28	32	16	56	36

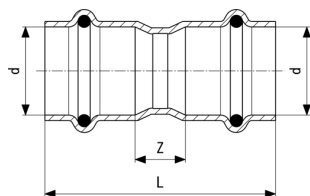

Temponox sok
- roestvast staal
model 1715

artikel	d	Z	L
809 065	15	12	56
808 983	18	11	55
808 990	22	13	59
809 003	28	12	60
809 010	35	12	64
809 027	42	12	85
809 034	54	12	93

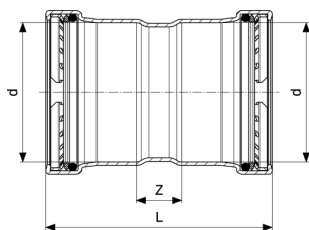

Temponox XL sok
- roestvast staal
model 1715XL

artikel	d	Z	L
809 157	76,1	25	125
809 164	88,9	25	125
809 171	108,0	25	145

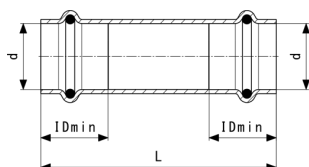

Temponox schuifsok
- roestvast staal
model 1715.5

artikel	d	IDmin	L
809 195	15	22	81
809 201	18	22	81
809 225	22	23	81
809 232	28	24	96
809 249	35	26	106
809 256	42	36	121
809 263	54	40	136

IDmin = Minimale insteekdiepte

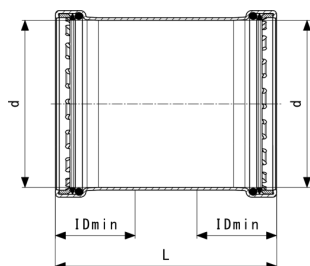

Temponox XL schuifsok
- roestvast staal
model 1715.5XL

artikel	d	IDmin	L
809 287	76,1	50	125
809 294	88,9	50	125
809 300	108,0	60	145

IDmin = Minimale insteekdiepte

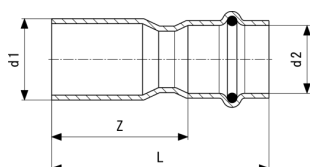

Temponox reductiestuk
- roestvast staal
model 1715.1

artikel	d1	d2	Z	L	Z*	L*
809 331	18	15	36	58	30	52
809 355	22	15	35	57		
809 362	22	18	37	59		
809 379	28	15	50	72		
809 386	28	18	47	69		
809 393	28	22	42	65		
809 409	35	15	56	78		
809 416	35	22	51	74		
809 423	35	28	43	67		
809 430	42	22	65	88		
809 447	42	28	65	89		
809 454	42	35	54	80		
809 461	54	22	80	103		
809 478	54	28	75	99		
809 485	54	35	71	97		
809 492	54	42	65	101		

Z* = Z-maten van de vorige versie

L* = Lengte van de eerdere versie

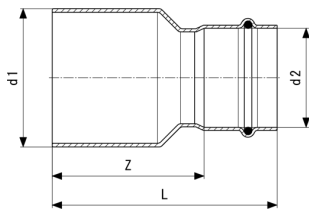

Temponox XL reductiestuk
- roestvast staal
model 1715.1XL

artikel	d1	d2	Z	L
809 515	76,1	35	91	117
809 522	76,1	42	89	125
809 539	76,1	54	84	124
809 553	88,9	54	90	130
809 577	88,9	76,1	81	131
809 584	108,0	54	109	149
809 607	108,0	76,1	102	152
809 614	108,0	88,9	94	144

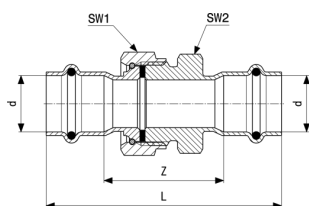

Temponox schroefkoppeling
- roestvast staal
model 1760

artikel	d	Z	L	SW1	SW2
812 232	15	42	86	27	30
812 249	18	41	85	30	27
812 256	22	48	94	37	36
812 263	28	53	101	46	46
812 270	35	58	111	53	50
810 597	42	64	136	60	55
810 603	54	71	152	78	70

SW = Sleutelwijdte

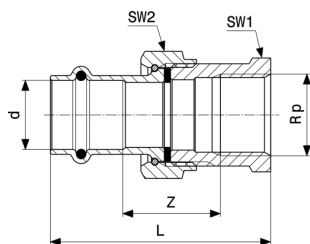

Temponox overgangsschroefkoppeling
- roestvast staal
model 1762

artikel	d	Rp	Z	L	SW1	SW2
812 140	15	½	29	66	27	30
812 157	18	½	28	65	27	30
812 164	22	¾	40	79	31	30
812 171	22	1	39	81	37	40
812 188	28	1	48	91	40	37
812 195	35	1¼	36	83	50	53
812 201	42	1½	41	98	55	60
812 218	54	2	30	96	66	78

SW = Sleutelwijdte

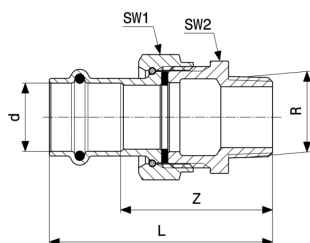

Temponox overgangsschroefkoppeling
- roestvast staal
model 1765

artikel	d	R	Z	L	SW1	SW2
812 065	15	½	46	68	30	27
812 072	18	¾	47	69	30	27
812 089	22	¾	54	77	30	27
812 096	22	1	54	77	37	34
812 102	28	1	63	87	37	34
812 119	35	1¼	63	89	53	50
812 126	42	1½	65	101	60	55
812 133	54	2	78	118	78	72

SW = Sleutelwijdte

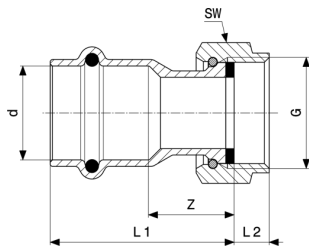

Temponox schroefkoppeling
- roestvast staal
model 1763

artikel	d	G	Z	L1	L2	SW
811 280	15	½	21	43	7	24
811 297	15	¾	15	37	9	30
811 303	15	1	15	37	8	37
811 310	18	¾	15	37	8	30
811 327	18	1	15	37	8	37
811 334	22	¾	22	45	8	30
811 341	22	1	16	39	8	37
811 358	22	1¼	18	41	10	46
811 365	22	1½	23	46	10	53
811 372	28	1	25	49	8	37
811 389	28	1¼	18	42	10	46
811 396	28	1½	23	47	10	52
811 402	35	1½	18	44	10	53
811 419	35	2	23	49	14	66
811 426	42	1¾	22	58	11	60
811 433	42	2	24	61	14	66
811 440	54	2¾	24	64	13	78
811 457	54	2½	25	66	16	84

SW = Sleutelwijdte

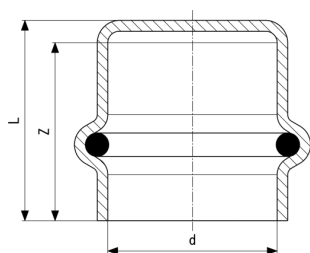

Temponox kap
- roestvast staal
model 1756

artikel	d	Z	L
811 952	15	23	26
811 969	18	23	26
811 976	22	24	27
811 983	28	25	28
811 990	35	27	31
812 003	42	36	41
812 010	54	40	44

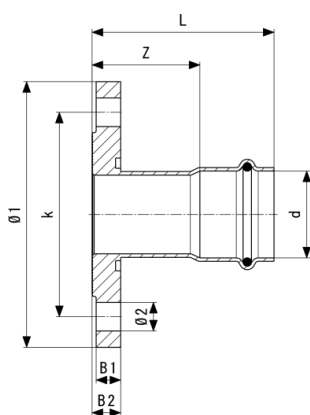

Temponox flensovergangsstuk
- roestvast staal
model 1759

artikel	DN	d	Z	L	B1	B2	k	Ø1	Ø2
811 136	32	35	44	70	16	18	100	140	18
811 143	40	42	57	93	16	19	110	150	18
811 150	50	54	56	97	16	18	125	165	18

k = Boutdiameter-Ø

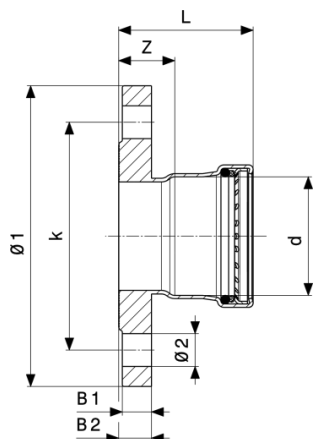

Temponox XL flensovergangsstuk
- roestvast staal
model 1759XL

artikel	DN	d	Z	L	B1	B2	Ø1	Ø2	n	k
811 174	65	76,1	29	79	15	17	180	18	8	145
811 181	80	88,9	31	81	17	19	200	18	8	160
811 198	100	108,0	31	91	17	19	220	18	8	180

n = Aantal gaten

k = Boutdiameter-Ø

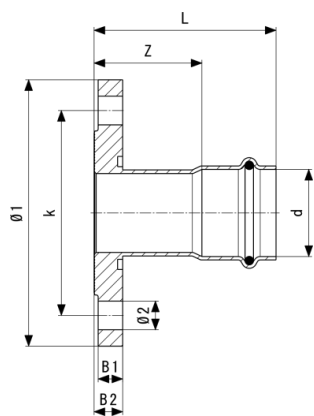

Temponox flensovergangsstuk
- roestvast staal
model 1759.1

artikel	DN	d	Z	L	B1	B2	k	Ø1	Ø2
811 204	32	35	40	66	12	14	90	120	14
811 211	40	42	53	89	12	14	100	130	14
811 228	50	54	53	93	12	14	110	140	14

k = Boutdiameter-Ø

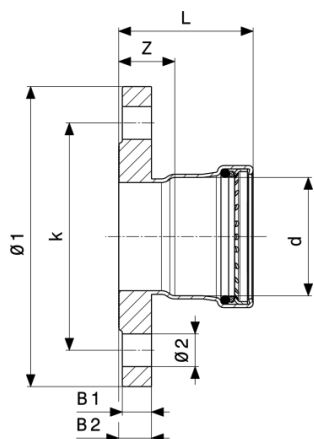

Temponox XL flensovergangsstuk
- roestvast staal
model 1759.1XL

artikel	DN	d	Z	L	B1	B2	Ø1	Ø2	n	k
811 259	65	76,1	26	76	12	14	160	14	4	130
811 266	80	88,9	28	78	14	16	190	18	4	150
811 273	100	108,0	28	88	14	16	210	18	4	170

n = Aantal gaten

k = Boutdiameter-Ø

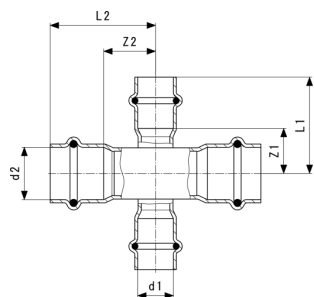

Temponox kruisstuk
- roestvast staal
model 1748

artikel	d1	d2	Z1	Z2	L1	L2
812 553	18	15	19	21	41	43
812 560	22	15	19	22	41	45
812 577	28	15	19	21	41	45

Impressie

Viega Nederland BV

Amsterdamsestraatweg 45-G
1411 AX Naarden

Postbus 5170
1410 AD Naarden

Kamer van Koophandel Gooi en Eemland nr. 32088642
BTW nr. NL810182713B01

Contact persoon:
Dhr. C.J.A.A. Jongen (directeur)

Bij het Submittal Package gaat het om vrijblijvende informatie die aan u ter beschikking wordt gesteld. Alle inhoud van dit Submittal Package wordt met veel zorg samengesteld. Toch kunnen wij de actualiteit, juistheid en volledigheid van de informatie niet garanderen. Het Submittal Package wordt bij een bestelling geen onderdeel van de overeenkomst.