

**Profipress**

oddaja paketa



**viega**

# kazalo

1	Opis skupine izdelkov	3
2	Področja uporabe	5
3	Dovoljene cevi	8
4	Certifikati	9
5	Z-mere	14
6	Kolofon	86

## Opis skupine izdelkov

Pretočno optimiziran sistem fittingov za hladno stiskanje iz bakra (99,9 % Cu-DHP), rdeče ali silicijeve litine za bakrene cevi. Fitingi za hladno stiskanje imajo valjasto vodilo cevi za zaščito tesnilnega elementa. Fitingi za hladno stiskanje od dimenzije d64,0 imajo zarezni obroč iz nerjavnega jekla, da se zagotovi mehanska obremenljivost spoja. Zatisna sila deluje pred in za sedežem tesnilnega elementa. Primerno za nadometno in podometno montažo dvizhnih in etažnih inštalacij.

### Oznaka

Proizvajalec, dimenzija cevi, šarža, oznake dovoljenj (DVGW), zelena pika na koncu stiskalnega dela, oranžna nalepka, ki jo je mogoče odstraniti kot indikator hladnega stiskanja, od d64,0

### Fiting za hladno stiskanje z varnostnim profilom SC-Contur

Pomotoma nestisnjeni spoji postanejo pri preverjanju tesnosti takoj opazni.

Viega zagotavlja zaznavanje nestisnjenih hladnih spojev v naslednjih tlačnih območjih:

min. tlak vode: 0,1 MPa / 100 kPa / 1 bar / 14,5 PSI

max. tlak vode: 0,65 MPa / 650 kPa / 6,5 bar / 94,3 PSI

min. tlak zraka: 22 hPa / 2,2 kPa / 22 mbar / 0,3 PSI

max. tlak zraka: 0,3 MPa / 300 kPa / 3 bar / 43,5 PSI

### Tesnilni elementi

EPDM (etilen-propilen-dienski kavčuk), črn, predhodno nameščen

### Opomba

Tesnilni materiali sistema fittingov za hladno stiskanje so izpostavljeni termičnemu staranju, ki zavisi od temperature medija in obratovalnega časa.

Višja kot je temperatura medija, hitreje nastopi termično staranje tesnilnega materiala.

V primeru posebnih obratovalnih pogojev, npr. v industrijskih sistemih za vračanje toplote je potrebno specifikacije proizvajalca naprave primerjati s specifikacijami cevne sistema za hladno stiskanje.

Pred uporabo fittingov za hladno stiskanje izven navedenih področij uporabe ali če dvomite v pravilno izbiro materiala, kontaktirajte podjetje Viega.

### Dimenzije

d12–108,0, razpoložljivost velikosti v skladu z nacionalnimi pravilniki

### Orodja

Funkcionalna varnost Viega sistemov za hladno stiskanje je v prvi vrsti odvisna od brezhibnega stanja uporabljenih orodij za hladno stiskanje. Za izvedbo Viega spojev s hladnim stiskanjem, Viega priporoča uporabo orodij za hladno stiskanje Viega. Orodja za hladno stiskanje Viega morajo redno vzdrževati pooblaščen servisni partnerji.

### Področja uporabe

Pitna voda

Ogrevanje/povezava radiatorjev

Deževnica

Komprimiran zrak, inertni plini

Razvodi hladilne vode

Uporaba v industriji

Gradnja postrojenj

### Opomba

V zvezi z uporabo sistema za druga področja uporabe in medije od navedenih se je treba posvetovati s podjetjem Viega! Za podrobne informacije o uporabah, omejitvah ter nacionalnih standardih in smernicah glejte informacije o izdelku, bodisi natisnjene bodisi na spletni strani Viega.

**Opomba – standardi in dovoljenja**

Fitingi za hladno stiskanje preverjeni po delovnem listu združenja DVGW W 534 z znakom opravljenega preizkusa DVGW.

Odobritev za d12–108,0 po DVGW reg. št. DW-8511BQ0586.

Fitingi za hladno stiskanje primerni za bakrene cevi po DIN EN 1057 (R290, trde za sprinkler sistem) in po delovnem listu DVGW GW 392.

Pri uporabi v ogrevalnih sistemih upoštevajte Smernico VDI 2035 in DIN EN 12828.

**Opomba – meje uporabe pri pitni vodi**

Sistem fittingov za hladno stiskanje Profipress je primeren za izvedbo inštalacij za pitno vodo v skladu z DIN 1988-200 in EN 806-2 ter ob upoštevanju izbire materiala v skladu z DIN EN 12502-1 in osnovo za ocenjevanje kovinskih materialov v kontaktu s pitno vodo UBA (nemška zvezna agencija za okolje). Pri uporabi na drugih področjih uporabe ali če niste prepričani o pravilni izbiri materiala, se obrnite na podjetje Viega. Glede na možno prekoračitev mejnih vrednosti bakrenih ionov v skladu z Uredbo o pitni vodi (PWO), je bakrene cevi in fittinge dovoljeno uporabiti le, če je vrednost pH  $\geq 7,4$  ali če pri vrednosti pH = 7,0–7,4 ni presežena celotna količina organskega ogljika TOC 1,5 mg/l!

**Obratovalni pogoji**

Sistem fittingov za hladno stiskanje Profipress se lahko uporablja v naslednjih delovnih pogojih:

Inštalacije pitne vode po DIN 1988-200 / DIN EN 806-2

Obratovalna temperatura max. 80 °C / 176 °F

Maksimalna temperatura 95 °C v obdobju 60 minut.

Inštalacije ogrevanja po DIN EN 12828

Obratovalna temperatura max. 105 °C / 221 °F

Sistem fittingov za hladno stiskanje Profipress je zasnovan za nazivni tlak PN 16.

**Materiali fittingov za hladno stiskanje**

Baker: 99,9 % Cu-DHP

Rdeča litina: CC499K

Silicijeva litina: CC 246E/CuSi4Zn9MnP

**Pridržujemo si pravico do sprememb in napak!**

Aktualne mere Z in mere za vgradnjo ter druge tehnične podatke najdete na spletni strani Viega in jih je treba preveriti pred nakupom, med načrtovanjem, gradnjo in uporabo. Naši izdelki se nenehno optimizirajo.

Ta opis izdelka vsebuje pomembne informacije o izbiri izdelka oz. sistema, namestitvi in zagonu ter namenski uporabi in po potrebi vzdrževalne ukrepe. Te informacije o izdelkih, njihove lastnosti in tehnike uporabe temeljijo na trenutno veljavnih standardih v Evropi (npr. EN) in/ali v Nemčiji (npr. DIN/DVGW). Nekateri odlomki v besedilu se lahko nanašajo na tehnične predpise v Evropi/Nemčiji. Za druge države, kjer ni ustreznih nacionalnih določil, velja ta dokumentacija kot priporočilo. Ustrezni nacionalni zakoni, standardi, predpisi, normativi in drugi tehnični predpisi imajo prednost pred nemškimi/evropskimi smernicami, opisanimi v tem opisu izdelka: predstavljene informacije niso zavezujoče za druge države in ozemlja ter jih je treba, kot rečeno, razumeti kot priporočilo.

# Področja uporabe

ime sistema: Profipress, tesnilni element: EPDM

področja uporabe	lastnosti	vrednosti
<b>Pitna voda</b> pH vrednost $\geq 7,4$ pH vrednost 7,0–7,4 s TOC max. 1,5 mg/l zahteve po TrinkwV Maksimalna temperatura 95 °C v obdobju 60 minut.	max. delovni tlak	1,6 MPa / 16 bar / 232,1 psi
	max. obratovalna temperatura	95 °C / 203 °F
<b>hladilna voda (zaprt obtok)</b>	max. delovni tlak	1,6 MPa / 16 bar / 232,1 psi
	min. obratovalna temperatura	-25 °C / -13 °F
	max. obratovalna temperatura	105 °C / 221 °F
<b>voda iz vodnjaka</b> zahteve po TrinkwV	max. delovni tlak	1,6 MPa / 16 bar / 232,1 psi
	max. obratovalna temperatura	80 °C / 176 °F
<b>Ogrevalne inštalacije</b> po DIN EN 12 828	max. delovni tlak	1,6 MPa / 16 bar / 232,1 psi
	max. obratovalna temperatura	105 °C / 221 °F
<b>sredstvo proti zmrzovanju</b> antifrogen N / clariant antifrogen L / clariant antifrogen sol (solarni sistemi) / clariant etilenglikol (etan-1,2-diol) propilenglikol (1,2-propandiol) tyfoxit / tyforop-chemie Tyfocor / Tyforop-Chemie	max. delovni tlak	1,6 MPa / 16 bar / 232,1 psi
	min. obratovalna temperatura	-25 °C / -13 °F
	max. obratovalna temperatura	105 °C / 221 °F
<b>komprimiran zrak</b> koncentracija olja $\leq 25 \text{ mg/m}^3$ d12–108,0	max. delovni tlak	1,6 MPa / 16 bar / 232,1 psi
	max. obratovalna temperatura	60 °C / 140 °F
<b>argon</b> d12–54	max. delovni tlak	1,6 MPa / 16 bar / 232,1 psi
	max. obratovalna temperatura	60 °C / 140 °F
<b>argon</b> d64,0–108,0	max. delovni tlak	1 MPa / 10 bar / 145 psi
	max. obratovalna temperatura	60 °C / 140 °F
<b>karbogen</b> ogljikov dioksid + kisik suh d12–54	max. delovni tlak	1,6 MPa / 16 bar / 232,1 psi
	max. obratovalna temperatura	60 °C / 140 °F
<b>karbogen</b> d64,0–108,0	max. delovni tlak	1 MPa / 10 bar / 145 psi
	max. obratovalna temperatura	60 °C / 140 °F
<b>kisik</b> ohranjati brez olja in maščobe d12–54	max. delovni tlak	1 MPa / 10 bar / 145 psi
	max. obratovalna temperatura	60 °C / 140 °F

**ime sistema:** Profipress, **tesnilni element:** EPDM

področja uporabe	lastnosti	vrednosti
<b>dušik</b> za uparjalnikom d12-54	max. delovni tlak	1,6 MPa / 16 bar / 232,1 psi
	max. obratovalna temperatura	60 °C / 140 °F
<b>dušik</b> d64,0-108,0	max. delovni tlak	1 MPa / 10 bar / 145 psi
	max. obratovalna temperatura	60 °C / 140 °F
<b>vodik</b> d12-108,0	max. delovni tlak	0,5 MPa / 5 bar / 72,5 psi
	max. obratovalna temperatura	60 °C / 140 °F
<b>ogljikov dioksid</b> suhi d12-54	max. delovni tlak	1,6 MPa / 16 bar / 232,1 psi
	max. obratovalna temperatura	60 °C / 140 °F
<b>ogljikov dioksid</b> d64,0-108,0	max. delovni tlak	1 MPa / 10 bar / 145 psi
	max. obratovalna temperatura	60 °C / 140 °F
<b>ogljikov monoksid</b> sestavni deli iz nerjavnega jekla niso dovoljeni d12-54	max. delovni tlak	1,6 MPa / 16 bar / 232,1 psi
	max. obratovalna temperatura	60 °C / 140 °F
<b>ogljikov monoksid</b> d64,0-108,0	max. delovni tlak	1 MPa / 10 bar / 145 psi
	max. obratovalna temperatura	60 °C / 140 °F
<b>grobi vakuum</b> p (absolutno) = 1hPa	max. obratovalna temperatura	70 °C / 158 °F
<b>formirni plin (suh/zaščitni plin za varjenje)</b> argon + ogljikov dioksid (primer Corgon) d12-54	max. delovni tlak	1,6 MPa / 16 bar / 232,1 psi
	max. obratovalna temperatura	60 °C / 140 °F
<b>formirni plin (suh/zaščitni plin za varjenje)</b> d64,0-108,0	max. delovni tlak	1 MPa / 10 bar / 145 psi
	max. obratovalna temperatura	60 °C / 140 °F
<b>kripton</b> d12-54	max. delovni tlak	1,6 MPa / 16 bar / 232,1 psi
	max. obratovalna temperatura	60 °C / 140 °F
<b>kripton</b> d64,0-108,0	max. delovni tlak	1 MPa / 10 bar / 145 psi
	max. obratovalna temperatura	60 °C / 140 °F
<b>neon</b> d12-54	max. delovni tlak	1,6 MPa / 16 bar / 232,1 psi
	max. obratovalna temperatura	60 °C / 140 °F
<b>neon</b> d64,0-108,0	max. delovni tlak	1 MPa / 10 bar / 145 psi
	max. obratovalna temperatura	60 °C / 140 °F
<b>kсенon</b> d12-54	max. delovni tlak	1,6 MPa / 16 bar / 232,1 psi
	max. obratovalna temperatura	60 °C / 140 °F

ime sistema: Profipress, tesnilni element: EPDM







področja uporabe	lastnosti	vrednosti
<b>kсенон</b> d64,0–108,0	max. delovni tlak	1 MPa / 10 bar / 145 psi
	max. obratovalna temperatura	60 °C / 140 °F
<b>синтетични зрак</b> d12–54	max. delovni tlak	1,6 MPa / 16 bar / 232,1 psi
	max. obratovalna temperatura	60 °C / 140 °F
<b>синтетични зрак</b> d64,0–108,0	max. delovni tlak	1 MPa / 10 bar / 145 psi
	max. obratovalna temperatura	60 °C / 140 °F
<b>etanol</b>	max. delovni tlak	1,6 MPa / 16 bar / 232,1 psi
	max. obratovalna temperatura	25 °C / 77 °F
<b>kondenzat</b> vodne pare brez nečistoč	max. delovni tlak	1,6 MPa / 16 bar / 232,1 psi
	max. obratovalna temperatura	105 °C / 221 °F
<b>acetone</b> tekoč	max. delovni tlak	0,5 MPa / 5 bar / 72,5 psi
	min. obratovalna temperatura	-10 °C / 14 °F
	max. obratovalna temperatura	40 °C / 104 °F











## Dovoljene cevi







standard	DN	zunani Ø	debelina stene
baker DIN EN 1057	10	12	0,8 1,0
	12	15	1,0
	15	18	
	20	22	
	25	28	1,0 1,5
	32	35	1,2 1,5
	40	42	
	50	54	1,5 2,0
	60	64,0	2,0
	65	76,1	
	80	88,9	
	100	108,0	2,5



















# Certifikati

Dubai	<b>Dubai Central Laboratory Department Attestation of Conformity</b> Sanpress pipe 1.4521 and 1.4401
	<b>ÖVGW certificate</b> Sanpress / Profipress
	<b>ÜA sign</b> Profipress, solder fittings, threaded fittings
	<b>ÜA sign</b> Raxinox pipes
	<b>ÜA sign</b> Sanpress, Raxofix, Maxiplus, bronze threaded fittings, solder fittings
	<b>SAI Watermark Certificate of Conformity - Level 1</b> Propress Water, Sanpress and Sanpress Inox
	<b>BCCA Certificate ATG</b> Profipress, Sanpress, Sanpress Inox
	<b>CCS Certificate of Type Approval</b> Sanpress Inox, Seapress, Profipress
SZU	<b>SZU Certificate</b> Profipress, Profipress S
AMTEC	<b>AMTEC Certificate</b> Profipress, Sanpress, Sanpress Inox, Prestabo, Megapress, Profipress G, Sanpress Inox G, Megapress G
DEKRA	<b>examination certificate</b> Piping system Sanpress/Sanpress XL

	<p><b>DVGW type examination certificate</b> Profipress (d 12 - 108)</p>
	<p><b>DVGW type examination certificate</b> Sanpress-pipe 1.4521 (d 12 - 108)</p>
	<p><b>DVGW type examination certificate</b> Sanpress with pipe 1.4401 (d 12 - 108)</p>
	<p><b>DVGW type examination certificate</b> Sanpress with pipe 1.4521 (d 12 - 108)</p>
	<p><b>DVGW type examination certificate</b> Sanpress pipe 1.4401 (d 12 - 108)</p>
	<p><b>TÜV Association Certificate</b> Profipress, Sanpress, Sanpress Inox, Prestabo (d 15 - 108), Temponox</p>
	<p><b>VdS certificate</b> Profipress (d 22 - 54)</p>
	<p><b>ETA Certificate</b> Profipress, Profipress XL, Sanpress, Sanpress XL</p>
	<p><b>ETA Certificate</b> Sanpress with pipe 1.4401 and 1.4521, (d 12-108)</p>
	<p><b>Eurofins Certificate</b> Profipress (d 12-54)</p>
	<p><b>CSTB Certificate</b> Profipress, Sanpress</p>

	<p><b>CSTB QB Certificate</b> Profipress, Sanpress</p>
	<p><b>CSTB QB Certificate</b> Profipress, Sanpress</p>
<p>Eurofins</p>	<p><b>Eurofins Certificate of sanitary conformity</b> Profipress</p>
<p>Eurofins</p>	<p><b>Eurofins Certificate of sanitary conformity</b> Sanpress</p>
<p>BSI</p>	<p><b>BSI Kitemark Certificate (BS EN 1254-7)</b> Profipress, Profipress G</p>
	<p><b>Lloyd's Register Type Approval Certificate</b> Profipress, ProPress</p>
	<p><b>Lloyd's Register Type Approval Certificate</b> Sanpress</p>
<p>EMI</p>	<p><b>EMI certificate</b> Profipress, Sanpress, Easytop, Sanpress Inox, Pexfit Pro Fosta, Smartpress, gunmetal threaded fittings</p>
<p>EMI</p>	<p><b>EMI Certificate of Constancy of Performance</b> Profipress</p>
	<p><b>IAPMO UPC-I Certificate of Listing</b> Copper, Cooper Alloy Fittings</p>
	<p><b>IAPMO UMC-I Certificate of Listing</b> Copper, Cooper Alloy Fittings</p>
	<p><b>IRS Type Approval Certificate</b> Seapress, Sanpress, Sanpress Inox, Profipress</p>

	<p><b>ICIM Hygiene certificate</b>                  Profipress, Profipress XL, Sanpress Inox, Sanpress Inox XL, Sanpress, Sanpress XL, Sanfix Fosta, Raxofix, Smartpress, gunmetal threaded fittings, soldered fittings</p>
	<p><b>RINA Type Approval Certificate</b>                  Profipress and ProPress</p>
	<p><b>Class NK Type Approval Certificate</b>                  Seapress, Seapress XL, Profipress and Sanpress Inox</p>
	<p><b>KIWA Product certificate</b>                  Profipress, Sanpress fittings</p>
	<p><b>KIWA Product certificate</b>                  Sanpress Inox pipe 1.4521 and 1.4401</p>
	<p><b>KIWA Product certificate</b>                  PE-Xc Smartloop pipe</p>
SINTEF	<p><b>SINTEF Certificate</b>                  Profipress, Profipress XL</p>
SINTEF	<p><b>SINTEF Certificate</b>                  Sanpress with pipe 1.4401 and 1.4521 (d 12-108)</p>
SINTEF	<p><b>SINTEF Certificate</b>                  Smartloop</p>
	<p><b>ITB National Technical Assessment</b>                  Profipress, Profipress XL, Profipress S</p>
	<p><b>ITB National Technical Assessment</b>                  Profipress, Sanpress</p>
	<p><b>ITB Certificate of Constancy of Performance</b>                  Profipress, Sanpress</p>

 10	<b>ITB National Technical Assessment</b> Sanpress Inox, Sanpress Inox XL, Sanpress, Sanpress XL
EITS	<b>EITS Technical Approval</b> Profipress
EITS	<b>EITS Technical Approval</b> Sanpress, Sanpress Inox
	<b>RM Type Approval Certificate</b> Profipress & Profipress XL types
 0134/05	<b>RISE Certificate</b> Profipress, Profipress XL, Profipress chromed
 0134/05	<b>RISE Certificate</b> Sanpress och Sanpress XL fittings
 0134/05	<b>RISE Certificate</b> Smartloop
	<b>SGBC Certificate</b> Profipress
IZV	<b>IZV Certifikat o Skladnosti</b> Profipress, Profipress XL
UKRCERTIFICATION	<b>LLC UKRCertification Certificate of conformity</b> Profipress
UKRCERTIFICATION	<b>LLC UKRCertification Certificate of conformity</b> Sanpress, Sanpress Inox
	<b>ABS Approval Certificate</b> Viega Metric CTS fittings Profipress, Profipress XL and Viega Imperial CTS fittings ProPress

# Z-mera

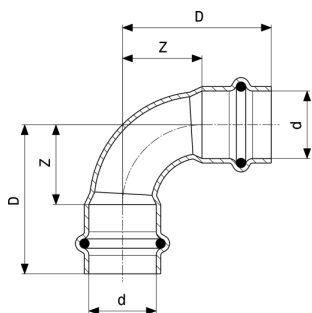

**Profipress-Lok 90°**  
- baker  
**Model 2416**

Izdelek	d	D	Z	D*	Z*
<b>291 488</b>	12	32	14		
<b>443 863</b>	14	36	17		
<b>291 501</b>	15	38	16	40	18
<b>443 870</b>	16	38	19		
<b>291 495</b>	18	40	18	44	22
<b>291 518</b>	22	49	26	42	19
<b>291 525</b>	28	55	31	58	34
<b>291 532</b>	35	59	33	68	42
<b>291 549</b>	42	69	33	86	50
<b>291 556</b>	54	95	55	105	65

D\* = dolžina predhodne različice  
Z\* = mera Z predhodne različice

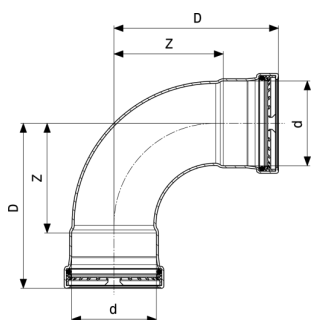

**Profipress XL-Lok 90°**  
- baker  
**Model 2416XL**

Izdelek	d	Z	D
<b>577 681</b>	64,0	84	127
<b>476 847</b>	76,1	99	149
<b>476 854</b>	88,9	115	165
<b>476 861</b>	108,0	138	198

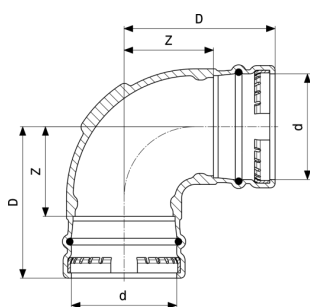

**Sanpress XL-Lok 90°**  
- rdeča litina  
**Model 2216XL**

Izdelek	d	Z	D	Z*	D*
<b>350 697</b>	76,1	44	97	68	114
<b>350 680</b>	88,9	67	120	49	102
<b>350 703</b>	108,0	77	140		

Z\* = mera Z predhodne različiče  
D\* = dolžina predhodne različiče

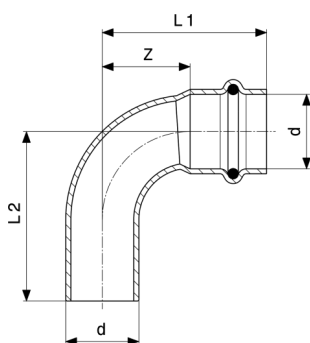

**Profipress-Lok 90°**  
- baker  
**Model 2416.1**

Izdelek	d	Z	D1	D2	Z*	D1*	D2*
<b>291 648</b>	12	14	32	34			
<b>444 099</b>	14	17	36	37			
<b>291 662</b>	15	16	38	41	18	40	41
<b>444 105</b>	16	19	38	39			
<b>291 655</b>	18	18	40	42	22	44	44
<b>291 679</b>	22	26	49	51	19	42	47
<b>291 686</b>	28	31	55	60	34	58	60
<b>291 693</b>	35	33	59	63	42	68	70
<b>291 709</b>	42	33	69	71	50	86	88
<b>291 716</b>	54	55	95	96	65	105	107

Z\* = mera Z predhodne različiče  
D\* = dolžina predhodne različiče

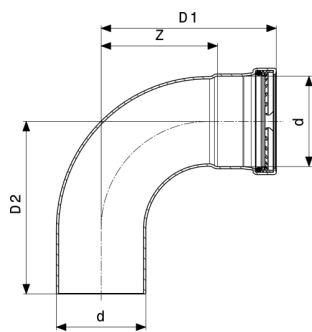

**Profipress XL-Lok 90°**  
- baker  
**Model 2416.1XL**

Izdelek	d	Z	D1	D2
<b>577 698</b>	64,0	84	127	126
<b>476 878</b>	76,1	99	149	147
<b>476 885</b>	88,9	115	165	162
<b>476 892</b>	108,0	138	198	195

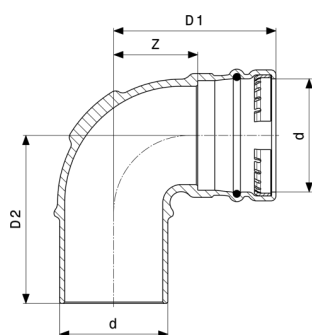

**Sanpress XL-Lok 90°**  
- rdeča litina  
**Model 2216.1XL**

Izdelek	d	Z	D1	D2	Z*	D1*	D2*
<b>353 650</b>	76,1	44	97	112	61	114	118
<b>353 667</b>	88,9	67	120	125			
<b>353 674</b>	108,0	76	140	145			

Z\* = mera Z predhodne različice  
D\* = dolžina predhodne različice



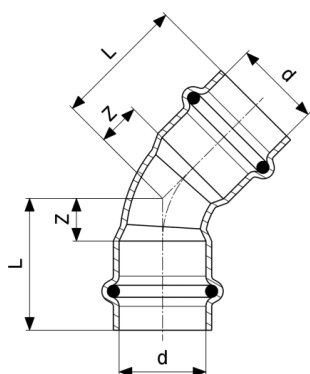

**Profipress-Lok 45°**  
- baker  
**Model 2426**

Izdelek	d	Z	D	Z*	D*
<b>292 409</b>	12	6	24		
<b>444 051</b>	14	7	26		
<b>292 348</b>	15	7	29	8	30
<b>444 068</b>	16	8	27		
<b>292 416</b>	18	7	29	9	31
<b>292 355</b>	22	11	34	9	32
<b>292 362</b>	28	12	36	14	38
<b>292 379</b>	35	15	41	17	43
<b>292 386</b>	42	17	53	21	57
<b>292 393</b>	54	22	62	27	67

Z\* = mera Z predhodne različice  
D\* = dolžina predhodne različice

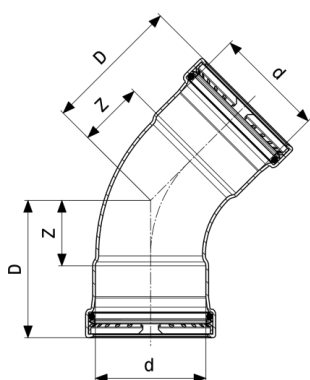

**Profipress XL-Lok 45°**  
- baker  
**Model 2426XL**

Izdelek	d	Z	D
<b>577 766</b>	64,0	39	82
<b>476 908</b>	76,1	46	96
<b>476 915</b>	88,9	52	102
<b>476 922</b>	108,0	61	121

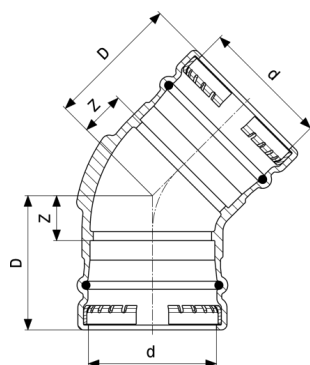

**Sanpress XL-Lok 45°**  
- rdeča litina  
**Model 2226XL**

Izdelek	d	Z	D
<b>351 342</b>	76,1	30	83
<b>351 359</b>	88,9	32	85
<b>351 366</b>	108,0	36	99

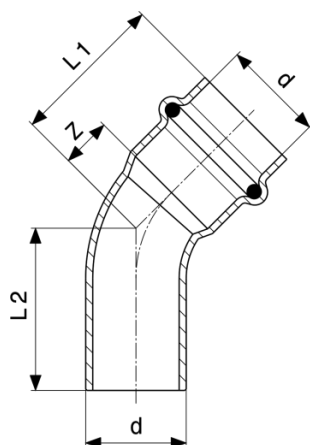

**Profipress-Lok 45°**  
- baker  
**Model 2426.1**

Izdelek	d	Z	D1	D2	Z*	D1*	D2*
<b>292 577</b>	12	6	24	26			
<b>444 112</b>	14	7	26	27			
<b>292 508</b>	15	7	29	29	8	30	31
<b>444 129</b>	16	8	27	28			
<b>292 560</b>	18	7	29	31	9	31	32
<b>292 515</b>	22	11	34	36	9	32	34
<b>292 522</b>	28	12	36	40	14	38	40
<b>292 539</b>	35	15	41	43	17	43	45
<b>292 546</b>	42	17	53	52	21	57	59
<b>292 553</b>	54	22	62	64	27	67	71

Z\* = mera Z predhodne različice  
D\* = dolžina predhodne različice

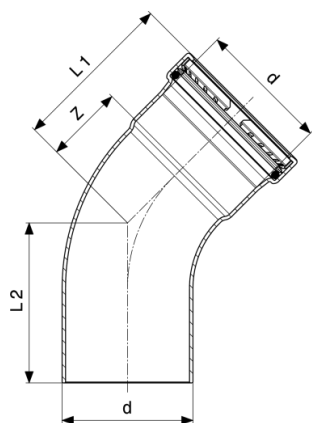

**Profipress XL-Lok 45°**  
- baker  
**Model 2426.1XL**

Izdelek	d	Z	D1	D2
<b>577 773</b>	64,0	39	82	82
<b>476 939</b>	76,1	46	96	93
<b>476 946</b>	88,9	52	102	99
<b>476 953</b>	108,0	61	121	119

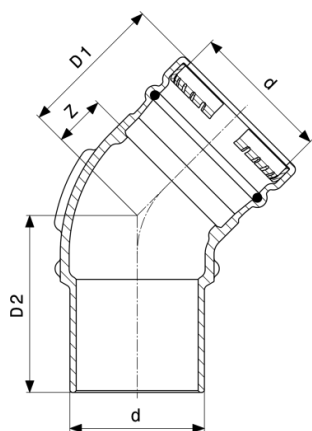

**Sanpress XL-Lok 45°**  
- rdeča litina  
**Model 2226.1XL**

Izdelek	d	Z	D1	D2
<b>353 681</b>	76,1	28	83	100
<b>353 698</b>	88,9	32	85	104
<b>353 704</b>	108,0	36	99	128

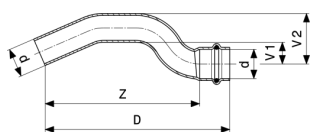

**Profipress-Izogibni lok**  
- baker  
**Model 2427**

Izdelek	d	Z	D	V1	V2
<b>322 359</b>	12	82	100	12	24
<b>322 342</b>	15	98	120	13	28
<b>322 335</b>	18	98	120	13	31
<b>322 328</b>	22	118	141	17	39

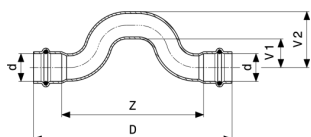

**Profipress-Izogibni lok**  
- baker  
**Model 2428**

Izdelek	d	Z	D	V1	V2
<b>352 134</b>	15	90	134	20	35
<b>352 141</b>	18	100	144	20	38
<b>352 158</b>	22	115	161	23	45

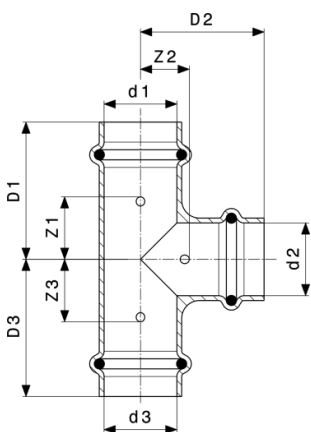

**Profipress-T-kos**  
- baker  
**Model 2418**

Izdelek	VdS	d1	d2	d3	Z1	Z2	Z3	D1	D2	D3
<b>291 884</b>		12	12	12	18	9	18	36	27	36
<b>322 717</b>		12	15	12	20	10	20	38	32	38
<b>443 900</b>		14	12	14	17	12	17	36	30	36
<b>443 887</b>		14	14	14	18	12	18	37	31	37

VdS = dovoljenje VdS

\* = ukinjeno, dobavljivo le do razprodaje zalog

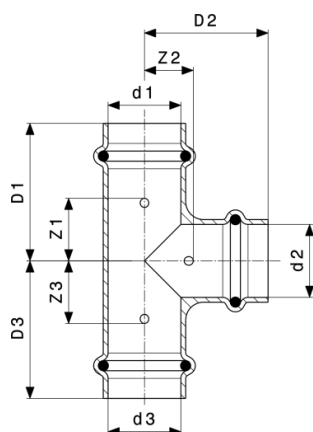

**Profipress-T-kos**  
- baker  
**Model 2418**

Izdelek	VdS	d1	d2	d3	Z1	Z2	Z3	D1	D2	D3
291 907		15	12	12	21	12	17	39	30	39
291 914		15	12	15	16	12	16	39	30	39
315 085		15	15	12	18	11	23	41	33	41
291 952		15	15	15	19	11	19	41	33	41
322 724		15	18	15	20	13	20	42	35	42
322 700		15	22	15	23	15	23	45	38	45
443 917*		16	12	14	21	12	18	40	30	36
443 924		16	14	16	18	13	18	37	32	37
443 894		16	16	16	19	13	19	38	32	38
365 073		18	12	15	17	13	21	39	31	43
324 827		18	12	18	17	13	17	39	31	39
443 931		18	14	18	18	15	18	40	34	40
291 921		18	15	15	18	13	23	41	35	45
291 938		18	15	18	18	13	18	41	35	41
443 948		18	16	18	19	15	19	41	34	41
315 009		18	18	15	20	13	25	42	35	47
291 891		18	18	18	20	13	20	42	35	42
322 694		18	22	18	23	13	23	45	36	45
324 834		22	12	22	16	15	16	39	33	39
443 955		22	14	22	17	17	17	40	36	40
292 010		22	15	15	17	15	25	41	37	47
315 078		22	15	18	17	15	22	41	37	44
292 027		22	15	22	18	15	18	41	37	41
443 962		22	16	22	18	17	18	41	36	41

VdS = dovoljenje VdS

\* = ukinjeno, dobavljivo le do razprodaje zalog

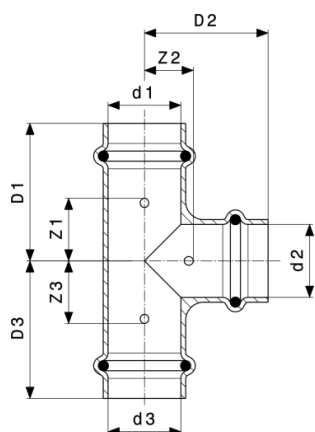

**Profipress-T-kos**  
- baker  
**Model 2418**

Izdelek	VdS	d1	d2	d3	Z1	Z2	Z3	D1	D2	D3
315 061		22	18	15	19	15	28	42	37	50
315 054		22	18	18	19	15	25	42	37	47
291 945		22	18	22	19	15	19	42	37	42
315 047		22	22	15	21	15	29	45	38	51
315 030		22	22	18	21	15	29	45	38	51
291 969	✓	22	22	22	19	15	19	42	38	42
322 687	✓	22	28	22	25	15	25	48	39	48
324 841		28	15	22	17	19	23	41	41	46
295 189		28	15	28	17	19	17	41	41	41
324 858		28	18	22	18	19	24	42	41	47
315 023		28	18	28	18	19	18	42	41	42
307 899	✓	28	22	22	21	19	27	45	42	50
295 196	✓	28	22	28	20	19	20	45	42	45
315 016	✓	28	28	22	23	19	30	48	43	53
291 976	✓	28	28	28	24	19	24	48	43	48
324 865		35	15	35	17	22	17	44	44	44
324 872		35	18	35	18	22	18	44	44	44
324 889	✓	35	22	28	19	22	29	46	45	53
292 034	✓	35	22	35	19	22	19	46	45	46
324 896	✓	35	28	28	22	22	32	49	46	56
292 041	✓	35	28	35	22	22	22	49	46	49
365 882	✓	35	35	22	26	22	40	52	48	63
365 080	✓	35	35	28	26	22	35	52	48	59
291 983	✓	35	35	35	26	22	26	52	48	52

VdS = dovoljenje VdS

\* = ukinjeno, dobavljivo le do razprodaje zalog

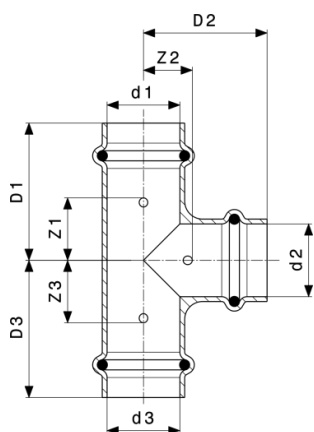

**Profipress-T-kos**  
- baker  
**Model 2418**

Izdelek	VdS	d1	d2	d3	Z1	Z2	Z3	D1	D2	D3
<b>324 902</b>	✓	42	22	42	17	29	17	53	52	53
<b>292 058</b>	✓	42	28	42	19	29	19	55	53	55
<b>292 065</b>	✓	42	35	42	22	29	22	58	55	58
<b>291 990</b>	✓	42	42	42	29	29	29	65	65	65
<b>324 919</b>	✓	54	22	54	19	35	19	60	58	60
<b>324 926</b>	✓	54	28	54	22	35	22	63	59	63
<b>324 933</b>	✓	54	35	54	26	35	26	67	61	67
<b>292 072</b>	✓	54	42	54	29	35	29	69	71	69
<b>292 003</b>	✓	54	54	54	35	35	35	75	75	75

VdS = dovoljenje VdS

\* = ukinjeno, dobavljivo le do razprodaje zalog

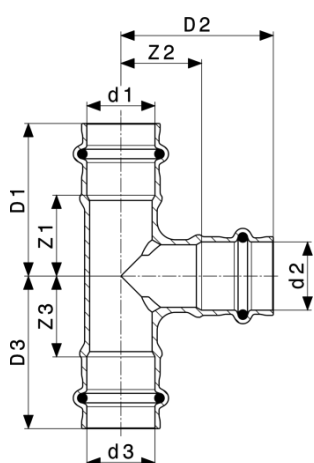

**Sanpress-T-kos**  
- rdeča ali silicijeva litina  
**Model 2218**

Izdelek	d1	d2	d3	Z1	Z2	Z3	D1	D2	D3
<b>314 132</b>	28	28	15	29	29	27	52	52	49
<b>314 163</b>	28	28	18	29	29	27	52	52	49

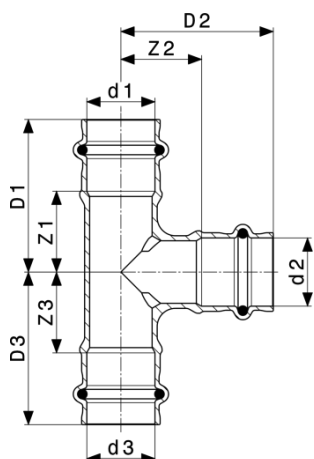

**Sanpress-T-kos**  
- rdeča ali silicijeva litina  
**Model 2218**

Izdelek	d1	d2	d3	Z1	Z2	Z3	D1	D2	D3
<b>314 224</b>	42	15	42	23	35	23	59	57	59
<b>283 551</b>	42	35	35	29	37	31	65	62	57
<b>187 279</b>	54	42	42	34	39	37	70	75	77

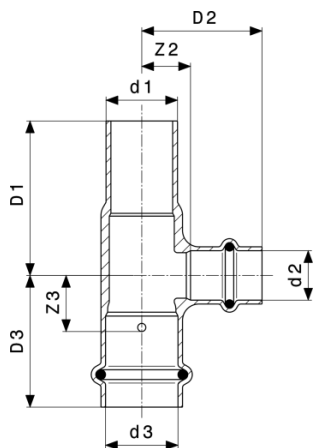

**Profipress-T-kos**  
- baker  
**Model 2418.1**

Izdelek	d1	d2	d3	Z2	Z3	D1	D2	D3
<b>477 356</b>	22	15	22	15	17	48	37	41



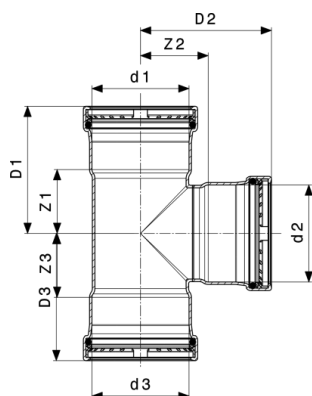

**Profipress XL-T-kos**  
- baker  
**Model 2418XL**

lzdelek	d1	d2	d3	Z1	Z2	Z3	D1	D2	D3
<b>577 735</b>	64,0	35	64,0	32	42	32	75	69	75
<b>577 742</b>	64,0	42	64,0	35	43	35	78	79	78
<b>577 759</b>	64,0	54	64,0	41	42	41	84	82	84
<b>577 728</b>	64,0	64,0	64,0	46	47	46	89	90	89
<b>476 977</b>	76,1	54	76,1	40	48	40	90	89	90
<b>476 960</b>	76,1	76,1	76,1	51	54	51	101	104	101
<b>476 991</b>	88,9	54	88,9	40	55	40	90	96	90
<b>477 004</b>	88,9	76,1	88,9	51	61	51	101	111	101
<b>476 984</b>	88,9	88,9	88,9	57	61	57	107	111	107
<b>477 028</b>	108,0	54	108,0	41	66	41	101	106	101
<b>477 035</b>	108,0	76,1	108,0	52	71	52	112	121	112
<b>477 042</b>	108,0	88,9	108,0	58	71	58	118	121	118
<b>477 011</b>	108,0	108,0	108,0	68	72	68	128	132	128

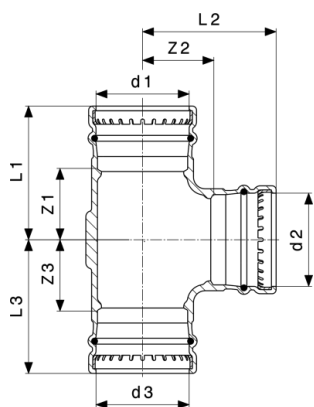

**Sanpress XL-T-kos**  
- rdeča litina  
**Model 2218XL**

Izdelek	d1	d2	d3	Z1	Z2	Z3	D1	D2	D3
<b>354 398</b>	76,1	54	76,1	47	65	47	100	105	100
<b>350 628</b>	76,1	76,1	76,1	61	61	61	114	114	114
<b>354 404</b>	88,9	54	88,9	46	70	46	100	110	100
<b>354 411</b>	88,9	76,1	88,9	62	67	62	115	120	115
<b>350 635</b>	88,9	88,9	88,9	67	67	67	120	120	120
<b>354 428</b>	108,0	54	108,0	47	80	47	110	120	110
<b>354 435</b>	108,0	76,1	108,0	62	77	62	125	130	125
<b>354 442</b>	108,0	88,9	108,0	67	77	67	130	130	130
<b>350 642</b>	108,0	108,0	108,0	77	77	77	140	140	140

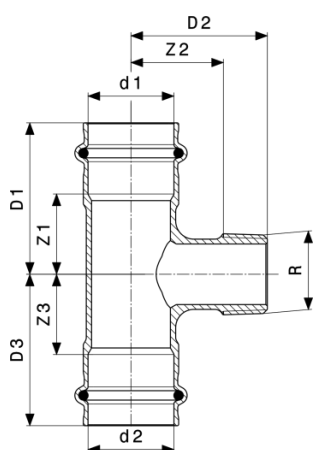

**Sanpress-T-kos**  
- rdeča ali silicijeva litina  
**Model 2217.1**

Izdelek	d1	R	d2	Z1	Z2	Z3	D1	D2	D3
<b>281 328</b>	18	3/4	18	23	26	23	45	40	45
<b>194 123</b>	22	3/4	22	27	28	27	50	42	50
<b>194 130</b>	28	3/4	28	27	31	27	50	45	50
<b>194 147</b>	35	3/4	35	25	31	25	50	45	50

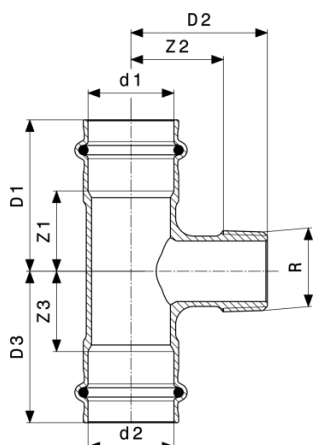

**Sanpress-T-kos**  
- rdeča ali silicijeva litina  
**Model 2217.1**

Izdelek	d1	R	d2	Z1	Z2	Z3	D1	D2	D3
<b>273 231</b>	42	¾	42	19	36	19	55	50	55
<b>197 858</b>	54	¾	54	26	41	26	66	55	66
<b>310 929</b>	54	1	54	29	46	29	69	63	69
<b>310 936</b>	54	1¼	54	32	47	32	72	66	72

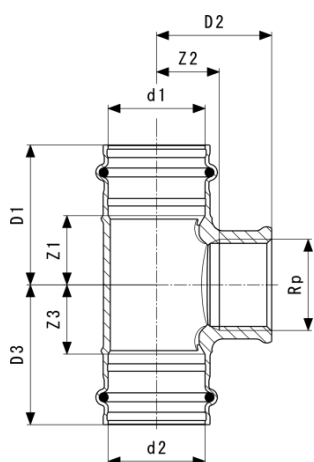

**Sanpress-T-kos**  
- rdeča ali silicijeva litina  
**Model 2217.2**

Izdelek	d1	Rp	d2	Z1	Z2	Z3	D1	D2	D3	VK
<b>290 986</b>	12	½	12	23	10	23	40	20	40	26
<b>313 951</b>	15	¾	15	21	21	21	43	21	43	21
<b>115 630</b>	15	½	15	19	11	19	41	21	41	26
<b>281 359</b>	18	½	18	18	12	18	40	22	40	26
<b>115 944</b>	22	½	22	19	13	19	42	28	42	25
<b>313 975</b>	22	¾	22	25	16	25	49	33	49	31
<b>119 768</b>	28	½	28	21	17	21	45	32	45	25

VK = velikost ključa  
Z\* = mera Z predhodne različice  
D\* = dolžina predhodne različice

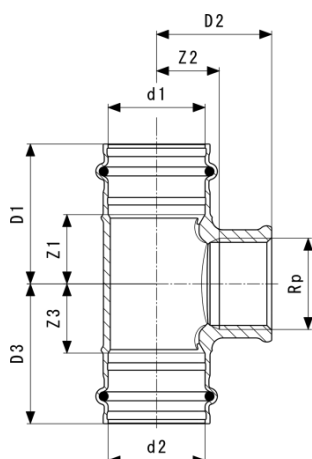

**Sanpress-T-kos**  
- rdeča ali silicijeva litina  
**Model 2217.2**

Izdelek	d1	Rp	d2	Z1	Z2	Z3	D1	D2	D3	VK
<b>313 968</b>	28	¾	28	29	19	29	52	35	53	31
<b>121 945</b>	35	½	35	19	25	19	45	35	45	26
<b>361 204</b>	35	1	35	26	23	26	51	42	51	38
<b>126 230</b>	42	½	42	19	35	19	55	50	55	28
<b>361 211</b>	42	1	42	24	31	24	60	50	60	38
<b>197 353</b>	54	½	54	26	40	26	66	55	66	28
<b>361 228</b>	54	1	54	29	47	29	69	66	69	39

Izdelek	d1	Rp	d2	Z1*	Z2*	Z3*	D1*	D2*	D3*
<b>290 986</b>	12	½	12						
<b>313 951</b>	15	¾	15						
<b>115 630</b>	15	½	15	23	9	23	45	21	45
<b>281 359</b>	18	½	18	23	25	23	45	40	45
<b>115 944</b>	22	½	22	25	28	25	49	43	49
<b>313 975</b>	22	¾	22						
<b>119 768</b>	28	½	28	25	31	25	49	46	49
<b>313 968</b>	28	¾	28						
<b>121 945</b>	35	½	35	23	34	23	49	49	49
<b>361 204</b>	35	1	35	26	23	26			
<b>126 230</b>	42	½	42						
<b>361 211</b>	42	1	42	29	37	29	65	59	65
<b>197 353</b>	54	½	54						
<b>361 228</b>	54	1	54						

VK = velikost ključa

Z\* = mera Z predhodne različice

D\* = dolžina predhodne različice

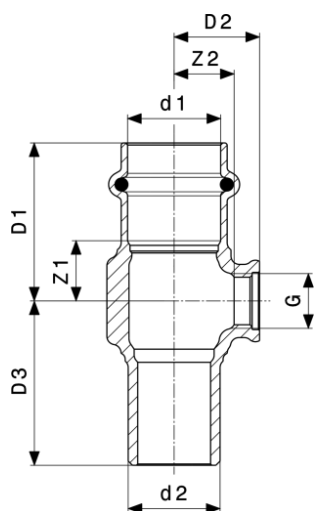

**Sanpress-T-kos**  
- rdeča ali silicijeva litina  
**Model 2217.4**

Izdelek	d1	G	d2	Z1	Z2	D1	D2	D3
<b>705 596</b>	15	¼	15	14	11	36	18	38
<b>705 602</b>	18	¼	18	14	12	36	19	38
<b>705 619</b>	22	¼	22	15	14	38	21	40
<b>705 626</b>	28	¼	28	17	17	40	24	41
<b>705 633</b>	35	¼	35	15	21	40	28	44
<b>705 640</b>	42	¼	42	16	26	52	32	61
<b>705 855</b>	54	¼	54	20	33	60	39	65

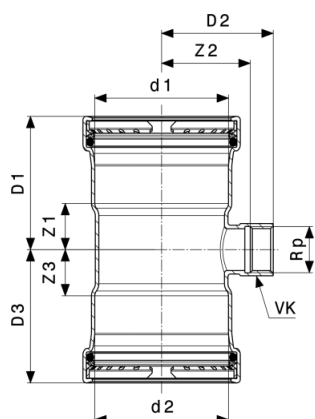

**Profipress XL-T-kos**  
- baker  
**Model 2417.2XL**

Izdelek	d1	d2	Rp	Z1	Z2	Z3	D1	D2	D3	VK
<b>577 704</b>	64,0	64,0	¾	27	46	27	70	58	70	30
<b>577 711</b>	64,0	64,0	1	32	51	32	75	63	75	38
<b>534 073</b>	76,1	76,1	¾	27	52	27	77	64	77	30
<b>534 080</b>	76,1	76,1	2	40	56	40	90	74	90	65

VK = velikost ključa

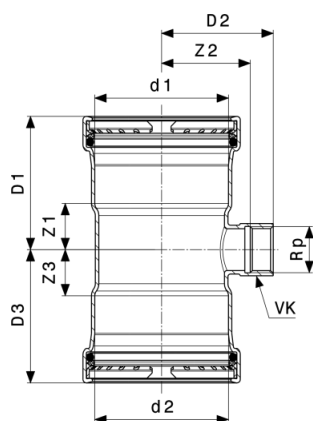

**Profipress XL-T-kos**  
- baker  
**Model 2417.2XL**

Izdelek	d1	d2	Rp	Z1	Z2	Z3	D1	D2	D3	VK
<b>534 097</b>	88,9	88,9	¾	27	58	27	77	70	77	30
<b>534 103</b>	88,9	88,9	2	40	62	40	90	80	90	65
<b>534 110</b>	108,0	108,0	¾	28	68	28	88	80	88	30
<b>534 127</b>	108,0	108,0	2	41	69	41	101	90	101	65

VK = velikost ključa

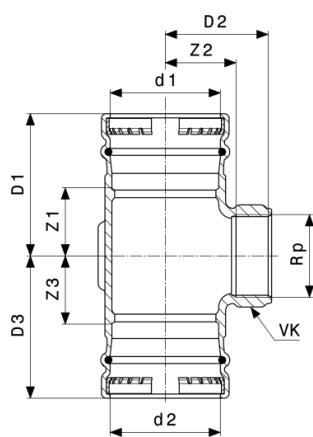

**Sanpress XL-T-kos**  
- rdeča litina  
**Model 2217.2XL**

Izdelek	d1	Rp	d2	Z1	Z2	Z3	D1	D2	D3	VK
<b>354 572</b>	76,1	¾	76,1	30	51	30	85	68	85	32
<b>351 434</b>	76,1	2	76,1	49	51	49	103	77	103	69
<b>354 589</b>	88,9	¾	88,9	32	58	32	85	74	85	32
<b>351 441</b>	88,9	2	88,9	49	57	49	103	83	103	69
<b>354 596</b>	108,0	¾	108,0	32	67	32	95	83	95	32
<b>352 097</b>	108,0	2	108,0	39	67	39	103	93	103	69

VK = velikost ključa

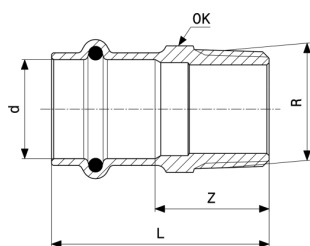

**Sanpress-Prehodni kos**  
- rdeča ali silicijeva litina  
**Model 2211**

Izdelek	d	R	Z	D	VK	Z*	D*	VK*
<b>290 771</b>	12	$\frac{3}{8}$	18	35	17	17	34	17
<b>290 764</b>	12	$\frac{1}{2}$	20	37	17	24	38	22
<b>443 689</b>	14	$\frac{3}{8}$	20	39	19	17	36	
<b>443 696</b>	14	$\frac{1}{2}$	25	44	19	22	41	22
<b>297 985</b>	15	$\frac{3}{8}$	17	39	19	20	42	
<b>105 044</b>	15	$\frac{1}{2}$	24	46	19	22	44	22
<b>287 764</b>	15	$\frac{3}{4}$	28	50	22	26	48	27
<b>443 702</b>	16	$\frac{1}{2}$	25	44	20			
<b>443 719</b>	16	$\frac{3}{4}$	27	46	22	25	44	27
<b>283 490</b>	18	$\frac{1}{2}$	23	45	22	21	43	22
<b>283 230</b>	18	$\frac{3}{4}$	27	49	22	25	47	27
<b>297 961</b>	22	$\frac{1}{2}$	25	49	27	22	45	27
<b>104 306</b>	22	$\frac{3}{4}$	26	49	27	27	50	27
<b>287 771</b>	22	1	33	56	30	32	55	34
<b>297 954</b>	28	$\frac{3}{4}$	29	52	32			
<b>106 508</b>	28	1	32	55	34			
<b>297 978</b>	28	1 $\frac{1}{4}$	35	58	34	38	62	42
<b>297 947</b>	35	1	28	53	40	30	56	
<b>110 352</b>	35	1 $\frac{1}{4}$	34	60	43	36	59	43
<b>314 651</b>	35	1 $\frac{1}{2}$	37	62	50	35	60	50
<b>297 930</b>	42	1 $\frac{1}{4}$	29	65	48			
<b>115 340</b>	42	1 $\frac{1}{2}$	30	66	50	31	67	50
<b>314 668</b>	54	1 $\frac{1}{2}$	38	78	62			
<b>195 267</b>	54	2	39	79	62			

VK = velikost ključa

Z\* = mera Z predhodne različice

D\* = dolžina predhodne različice

VK\* = predhodna različica (velikost ključa)

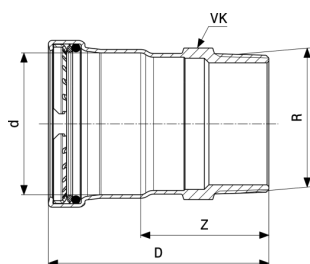

**Profipress XL-Prehodni kos**  
- baker  
**Model 2411XL**

Izdelek	d	R	Z	D	VK
<b>577 674</b>	64,0	2½	70	113	77
<b>534 134</b>	76,1	2½	70	120	77
<b>534 141</b>	88,9	3	74	124	90
<b>534 158</b>	108,0	4	86	146	115

VK = velikost ključa

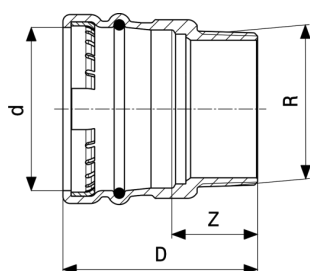

**Sanpress XL-Prehodni kos**  
- rdeča litina  
**Model 2211XL**

Izdelek	d	R	Z	D
<b>350 659</b>	76,1	2½	42	95
<b>350 666</b>	88,9	3	47	100
<b>350 673</b>	108,0	4	47	110



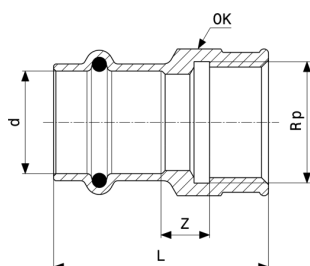

**Sanpress-Prehodni kos**  
- rdeča ali silicijeva litina  
**Model 2212**

Izdelek	d	Rp	Z	D	VK	Z*	D*	VK*
291 075	12	3/8	7	32	21			
291 068	12	1/2	7	39	26			
443 726	14	1/2	7	41	26			
298 074	15	3/8	8	37	21			
107 543	15	1/2	7	44	26	11	43	
298 098	15	3/4	10	45	31	13		
443 733	16	1/2	7	41	26			
283 483	18	1/2	4	43	26	10	42	
294 519	18	3/4	10	45	31	12		
298 067	22	1/2	6	44	26	9	42	
108 465	22	3/4	11	47	31		44	
298 128	22	1	14	52	38		49	
428 174	28	1/2	10	44	33			
298 081	28	3/4	12	47	33		46	
114 329	28	1	14	52	38			40
298 104	28	1 1/4	18	55	47			
357 542	35	3/4	10	47	40			
298 111	35	1	8	48	39	9	46	40
116 774	35	1 1/4	14	54	47	15		
298 050	42	1 1/4	12	61	47			
124 236	42	1 1/2	10	69	53	14	64	
365 097	54	1 1/2	13	72	62	11		66
195 304	54	2	15	75	66	14	75	70

VK = velikost ključa

Z\* = mera Z predhodne različice

D\* = dolžina predhodne različice

VK\* = predhodna različica (velikost ključa)

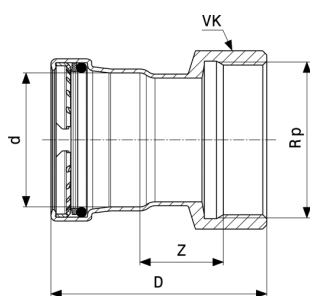

**Profipress XL-Prehodni kos**  
- baker  
**Model 2412XL**

Izdelek	d	Rp	Z	D	VK
<b>577 667</b>	64,0	2½	40	104	82

VK = velikost ključa

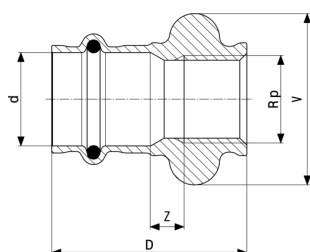

**Sanpress-Prehodni kos**  
- rdeča ali silicijeva litina  
**Model 2212.3**

Izdelek	d	Rp	Z	D	V
<b>287 016</b>	15	½	8	45	41
<b>298 913</b>	18	½	9	46	41
<b>287 009</b>	22	½	8	47	41

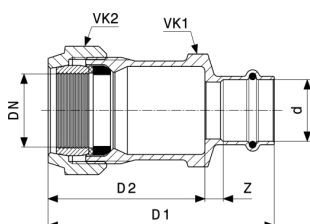

**Sanpress-Prehodni vijadni spoj**  
- rdeča ali silicijeva litina  
**Model 2215.6**

Izdelek	DN	d	Z	D1	D2	SW1	SW2
<b>588 564</b>	25	28	9	104	73	50	55
<b>588 328</b>	32	35	9	112	73	68	70

SW = velikost ključa

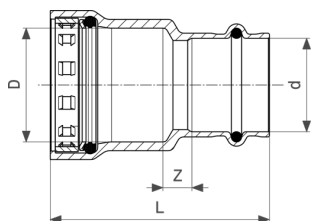

**Megapress-Prehodni kos**  
- silicijeva litina  
**Model 4213.2**

Izdelek	DN	D	d	Z	D
<b>736 255</b>	15	½	15	5	55
<b>754 679</b>	15	½	18	4	54
<b>736 279</b>	20	¾	22	5	58
<b>736 293</b>	25	1	28	9	67
<b>736 309</b>	32	1¼	35	6	78
<b>736 316</b>	40	1½	42	7	90
<b>736 323</b>	50	2	54	8	98

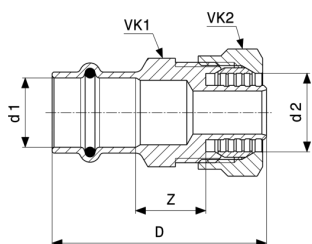

**Sanpress-Prehodni vijačni spoj**  
- rdeča litina  
**Model 2213**

Izdelek	d1	d2	D	Z	SW1	SW2
<b>288 068</b>	15	16	54	16	24	26

SW = velikost ključa

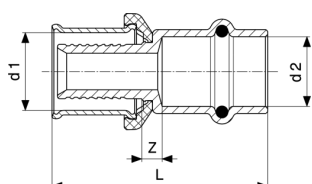

**Profipress-Prehodni kos**  
- rdeča litina  
**Model 1075.12P**

Izdelek	d1	d2	Z	D
<b>314 958</b>	14	15	6	49

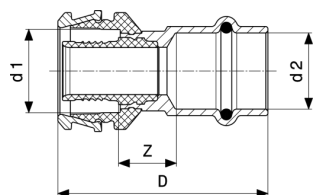

**Raxofix-Prehodni kos**  
- silicijeva litina  
**Model 5313P**

Izdelek	d1	d2	Z	D
646 707	16	15	13	50
646 714	16	18	14	51
646 721	20	15	13	50
646 738	20	18	14	51
646 745	20	22	15	53
646 752	25	22	16	59
646 769	32	28	15	59
646 776	40	28	21	71
646 783	40	35	18	70
646 790	50	35	24	76

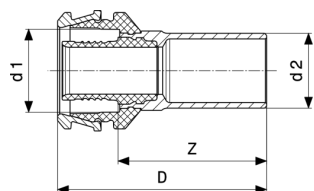

**Raxofix-Vstavni kos**  
- silicijeva litina  
**Model 5313**

Izdelek	d1	d2	Z	D
646 554	16	15	36	51
646 561	16	18	37	52
646 578	20	18	36	51
646 585	20	22	39	54
646 592	25	22	40	60
646 608	32	28	41	61
646 615	40	35	47	74
646 622	50	42	62	89

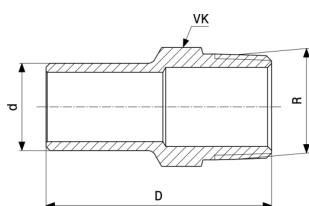

**Sanpress-Vstavni kos**  
- rdeča ali silicijeva litina  
**Model 2211.1**

Izdelek	d	R	D	VK
291 310	12	½	47	22
115 418	15	½	49	22
285 081	18	½	50	22
285 104	18	¾	56	27
119 676	22	½	53	22
116 767	22	¾	58	27
122 034	28	1	62	34
125 288	35	1¼	66	43
132 231	42	1½	78	50

VK = velikost ključa

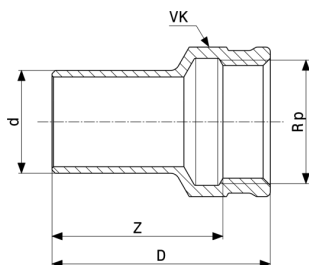

**Sanpress-Vstavni kos**  
- rdeča ali silicijeva litina  
**Model 2212.1**

Izdelek	d	Rp	Z	D	VK
291 341	12	½	31	40	25
117 733	15	½	34	44	25
287 085	18	½	34	43	25
287 108	18	¾	35	45	31
120 917	22	½	36	45	25
117 481	22	¾	37	47	31
130 954	28	¾	37	47	31
122 942	28	1	39	51	38
134 730	35	1	42	54	38
130 589	35	1¼	46	59	47
135 430	42	1½	57	70	53

VK = velikost ključa

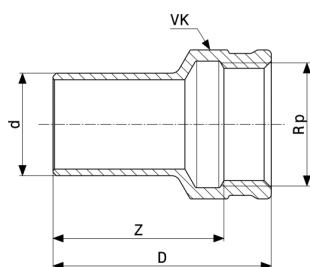

**Sanpress-Vstavni kos**  
- rdeča ali silicijeva litina  
**Model 2212.1**

Izdelek	d	Rp	Z	D	VK
<b>199 104</b>	54	2	63	80	70

VK = velikost ključa

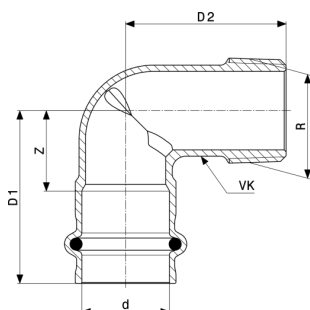

**Sanpress-Prehodni lok 90°**  
- rdeča ali silicijeva litina  
**Model 2214**

Izdelek	d	R	Z	D1	D2	VK	Z*	D1*	D2*
<b>290 863</b>	12	3/8	14	31	31	15	19	37	40
<b>290 870</b>	12	1/2	19	37	37	17	19	37	44
<b>444 006</b>	14	1/2	18	37	35	19	21	40	45
<b>314 361</b>	15	3/8	18	40	40	17	23	45	47
<b>112 950</b>	15	1/2	17	39	35	19	23	45	43
<b>443 030</b>	15	3/4	24	46	55	25	29	51	59
<b>444 013</b>	16	1/2	18	37	35	19	22	41	45
<b>281 205</b>	18	1/2	20	42	42	19	20	46	50
<b>314 354</b>	18	3/4	24	46	55	25			
<b>115 623</b>	22	3/4	21	44	41	25	28	51	59
<b>118 730</b>	28	1	35	58	58	31			72
<b>127 329</b>	35	1 1/4	33	58	58	39	48	74	88
<b>128 500</b>	42	1 1/2	29	65	60	51	20	42	42
<b>197 988</b>	54	2	43	83	80	55	70	110	120

VK = velikost ključa

Z\* = mera Z predhodne različice

D\* = dolžina predhodne različice

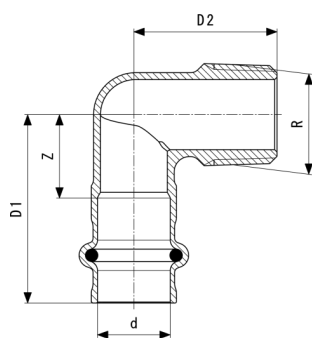

**Sanpress-Prehodno koleno 90°**  
- rdeča ali silicijeva litina  
**Model 2214.1**

Izdelek	d	R	Z	D1	D2
<b>335 281</b>	15	½	18	40	30

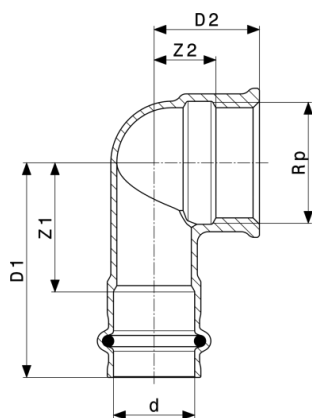

**Sanpress-Prehodno koleno 90°**  
- rdeča ali silicijeva litina  
**Model 2214.2**

Izdelek	d	Rp	Z1	Z2	D1	D2	Z1*	Z2*	D1*	D2*
<b>290 924</b>	12	¾	21	9	38	17				
<b>290 931</b>	12	½	23	10	40	20				
<b>444 020</b>	14	½	23	12	42	22				
<b>298 241</b>	15	¾	24	11	46	19				
<b>108 441</b>	15	½	22	12	44	22	24	12	46	22
<b>314 385</b>	15	¾	28	14	50	25				
<b>444 037</b>	16	½	25	13	44	22				
<b>281 236</b>	18	½	24	12	46	22				
<b>298 227</b>	18	¾	28	13	50	24				
<b>298 234</b>	22	½	29	16	52	26				
<b>283 711</b>	22	¾	29	16	52	27				
<b>314 378</b>	22	1	36	17	59	29				
<b>442 033</b>	28	½	33	23	56	32				

Z\* = mera Z predhodne različice  
D\* = dolžina predhodne različice

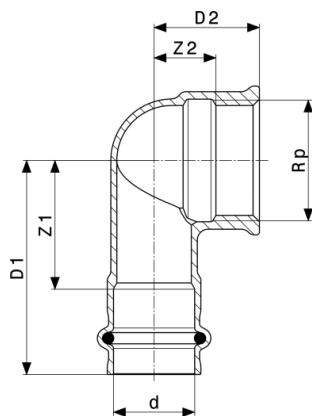

**Sanpress-Prehodno koleno 90°**  
 - rdeča ali silicijeva litina  
**Model 2214.2**

Izdelek	d	Rp	Z1	Z2	D1	D2	Z1*	Z2*	D1*	D2*
<b>446 611</b>	28	¾	35	16	58	27				
<b>283 728</b>	28	1	36	20	59	33				
<b>283 704</b>	35	1¼	41	25	66	39				
<b>299 415</b>	42	1½	41	29	77	43				
<b>299 422</b>	54	2	57	37	97	55				

Z\* = mera Z predhodne različice  
 D\* = dolžina predhodne različice

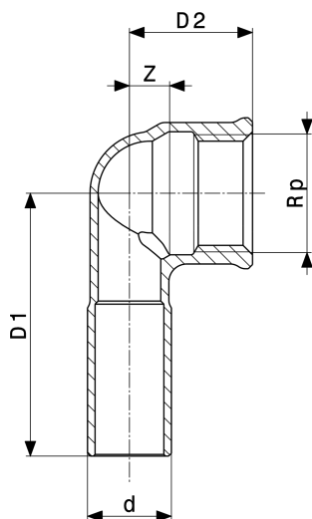

**Sanpress-Vstavno koleno 90°**  
 - rdeča ali silicijeva litina  
**Model 2214.3**

Izdelek	d	Rp	Z	D1	D2
<b>308 001</b>	15	½	12	47	22



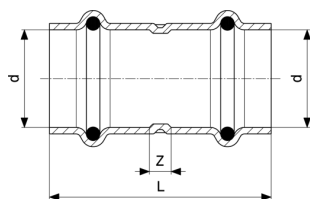

**Profipress-Spojka**  
- baker  
**Model 2415**

Izdelek	d	Z	D
<b>292 737</b>	12	3	39
<b>443 740</b>	14	3	41
<b>292 690</b>	15	3	47
<b>443 856</b>	16	3	41
<b>292 744</b>	18	5	49
<b>292 683</b>	22	5	51
<b>292 676</b>	28	4	52
<b>292 706</b>	35	4	56
<b>292 713</b>	42	4	76
<b>292 720</b>	54	4	84

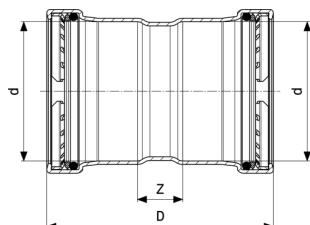

**Profipress XL-Spojka**  
- baker  
**Model 2415XL**

Izdelek	d	Z	D
<b>577 582</b>	64,0	24	110
<b>477 059</b>	76,1	25	125
<b>477 066</b>	88,9	25	125
<b>477 073</b>	108,0	27	147

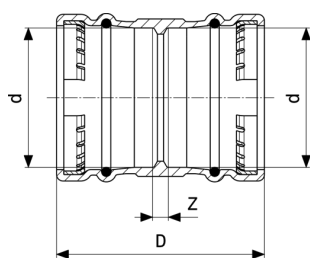

**Sanpress XL-Spojka**  
- rdeča litina  
**Model 2215XL**

Izdelek	d	Z	D
<b>350 598</b>	76,1	9	115
<b>350 604</b>	88,9	9	115
<b>350 611</b>	108,0	9	135

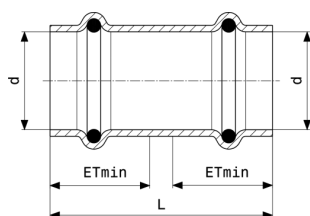

**Profipress-Drsna spojka**  
- baker  
**Model 2415.3**

Izdelek	d	D	VGnajm
<b>713 416</b>	12	39	18
<b>461 256</b>	15	47	22
<b>461 263</b>	18	49	22
<b>461 270</b>	22	51	23
<b>461 287</b>	28	52	24
<b>461 294</b>	35	56	26
<b>461 317</b>	42	76	36
<b>461 300</b>	54	84	40

VGnajm = najmanjša vtična globina

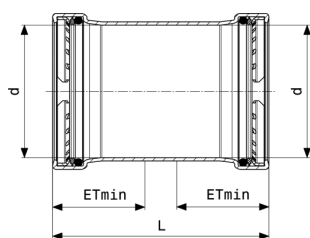

**Profipress XL-Drnsna spojka**  
- baker  
**Model 2415.5XL**

Izdelek	d	D	VGnajm
<b>577 650</b>	64,0	110	43
<b>477 080</b>	76,1	125	50
<b>477 097</b>	88,9	125	50
<b>477 103</b>	108,0	147	60

VGnajm = najmanjša vtična globina

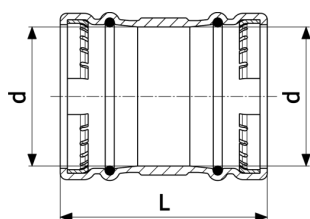

**Sanpress XL-Drnsna spojka**  
- rdeča litina  
**Model 2215.5XL**

Izdelek	d	D	VGnajm
<b>353 315</b>	76,1	115	43
<b>353 322</b>	88,9	115	43
<b>353 339</b>	108,0	135	43

VGnajm = najmanjša vtična globina

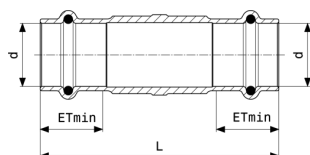

**Sanpress-Drnsna spojka**  
- rdeča ali silicijeva litina  
**Model 2215.5**

Izdelek	d	D	VGnajm
<b>119 485</b>	15	80	22
<b>287 061</b>	18	80	22
<b>119 041</b>	22	85	24
<b>122 133</b>	28	95	24
<b>124 335</b>	35	105	26
<b>131 494</b>	42	120	36

VGnajm = najmanjša vtična globina

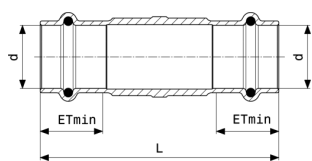

**Sanpress-Drnsna spojka**  
- rdeča ali silicijeva litina  
**Model 2215.5**

Izdelek	d	D	VGnajm
<b>216 153</b>	54	134	48

VGnajm = najmanjša vtična globina

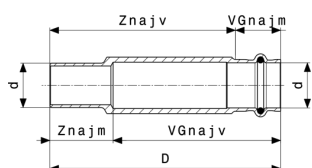

**Sanpress-Drnsna spojka**  
- rdeča ali silicijeva litina  
**Model 2215.4**

Izdelek	d	D	VGnajv	VGnajm	Znajv	Znajm
<b>588 533</b>	22	115	84	23	90	32
<b>588 540</b>	28	125	93	26	93	32
<b>588 557</b>	35	135	100	25	99	36

VGnajv = največja vtična globina

VGnajm = najmanjša vtična globina

Znajv = največja mera Z

Znajm = najmanjša mera Z

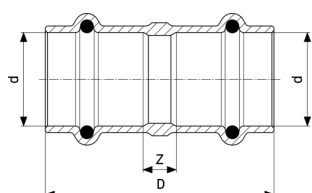

**Sanpress-Spojka**  
- rdeča litina  
**Model 9777.9**

Izdelek	d	Z	D
<b>335 946<sup>1</sup></b>	10	5	40

<sup>1</sup>) Spoj s hladnim stiskanjem d10 je treba izvesti s čeljustmi za hladno stiskanje 12.

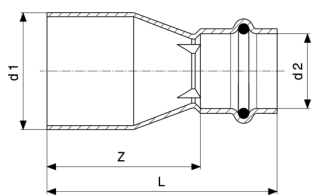

**Profipress-Reducirni kos**  
- baker  
**Model 2415.1**

Izdelek	d1	d2	Z	D
443 771	14	12	24	42
296 414	15	12	32	50
443 788	16	12	31	49
443 795	16	14	24	43
298 586	18	12	35	53
443 801	18	14	33	52
296 407	18	15	32	54
443 818	18	16	28	47
443 825	22	14	36	55
296 377	22	15	36	58
443 832	22	16	36	55
296 391	22	18	33	55
296 469	28	15	43	65
296 384	28	18	39	61
296 506	28	22	31	54
296 452	35	22	46	69
296 490	35	28	39	63
296 445	42	22	69	92
296 483	42	28	63	87
296 476	42	35	56	82
366 476	54	28	79	103
296 438	54	35	71	97
296 421	54	42	62	99

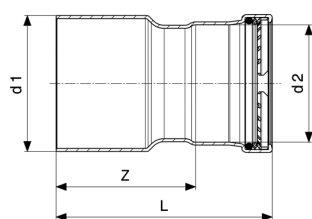

**Profipress XL-Reducirni kos**  
- baker  
**Model 2415.1XL**

Izdelek	d1	d2	Z	D
<b>577 605</b>	64,0	42	67	103
<b>577 612</b>	64,0	54	70	110
<b>477 110</b>	76,1	54	91	132
<b>587 505</b>	76,1	64,0	92	135
<b>477 127</b>	88,9	54	98	139
<b>477 134</b>	88,9	76,1	91	141
<b>477 141</b>	108,0	54	118	158
<b>477 158</b>	108,0	76,1	111	161
<b>477 165</b>	108,0	88,9	104	154

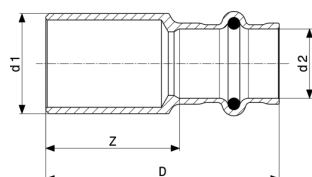

**Sanpress-Reducirni kos**  
- rdeča ali silicijeva litina  
**Model 2215.1**

Izdelek	d1	d2	Z	D	Z*	D*
<b>366 865</b>	22	12	30	47	26	43

Z\* = mera Z predhodne različice  
D\* = dolžina predhodne različice

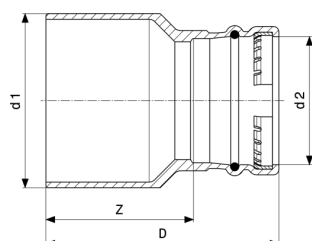

**Sanpress XL-Reducirni kos**  
- rdeča litina  
**Model 2215.1XL**

Izdelek	d1	d2	Z	D
<b>354 664</b>	76,1	54	81	121
<b>354 671</b>	88,9	54	86	126
<b>354 688</b>	88,9	76,1	72	125

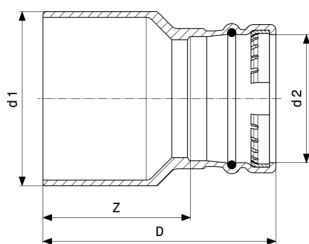

**Sanpress XL-Reducimi kos**  
- rdeča litina  
**Model 2215.1XL**

Izdelek	d1	d2	Z	D
<b>354 695</b>	108,0	54	106	146
<b>354 701</b>	108,0	76,1	92	145
<b>354 718</b>	108,0	88,9	87	140

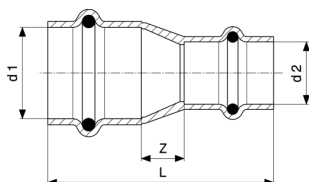

**Profipress-Reducirna spojka**  
- baker  
**Model 2415.2**

Izdelek	d1	d2	Z	D
<b>325 770</b>	15	12	8	48
<b>325 787</b>	18	15	9	53
<b>325 794</b>	22	15	11	56
<b>325 800</b>	22	18	9	54
<b>325 817</b>	28	22	11	58
<b>328 269</b>	35	28	13	63
<b>328 252</b>	42	35	13	75
<b>328 276</b>	54	42	19	95

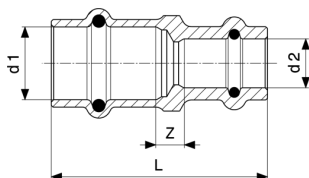

**Sanpress-Reducirna spojka**  
- rdeča litina  
**Model 9778.0**

Izdelek	d1	d2	Z	D
<b>335 953<sup>1</sup></b>	12	10	5	40

<sup>1</sup>) Spoj s hladnim stiskanjem d10 je treba izvesti s čeljustmi za hladno stiskanje 12.

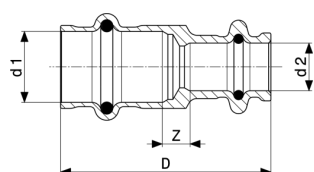

**Sanpress-Reducirna spojka**  
- rdeča litina  
**Model 9778.1**

Izdelek	d1	d2	Z	D
<b>335 960<sup>1</sup></b>	15	10	6	46

1) Spoj s hladnim stiskanjem d10 je treba izvesti s čeljustmi za hladno stiskanje 12.

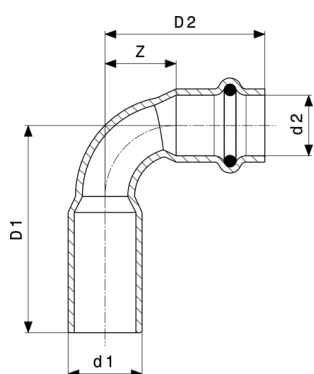

**Profipress-Reducirni lok 90°**  
- baker  
**Model 2416.2**

Izdelek	d1	d2	Z	D1	D2
<b>629 281</b>	15	12	14	32	42

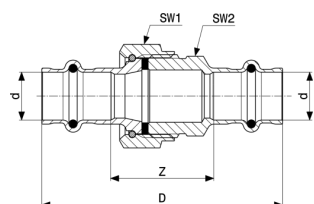

**Sanpress-Vijačni spoj**  
- rdeča ali silicijeva litina  
**Model 2260**

Izdelek	d	Z	D	SW1	SW2
<b>293 017</b>	12	30	65	24	30
<b>126 148</b>	15	33	77	24	30
<b>287 436</b>	18	36	80	24	30
<b>126 124</b>	22	42	89	31	37
<b>124 311</b>	28	48	95	40	46
<b>130 947</b>	35	49	100	45	53
<b>132 446</b>	42	49	121	50	60
<b>226 329</b>	54	49	129	70	78

SW = velikost ključa



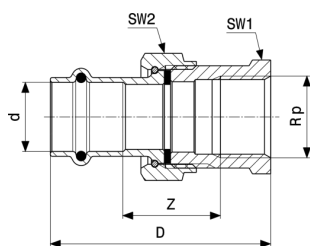

**Sanpress-Prehodni vijalni spoj**  
- rdeča ali silicijeva litina  
**Model 2262**

Izdelek	d	Rp	Z	D	SW1	SW2
293 024	12	½	23	56	27	30
131 937	15	½	26	63	27	30
133 160	15	¾	33	66	31	30
283 384	18	½	28	65	27	30
314 910	18	¾	36	68	31	30
125 318	22	¾	32	72	34	37
133 900	22	1	42	78	40	37
365 103	28	¾	23	63	32	46
128 975	28	1	33	76	44	46
138 875	35	1¼	36	83	50	53
141 745	42	1½	38	96	56	60
222 017	54	2	27	84	66	78

SW = velikost ključa

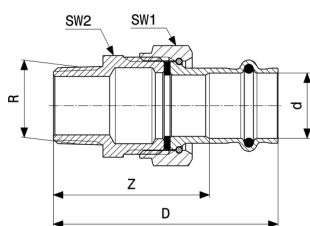

**Sanpress-Prehodni vijalni spoj**  
- rdeča ali silicijeva litina  
**Model 2265**

Izdelek	d	R	Z	D	SW1	SW2
291 372	12	⅝	40	58	30	27
291 389	12	½	44	61	30	27
120 108	15	½	46	68	30	27
140 878	15	¾	47	69	30	27
283 360	18	½	49	71	30	27
283 377	18	¾	50	72	30	27
142 674	22	½	50	74	37	34
119 133	22	¾	54	77	37	34

SW = velikost ključa

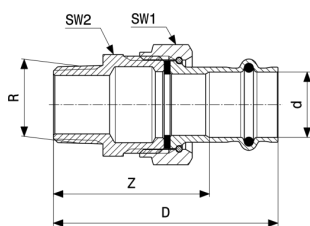

**Sanpress-Prehodni vijačni spoj**  
- rdeča ali silicijeva litina  
**Model 2265**

Izdelek	d	R	Z	D	SW1	SW2
<b>148 492</b>	22	1	54	78	37	34
<b>365 110</b>	28	¾	58	82	46	44
<b>120 047</b>	28	1	59	83	46	44
<b>128 425</b>	35	1¼	63	89	53	50
<b>135 966</b>	42	1½	69	105	60	55
<b>221 997</b>	54	2	67	107	78	70

SW = velikost ključa

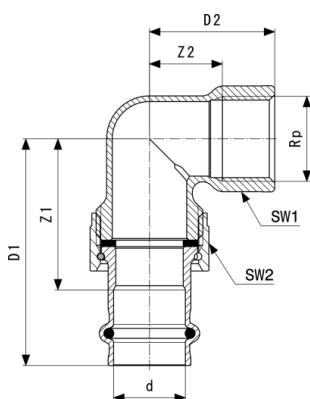

**Sanpress-Prehodni vijačni spoj 90°**  
- rdeča ali silicijeva litina  
**Model 2255**

Izdelek	d	Rp	Z1	Z2	D1	D2	SW1	SW2
<b>292 980*</b>	12	½	36	18	53	33	28	30
<b>125 660</b>	15	½	38	18	60	33	28	30
<b>283 469</b>	18	½	41	17	63	28	28	30
<b>283 452</b>	18	¾	43	22	65	33	33	36
<b>122 614</b>	22	¾	47	22	71	33	33	37
<b>132 637</b>	22	1	50	25	74	44	40	37
<b>128 159</b>	28	1	57	28	81	47	39	46
<b>132 729</b>	35	1¼	60	35	85	57	47	53
<b>139 872</b>	42	1½	72	38	108	59	55	60
<b>221 676</b>	54	2	74	43	114	69	69	78

SW = velikost ključa

\* = ukinjeno, dobavljivo le do razprodaje zalog

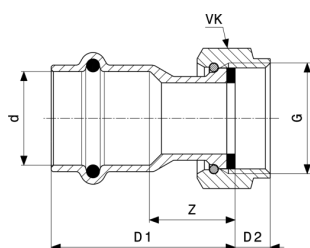

**Sanpress-Privijalo**  
- rdeča ali silicijeva litina  
**Model 2263**

Izdelek	VdS	d	G	Z	D1	D2	VK
475 956		12	3/8	17	35	7	22
380 878		12	1/2	13	31	7	24
293 611		12	3/4	10	27	9	30
476 786		14	3/8	18	37	7	22
443 849		14	1/2	15	34	7	24
444 150		14	3/4	12	31	8	30
475 963		15	3/8	19	41	7	22
380 885		15	1/2	15	37	7	24
265 663		15	3/4	12	34	8	30
305 000		15	1	11	33	8	36
424 534		15	1 1/4	14	36	12	50
444 167		16	1/2	16	35	7	24
444 174		16	3/4	12	31	8	30
283 391		18	3/4	15	37	8	30
305 017		18	1	11	33	8	36
351 502		22	3/4	21	44	8	30
265 687	✓	22	1	16	39	8	37
367 015	✓	22	1 1/4	13	37	11	50
305 260	✓	22	1 1/2	13	37	8	52
692 629		28	1	19	42	8	37
265 700	✓	28	1 1/4	18	42	10	46
305 048	✓	28	1 1/2	15	39	11	52
265 731	✓	35	1 1/2	18	44	10	53
305 024	✓	35	2	14	39	12	65
265 304	✓	42	1 3/4	22	58	11	60
305 031	✓	42	2	20	56	14	66
426 743	✓	54	2 1/4	22	62	14	72
265 328	✓	54	2 3/8	13	53	12	78

VdS = dovoljenje VdS  
VK = velikost ključa

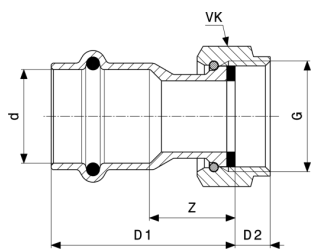

**Sanpress-Privijalo**  
- rdeča ali silicijeva litina  
**Model 2263**

Izdelek	VdS	d	G	Z	D1	D2	VK
<b>341 961</b>	✓	54	2½	17	57	16	88
<b>426 750</b>	✓	54	2¾	16	56	17	88

VdS = dovoljenje VdS  
VK = velikost ključa

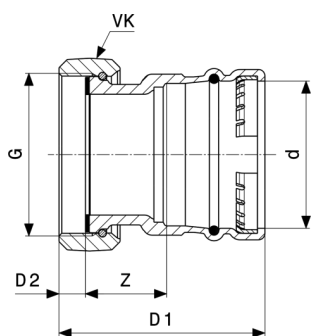

**Sanpress XL-Privijalo**  
- rdeča litina  
**Model 2263XL**

Izdelek	d	G	Z	D1	D2	VK
<b>365 127</b>	76,1	3	42	111	14	98
<b>365 134</b>	88,9	3½	42	111	14	112

VK = velikost ključa

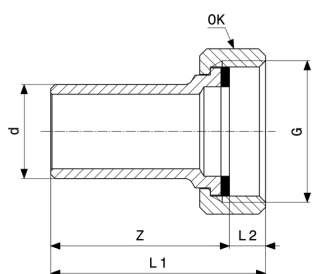

**Sanpress-Privijalo**  
- rdeča ali silicijeva litina  
**Model 2264**

Izdelek	d	G	Z	D1	D2	VK
<b>338 503</b>	15	¾	41	49	8	29
<b>338 510</b>	18	¾	41	49	8	29
<b>338 527</b>	22	1	42	51	9	36

VK = velikost ključa

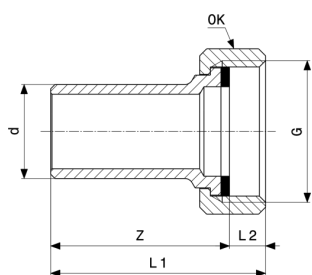

**Sanpress-Privijalo**  
- rdeča ali silicijeva litina  
**Model 2264**

Izdelek	d	G	Z	D1	D2	VK
<b>338 534</b>	28	1¼	44	53	9	46
<b>338 541</b>	35	1½	46	56	10	52
<b>338 558</b>	42	1¾	63	74	11	59
<b>338 565</b>	54	2¾	55	68	13	75

VK = velikost ključa

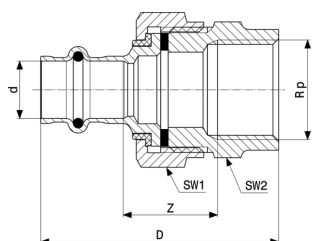

**Sanpress-Izolirni vijalni spoj**  
- rdeča ali silicijeva litina  
**Model 2267**

Izdelek	d	Rp	Z	D	SW1	SW2
<b>469 450</b>	15	½	18	55	37	34
<b>469 467</b>	15	¾	25	64	37	34
<b>469 474</b>	18	½	20	58	46	44
<b>469 481</b>	18	¾	19	58	46	44
<b>469 498</b>	22	¾	21	63	55	50
<b>469 504</b>	22	1	23	65	55	50
<b>469 511</b>	28	1	23	65	55	50
<b>469 528</b>	35	1¼	21	68	70	62
<b>469 535</b>	42	1½	19	77	73	68
<b>469 542</b>	54	2	24	90	88	83

SW = velikost ključa

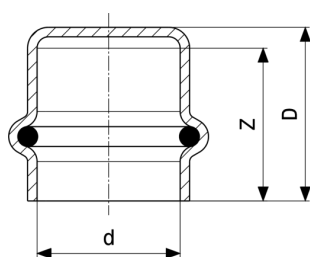

**Profipress-Kapa**  
- baker  
**Model 2456**

Izdelek	d	Z	D
<b>349 295</b>	12	20	23
<b>444 075</b>	14	21	24
<b>349 301</b>	15	22	25
<b>444 082</b>	16	21	24
<b>349 363</b>	18	24	27
<b>349 356</b>	22	25	28
<b>349 349</b>	28	26	29
<b>349 332</b>	35	29	32
<b>349 325</b>	42	38	42
<b>349 318</b>	54	42	46

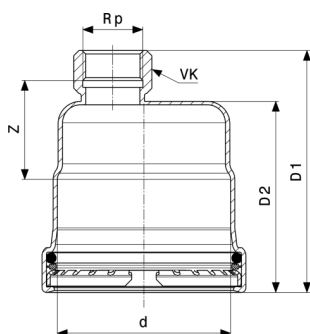

**Profipress XL-Kapa**  
- baker  
**Model 2456XL**

Izdelek	d	Rp	Z	D1	D2	VK
<b>577 780</b>	64,0	¾	45	100	78	30
<b>534 165</b>	76,1	¾	45	107	85	30
<b>534 172</b>	88,9	¾	45	107	85	30
<b>534 189</b>	108,0	¾	46	118	96	30

VK = velikost ključa

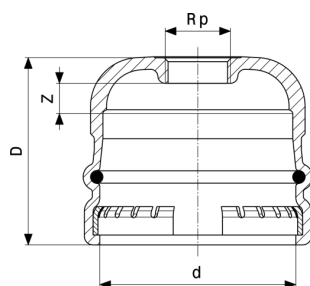

**Sanpress XL-Kapa**  
- rdeča litina  
**Model 2256XL**

Izdelek	d	Rp	Z	D
<b>353 377</b>	76,1	¾	12	76
<b>353 384</b>	88,9	¾	11	77
<b>353 391</b>	108,0	¾	15	89

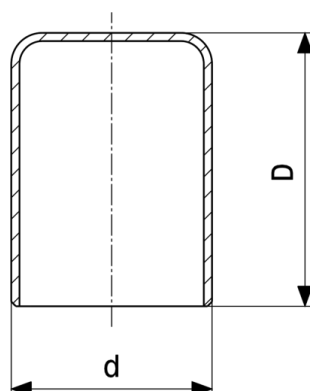

**Profipress-Zamašek**  
- baker  
**Model 2457**

Izdelek	d	D
<b>330 903</b>	15	29
<b>330 897</b>	18	29
<b>314 576</b>	22	30
<b>314 569</b>	28	31
<b>314 545*</b>	42	46
<b>314 538*</b>	54	55

\* = ukinjeno, dobavljivo le do razprodaje zalog

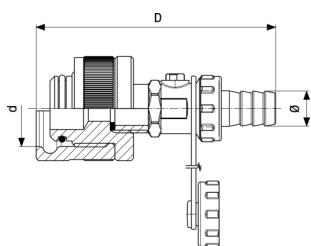

**Čep za tlačni preizkus**  
- medenina  
**Model 2269**

Izdelek	d	D	Ø
<b>290 801</b>	12	117	15
<b>141 523</b>	15	120	15
<b>289 423</b>	18	120	15
<b>140 557</b>	22	119	15
<b>142 568</b>	28	131	15
<b>144 111</b>	35	102	15
<b>144 999</b>	42	107	15
<b>187 798</b>	54	127	15

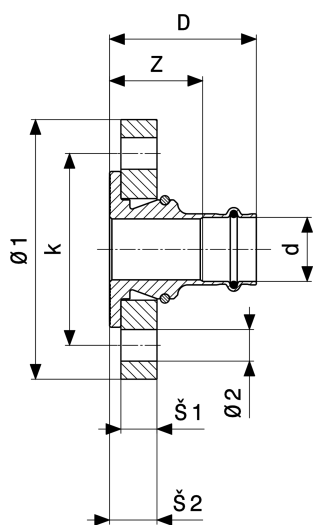

**Sanpress-Prirobnični prehod**  
- rdeča ali silicijeva litina  
**Model 2259.5**

Izdelek	DN	d	Z	D	Š1	Š2	Ø1	Ø2	k	n
<b>479 855</b>	25	28	42	65	16	21	115	14	85	4
<b>479 879</b>	32	35	45	70	16	21	140	18	100	4
<b>479 886</b>	40	42	47	83	16	21	150	18	110	4
<b>479 893</b>	50	54	50	90	16	21	165	18	125	4

k = Ø kroga luknje  
n = število izvrtin



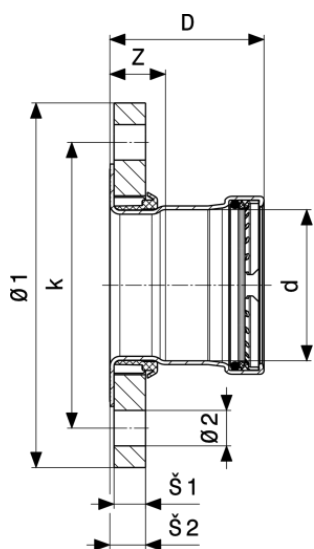

**Profipress XL-Prirobnični prehod**  
 - baker  
**Model 2459.5XL**

Izdelek	DN	d	Z	D	Š1	Š2	Ø1	k	Ø2	n
<b>577 797</b>	65	64,0	28	71	16	18	185	145	18	8
<b>534 042</b>	65	76,1	28	78	16	18	185	145	18	8
<b>817 985</b>	80	76,1						160		8
<b>534 059</b>	80	88,9	30	80	18	20	200	160	18	8
<b>534 066</b>	100	108,0	32	92	18	21	220	180	18	8

k = Ø kroga luknje  
 n = število izvrtin

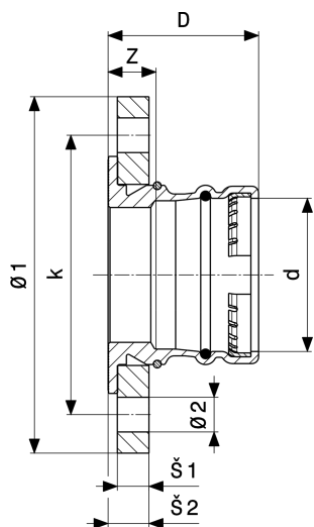

**Sanpress XL-Prirobnični prehod**  
 - rdeča litina  
**Model 2259.5XL**

Izdelek	DN	d	Z	D	Š1	Š2	Ø1	Ø2	k	n
<b>479 954</b>	65	76,1	25	78	16	21	185	18	145	8
<b>479 978</b>	80	88,9	27	80	18	23	200	18	160	8
<b>480 011</b>	100	108,0	17	80	18	23	220	18	180	8

k = Ø kroga luknje  
 n = število izvrtin

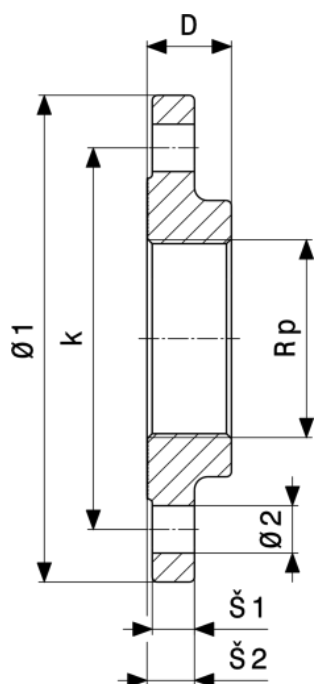

**Sanpress XL-Prirobnica**  
- rdeča ali silicijeva litina  
**Model 2259.2XL**

Izdelek	DN	Rp	Ø1	D	Š1	Š2	Ø2	k	n
641 597	65	2½	185	32	16	18	18	145	8

k = Ø kroga luknje  
n = število izvrtin

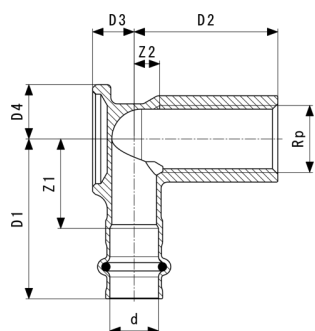

**Sanpress-Stenska pritrdilna plošča**  
- rdeča ali silicijeva litina  
**Model 2225**

Izdelek	d	Rp	L	Z1	Z2	D1	D2	D3	D4
116 552	15	½	45	28	8	50	45	13	21

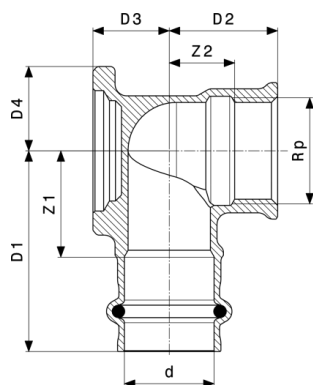

**Sanpress-Stenska pritrdilna plošča**  
 - rdeča ali silicijeva litina  
**Model 2225.5**

Izdelek	d	Rp	Z1	Z2	D1	D2	D3	D4	Z1*	Z2*
<b>291 013</b>	12	½	23	10	40	20	11	18		
<b>444 044</b>	14	½	25	12	44	22	13	21		
<b>107 345</b>	15	½	22	12	44	22	13	17	24	12
<b>444 556</b>	16	½	23	12	42	22	15	18		
<b>281 502</b>	18	½	22	12	44	22	15	18	24	12
<b>335 236</b>	18	¾	28	13	50	24	16	21		
<b>335 229</b>	22	½	27	14	50	24	18	18		
<b>116 057</b>	22	¾	27	16	50	27	19	21		

Izdelek	d	Rp	D1*	D2*	D3*	D4*
<b>291 013</b>	12	½				
<b>444 044</b>	14	½				
<b>107 345</b>	15	½	46	21	13	22
<b>444 556</b>	16	½				
<b>281 502</b>	18	½	46	21	15	22
<b>335 236</b>	18	¾				
<b>335 229</b>	22	½				
<b>116 057</b>	22	¾				

Z\* = mera Z predhodne različice

D\* = dolžina predhodne različice

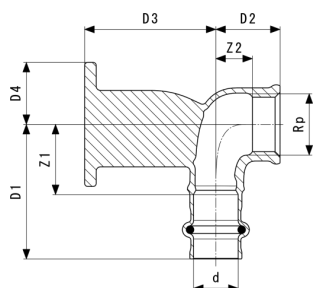

**Sanpress-Stenska pritrdilna plošča**  
- rdeča ali silicijeva litina  
**Model 2225.6**

Izdelek	d	Rp	Z1	Z2	D1	D2	D3	D4
<b>347 307</b>	15	½	24	13	46	22	45	21

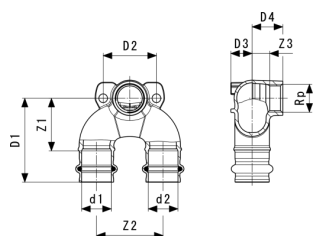

**Sanpress-Dvojna stenska pritrdilna plošča**  
- rdeča ali silicijeva litina  
**Model 2228.7**

Izdelek	d1	Rp	d2	Z1	Z2	Z3	D1	D2	D3	D4
<b>687 892</b>	15	½	15	34	50	10	56	40	13	23
<b>692 797</b>	18	½	18	34	50	10	56	40	14	23
<b>687 908</b>	22	½	22	40	50	12	63	40	16	23

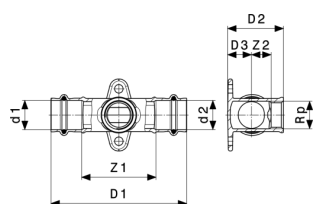

**Sanpress-T-kos stenske pritrdilne plošče**  
- rdeča ali silicijeva litina  
**Model 2217.3**

Izdelek	d1	Rp	d2	Z1	Z2	D1	D2	D3
<b>644 864</b>	15	½	15	48	14	92	36	13
<b>625 726</b>	22	½	22	57	15	104	43	19

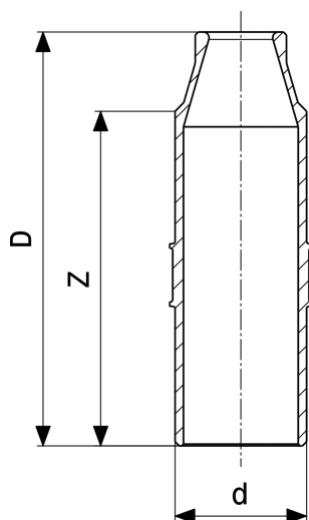

**Šoba za hladno stiskanje**  
- rdeča ali silicijeva litina  
**Model 2211.5**

Izdelek	d	Z	D
695 835	22	54	69
695 842	28	57	74
696 252	35	61	77
696 269	42	81	100
696 276	54	89	113
696 283*	64	103	122

\* = ukinjeno, dobavljivo le do razprodaje zalog

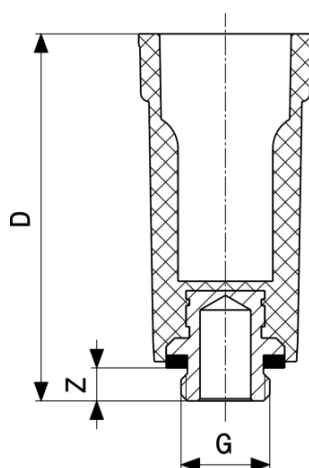

**Čep za tlačni preizkus**  
- umetna masa  
**Model 1516.113**

Izdelek	G	Z	D
116 644	3/8	7	85
100 766	1/2	11	92
107 666	3/4	9	87

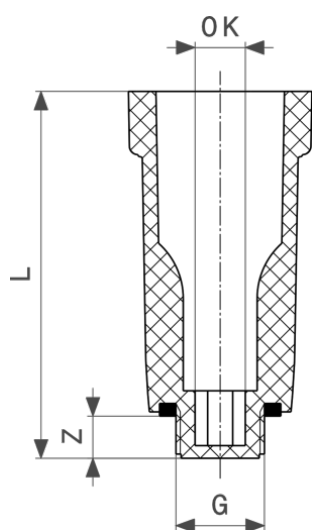

**Čep za tlačni preizkus**  
- umetna masa  
**Model 1516**

Izdelek	G	Z	D	VK
107 796	3/8	10	87	8
100 124	1/2	10	87	10
102 746	3/4	13	90	14

VK = velikost ključa

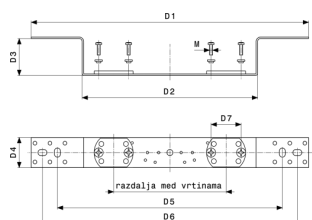

**Držalo**  
- pocinkano jeklo  
**Model 2021.7**

Izdelek	razmak	D1	D2	D3	D4	D5	D6	D7	M
651 350	70/100/150	370	234	48	40	300	340	40	4

M = vrsta navoja

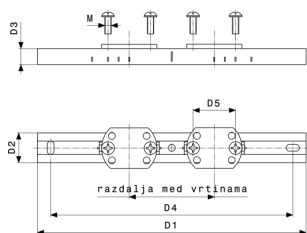

**Držalo**  
- pocinkano jeklo  
**Model 2141.3**

Izdelek	Razmak	D1	D2	D3	D4	D5	M
<b>581 701</b>	80-150	253	28	15	228	40	6

M = vrsta navoja

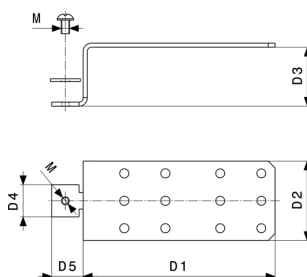

**Držalo**  
- pocinkano jeklo  
**Model 2141.4**

Izdelek	D1	D2	D3	D4	D5	M
<b>586 706</b>	140	58	43	24	23	6

M = vrsta navoja

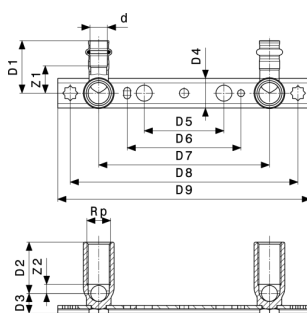

**Sanpress-Montažna plošča**  
**Model 2221**

Izdelek	d	Rp	L	razmak	Z1	Z2	D1	D2	D3	D4
<b>124 502</b>	15	½	45	150/200	24	8	46	45	18	26

Izdelek	d	Rp	L	razmak	D5	D6	D7	D8	D9
<b>124 502</b>	15	½	45	150/200	70	100	150	200	222



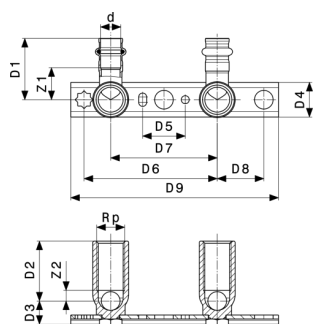

**Sanpress-Montažna plošča  
Model 2221.1**

Izdelek	d	Rp	L	razmak	Z1	Z2	D1	D2	D3	D4
135 119	15	½	45	80/100	24	8	46	45	18	26

Izdelek	d	Rp	L	razmak	D5	D6	D7	D8	D9
135 119	15	½	45	80/100	32	100	80	35	156

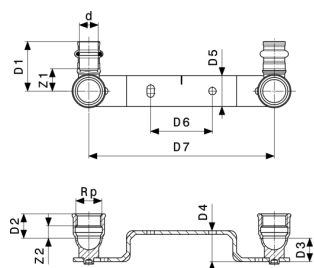

**Sanpress-Montažna plošča  
Model 2222**

Izdelek	d	Rp	razmak	Z1	Z2	D1	D2	D3	D4	D5
295 462	15	½	150	24	12	40	22	17	25	25

Izdelek	d	Rp	razmak	D6	D7
295 462	15	½	150	50	150

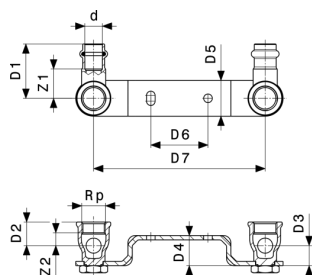

**Sanpress-Montažna plošča  
Model 2222.6EX**

Izdelek	d	Rp	razmak	Z1	Z2	D1	D2	D3	D4	D5
357 351	12	3/8	120	21	9	38	17	14	21	25

Izdelek	d	Rp	razmak	D6	D7
357 351	12	3/8	120	40	120

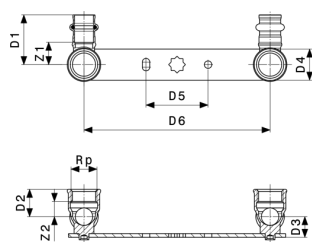

**Sanpress-Montažna plošča  
Model 2222.05**

Izdelek	d	Rp	razmak	Z1	Z2	D1	D2	D3	D4	D5
308 681	15	1/2	150	18	12	40	22	17	25	50

Izdelek	d	Rp	razmak	D6
308 681	15	1/2	150	150

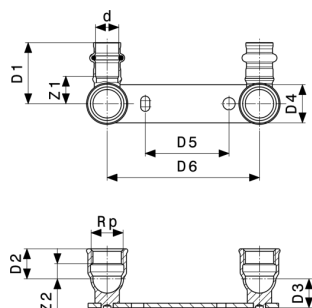

**Sanpress-Montažna plošča  
Model 2222.2**

Izdelek	d	Rp	razmak	Z1	Z2	D1	D2	D3	D4	D5
308 674	15	1/2	100	18	12	40	22	17	25	55

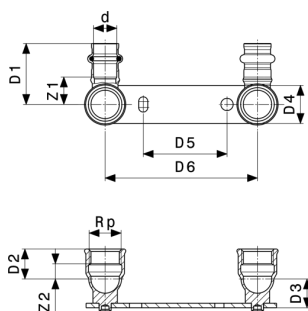

**Sanpress-Montažna plošča  
Model 2222.2**

Izdelek	d	Rp	razmak	D6
<b>308 674</b>	15	½	100	100

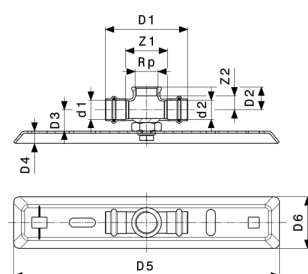

**Sanpress-Montažna plošča  
Model 2218.4**

Izdelek	d1	Rp	d2	Z1	Z2	D1	D2	D3	D4	D5
<b>625 078*</b>	22	¾	22	49	16	96	27	25	14	310

Izdelek	d1	Rp	d2	D6
<b>625 078*</b>	22	¾	22	60

\* = ukinjeno, dobavljivo le do razprodaje zalog

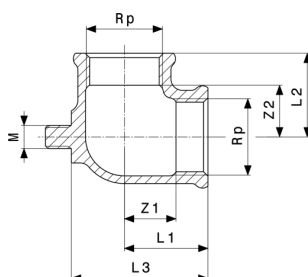

**Priključni kotni fitting 90°  
- rdeča ali silicijeva litina  
Model 94477.0-713**

Izdelek	Rp	Z1	Z2	D1	D2	D3	M
<b>374 570<sup>1</sup></b>	½	15	15	25	25	41	8
<b>489 298<sup>1</sup></b>	¾	18	18	29	29	47	8

M = vrsta navoja

1) rdeča litina

2) medenina

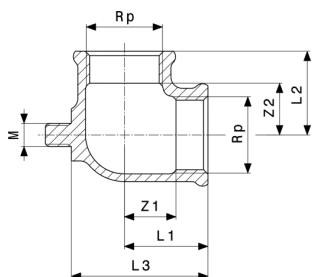

**Priključni kotni fitting 90°**  
 - rdeča ali silicijeva litina  
**Model 94477.0-713**

Izdelek	Rp	Z1	Z2	D1	D2	D3	M
<b>138 066<sup>2</sup></b>	1	15	15	35	35	57	8

M = vrsta navoja

1) rdeča litina

2) medenina

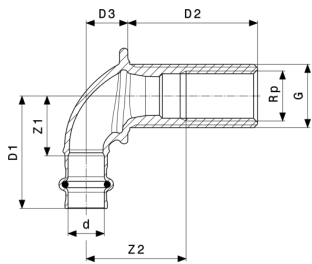

**Sanpress-Stenski preboj**  
 - rdeča ali silicijeva litina  
**Model 2232.1**

Izdelek	d	Rp	G	L	Z1	Z2	D1	D2	D3
<b>279 301</b>	15	½	¾	25	25	27	47	25	18
<b>279 318</b>	15	½	¾	35	25	22	47	35	18
<b>279 288</b>	15	½	¾	55	25	42	47	55	18
<b>279 295</b>	15	½	¾	65	25	52	47	65	18

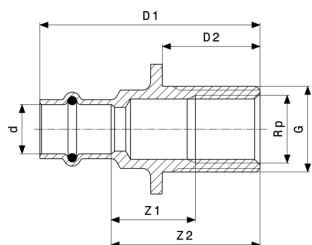

**Sanpress-Stenski preboj**  
 - rdeča ali silicijeva litina  
**Model 2232.3**

Izdelek	d	Rp	G	L	Z1	Z2	D1	D2
<b>325 060</b>	15	½	¾	30	26	46	68	31

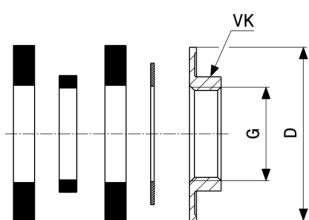

**Namestitveni komplet**  
**Model 1526.414-897**

Izdelek	G	VK	D
<b>104 887</b>	¾	29	49

VK = velikost ključa  
D = zunanji premer

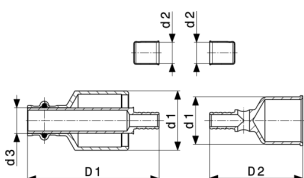

**Smartloop-Priključni komplet**  
- rdeča ali silicijeva litina  
**Model 2276.1**

Izdelek	d1	d2	d3	D1	D2
<b>632 229</b>	28/35	12	15	78	55
<b>470 289</b>	28	12	15	78	55
<b>470 272</b>	35	12	15	78	59

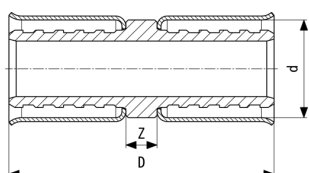

**Smartloop-Spojka**  
**Model 2276.8**

Izdelek	za d	Z	D
<b>643 188</b>	12	4	34

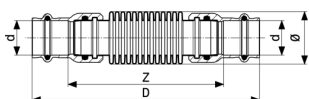

**Kompenzator**  
**Model 2251**

Izdelek	d	Z	D	Ø
<b>690 250</b>	15	100	144	25
<b>690 267</b>	18	104	148	27
<b>690 274</b>	22	102	149	34

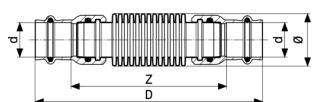
**Kompenzator  
Model 2251**

Izdelek	d	Z	D	Ø
690 281	28	121	168	41
690 298	35	123	174	50
690 304	42	127	199	60
690 311	54	137	217	72

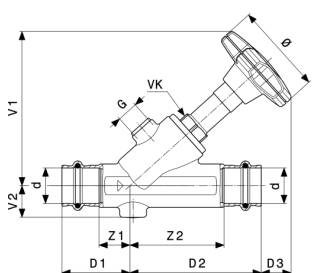
**Easytop-Poševnosedežni ventil  
Model 2237.5**

Izdelek	DN	d	Z1	Z2	D1	D2	D3	V1	V2	Ø
756 864	15	15	15	46	37	68	19	84	16	60
756 871	15	18	15	46	37	68	19	84	18	60
756 888	20	22	20	60	43	83	17	96	20	60
756 895	25	28	23	66	46	89	31	115	23	73
756 901	32	35	25	80	50	105	32	131	27	73
756 918	40	42	29	84	65	120	41	154	31	98
756 925	50	54	30	105	70	145	43	178	37	98

Izdelek	DN	d	G	VK
756 864	15	15	¼	19
756 871	15	18	¼	19
756 888	20	22	¼	19
756 895	25	28	¼	27
756 901	32	35	¼	27
756 918	40	42	¼	39
756 925	50	54	¼	32

VK = velikost ključa

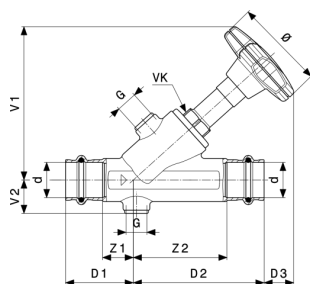

**Easytop-Poševnosedežni ventil KRV  
Model 2238.5**

Izdelek	DN	Z1	Z2	D1	D2	D3	V1	V2	Ø	G
<b>757 199</b>	15	15	46	37	68	20	85	17	60	¼
<b>757 205</b>	15	15	46	37	68	20	85	19	60	¼
<b>757 212</b>	20	20	60	43	83	17	96	21	60	¼
<b>757 229</b>	25	23	66	46	89	32	116	24	73	¼
<b>757 236</b>	32	25	80	50	105	33	131	28	73	¼
<b>757 243</b>	40	29	84	65	120	36	149	32	98	¼
<b>757 250</b>	50	30	105	70	145	35	171	38	98	¼

Izdelek	DN	VK
<b>757 199</b>	15	19
<b>757 205</b>	15	19
<b>757 212</b>	20	19
<b>757 229</b>	25	27
<b>757 236</b>	32	27
<b>757 243</b>	40	32
<b>757 250</b>	50	32

VK = velikost ključa

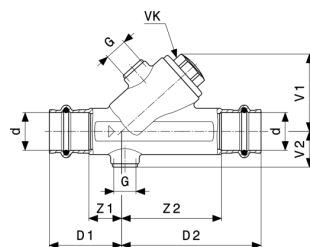

**Easytop-Protipovratna zapora  
Model 2239.4**

Izdelek	DN	d	Z1	Z2	D1	D2	V1	V2	G	VK
<b>757 526</b>	15	15	15	46	37	68	41	17	¼	19
<b>757 533</b>	15	18	15	46	37	68	41	19	¼	19
<b>757 540</b>	20	22	20	60	43	83	46	21	¼	19

VK = velikost ključa

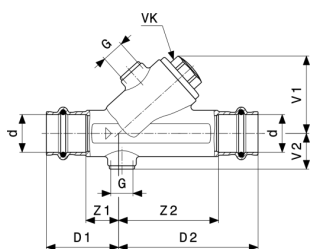

**Easytop-Protipovratna zapora  
Model 2239.4**

Izdelek	DN	d	Z1	Z2	D1	D2	V1	V2	G	VK
<b>757 557</b>	25	28	23	66	46	89	59	24	¼	27
<b>757 564</b>	32	35	25	80	50	105	67	28	¼	27
<b>757 571</b>	40	42	29	84	65	120	78	32	¼	32
<b>757 588</b>	50	54	30	105	70	145	90	38	¼	32

VK = velikost ključa

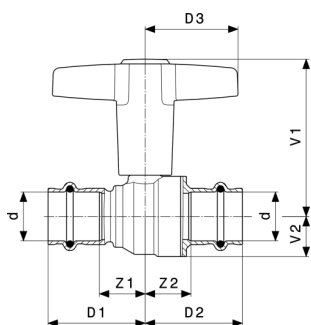

**Easytop-Kroglični ventil  
Model 2275**

Izdelek	DN	d	Z1	Z2	D1	D2	D3	V1	V2
<b>746 377</b>	15	15	20	20	42	42	43	69	15
<b>746 384</b>	15	18	20	20	42	42	43	69	15
<b>746 391</b>	20	22	21	20	45	43	43	72	18
<b>746 407</b>	25	28	26	26	49	50	51	91	22
<b>746 414</b>	32	35	34	27	59	52	51	97	28
<b>746 421</b>	40	42	37	32	73	68	60	119	34
<b>746 438</b>	50	54	44	38	84	78	60	127	41



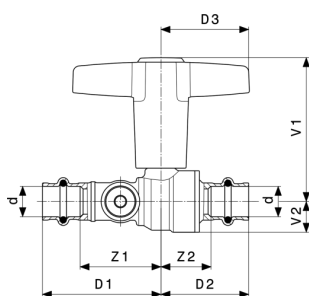

**Easytop-Kroglični ventil  
Model 2275.3**

Izdelek	DN	d	Z1	Z2	D1	D2	D3	V1	V2
<b>746 681</b>	15	15	35	20	57	42	43	69	15
<b>746 698</b>	15	18	34	20	56	42	43	69	15
<b>746 704</b>	20	22	38	20	62	43	43	72	18
<b>746 711</b>	25	28	43	26	66	50	51	91	22
<b>746 728</b>	32	35	57	27	82	52	51	97	28
<b>746 735</b>	40	42	62	32	98	68	60	119	34
<b>746 742</b>	50	54	70	38	110	78	60	127	42

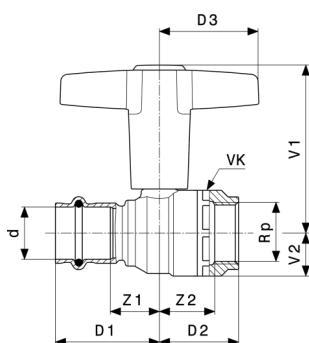

**Easytop-Kroglični ventil  
Model 2275.4**

Izdelek	DN	d	Rp	Z1	Z2	D1	D2	D3	V1	V2
<b>746 759</b>	15	15	½	20	24	42	33	43	69	15
<b>746 766</b>	15	18	½	20	24	42	33	43	15	15
<b>746 773</b>	20	22	¾	21	22	45	34	43	72	18
<b>746 780</b>	25	28	1	26	29	49	41	51	91	22
<b>746 797</b>	32	35	1¼	30	34	55	48	51	97	28
<b>746 803</b>	40	42	1½	37	39	73	52	60	119	34
<b>746 810</b>	50	54	2	44	45	84	62	60	127	42

Izdelek	DN	d	Rp	VK
<b>746 759</b>	15	15	½	28

VK = velikost ključa

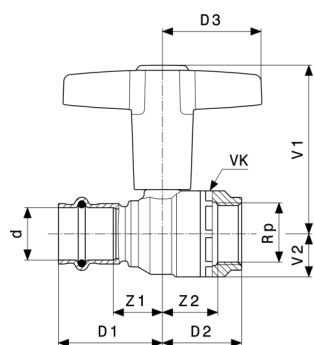

**Easytop-Kroglični ventil**  
**Model 2275.4**

Izdelek	DN	d	Rp	VK
<b>746 766</b>	15	18	½	28
<b>746 773</b>	20	22	¾	35
<b>746 780</b>	25	28	1	43
<b>746 797</b>	32	35	1¼	49
<b>746 803</b>	40	42	1½	57
<b>746 810</b>	50	54	2	70

VK = velikost ključa

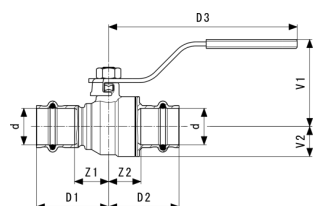

**Easytop-Kroglični ventil**  
**- silicijeva litina**  
**Model 2275.10**

Izdelek	Z1	Z2	D1	D2	D3	V1	V2
<b>774 851</b>	20	20	42	42	116	51	15
<b>774 868</b>	20	20	42	42	116	51	15
<b>774 875</b>	21	20	45	43	116	53	18
<b>774 882</b>	26	26	49	50	147	63	22
<b>774 899</b>	30	27	55	52	147	68	28
<b>774 905</b>	37	32	73	68	156	77	34
<b>774 912</b>	44	38	84	78	156	84	42

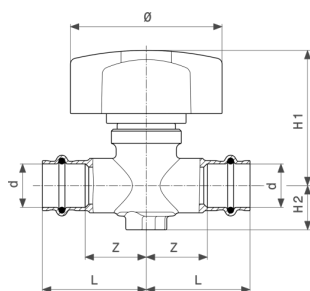

**Easytop-Prosto pretočni ventil  
Model 2278**

Izdelek	d	Z	D	V1	V2	Ø
<b>747 312</b>	15	32	54	70	23	79
<b>747 329</b>	18	31	53	70	23	79
<b>747 336</b>	22	31	55	70	23	79

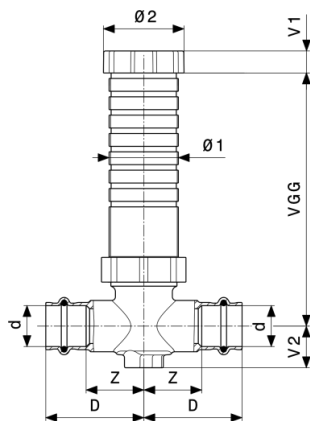

**Easytop-Podometni prosto pretočni ventil  
Model 2278.5**

Izdelek	d	VGG	Z	D	V1	V2	Ø1	Ø2
<b>747 343</b>	15	45-130	32	54	12	23	38	44
<b>747 350</b>	18	45-130	31	53	12	23	38	44
<b>747 367</b>	22	45-130	31	55	12	23	38	44

VGG = Vgradna globina

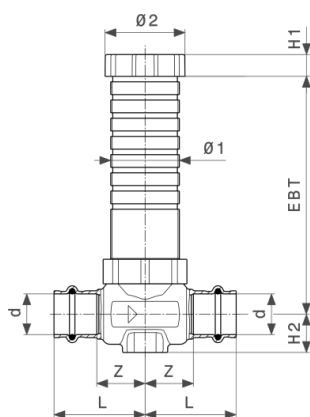

**Easytop-Podometni ravni ventil**  
**Model 2235.2**

Izdelek	DN	d	VGG	Z	D	V1	V2	Ø1	Ø2
<b>755 591</b>	15	15	45-130	28	50	12	21	38	44
<b>755 607</b>	15	18	45-130	28	50	12	21	38	44
<b>755 614</b>	20	22	45-130	27	50	12	21	38	44
<b>755 621</b>	25	28	45-130	27	50	12	21	38	44

VGG = Vgradna globina

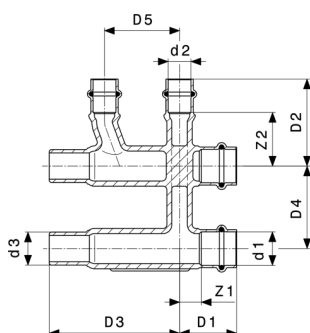

**Sanpress-Razdelilnik za estrih**  
- rdeča litina  
**Model 2252**

Izdelek	d1	d2	d3	Z1	Z2	D1	D2	D3	D4	D5
<b>364 298<sup>1</sup></b>	22	10	22	15	33	38	50	87	55	50
<b>397 166</b>	22	15	22	15	36	38	58	87	55	50

<sup>1</sup>) Spoj s hladnim stiskanjem d10 je treba izvesti s čeljustmi za hladno stiskanje 12.

\* = ukinjeno, dobavljivo le do razprodaje zalog

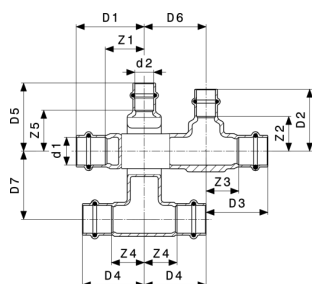

**Sanpress-Križni T-kos**  
- rdeča litina  
**Model 2249.3**

Izdelek	d1	d2	Z1	Z2	Z3	Z4	Z5	D1	D2	D3
<b>493 325</b>	15	15	33	28	28	28	33	55	50	50
<b>493 332</b>	18	15	33	28	28	28	33	55	50	50
<b>493 356</b>	22	15	32	28	27	27	33	55	50	50
<b>493 349</b>	22	18	32	28	27	27	33	55	50	50

Izdelek	d1	d2	D4	D5	D6	D7
<b>493 325</b>	15	15	50	55	50	55
<b>493 332</b>	18	15	50	55	50	55
<b>493 356</b>	22	15	50	55	50	55
<b>493 349</b>	22	18	50	55	50	55

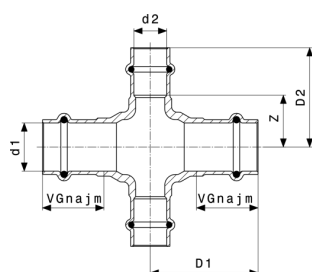

**Sanpress-Križni priključek**  
- rdeča ali silicijeva litina  
**Model 2244**

Izdelek	d1	d2	VGnajm	Z	D1	D2
<b>424 435*</b>	15	15	22	20	50	42
<b>424 473*</b>	18	15	22	21	50	43
<b>424 497</b>	22	15	24	24	50	46

VGnajm = najmanjša vtična globina  
\* = ukinjeno, dobavljivo le do razprodaje zalog

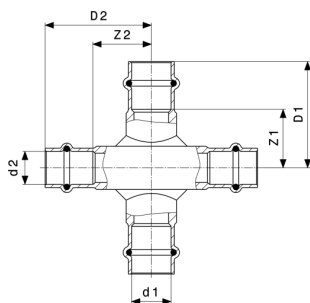

**Sanpress-Križni kos**  
- rdeča litina  
**Model 2248**

Izdelek	d1	d2	Z1	Z2	D1	D2
<b>322 410</b>	15	15	26	26	48	48
<b>322 427</b>	18	15	27	27	49	49
<b>323 370</b>	22	15	27	30	50	52
<b>323 363</b>	28	15	31	33	54	55

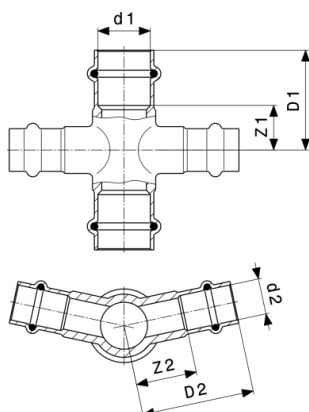

**Sanpress-Križni kos 24°**  
- rdeča litina  
**Model 2247**

Izdelek	d1	d2	Z1	Z2	D1	D2
<b>325 985</b>	18	15	21	24	42	46
<b>325 978</b>	22	15	19	21	43	48

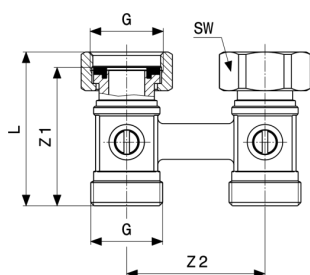

**Priključni element radiatorja**  
- medenina mat ponikljana  
**Model 1096.5**

Izdelek	G	razmak	Z1	D	VK
<b>359 102</b>	¾	50	48	54	30

VK = velikost ključa

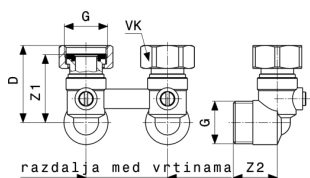

**Priključni element radiatorja**  
- medenina mat ponikljana  
**Model 1097.5**

Izdelek	G	razmak	Z1	Z2	D	VK
<b>359 133</b>	¾	50	42	27	47	30

VK = velikost ključa

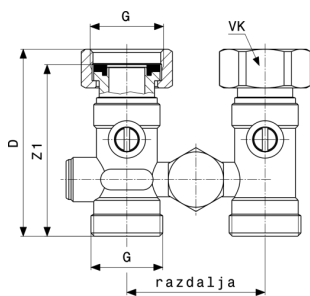

**Priključni element radiatorja**  
- medenina mat ponikljana  
**Model 1096.0**

Izdelek	G	razmak	Z1	D	VK
<b>359 096</b>	¾	50	62	68	30

VK = velikost ključa

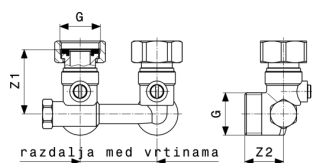

**Priključni element radiatorja**  
 - medenina mat ponikljana  
**Model 1097.0**

Izdelek	G	razmak	Z1	Z2	D	VK
<b>359 126</b>	¾	50	43	25	47	30

VK = velikost ključa

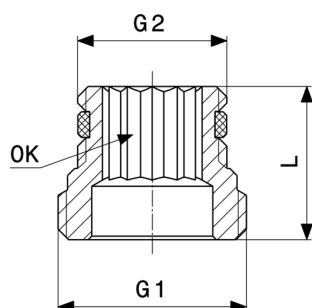

**Adapterski komplet**  
 - medenina  
**Model 1096.8**

Izdelek	G1	G2	D	VK
<b>357 122</b>	½	¾	22	12

VK = velikost ključa

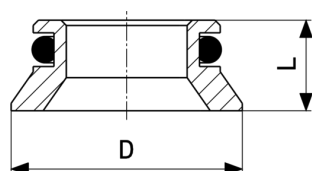

**Adapterski komplet**  
**Model 1096.9**

Izdelek	D	D
<b>308 872</b>	22	9

D = zunanji premer



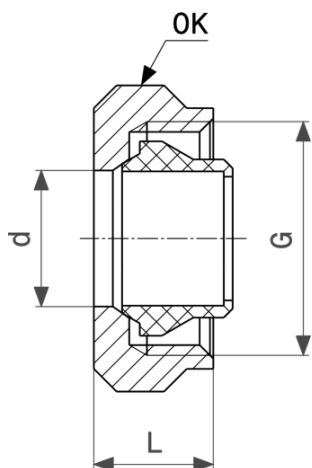

**Privijalo**  
- medenina ponikljana  
**Model 94385.1**

Izdelek	d	G	D	VK
<b>112 608</b>	12	¾	14	30
<b>105 358</b>	15	¾	14	30

VK = velikost ključa

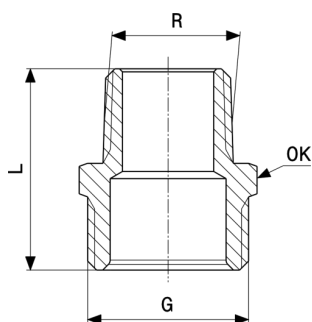

**Adapterski komplet**  
- medenina mat ponikljana  
**Model 1022.6**

Izdelek	R	G	D	VK
<b>153 687</b>	½	¾	33	27

VK = velikost ključa

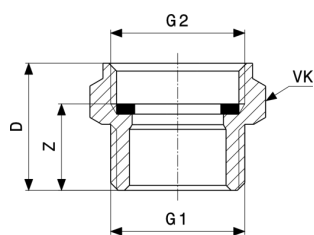

**Adapterski komplet**  
- medenina mat ponikljana  
**Model 1022.5**

Izdelek	G1	G2	Z	D	VK
<b>137 342</b>	3/4	3/4	17	25	30

VK = velikost ključa

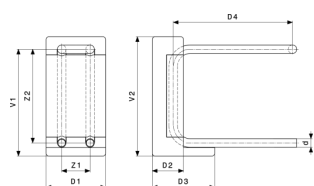

**Priključni blok radiatorja**  
**Model 1097.6**

Izdelek	d	Z1	Z2	D1	D2	D3	D4	V1	V2
<b>364 045</b>	15	50	165	105	55	110	210	188	210
<b>379 698</b>	15	50	235	105	55	110	210	258	280

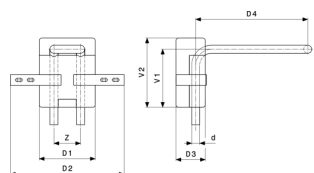

**Priključni blok radiatorja**  
**Model 1097.9**

Izdelek	d	V	Z	D1	D2	D3	D4	V1	V2
<b>586 379</b>	15	150	50	105	214	55	210	109	130

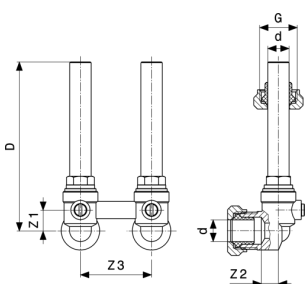

**Priključni komplet radiatorja**  
 - medenina mat ponikljana  
**Model 1097.7**

Izdelek	d	G	Z1	Z2	Z3	D
<b>364 052</b>	15	¾	15	11	50	118

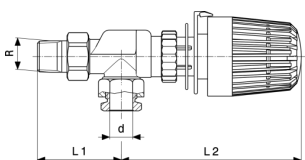

**Aksialni ventil radiatorja**  
 - medenina ponikljana  
**Model 1075.96**

Izdelek	d	R	D1	D2
<b>360 405</b>	15	½	56	120

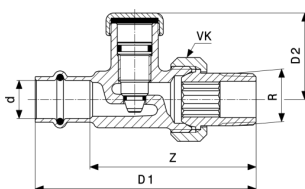

**Sanpress-Vijačni spoj za povratni tok**  
 - rdeča litina  
**Model 2272.2**

Izdelek	d	R	Z	D1	D2	VK
<b>326 364</b>	15	½	67	89	35	29

VK = velikost ključa

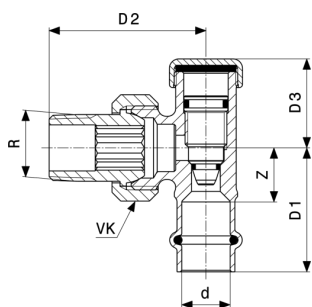

**Sanpress-Vijačni spoj za povratni tok**  
- rdeča litina  
**Model 2272.1**

Izdelek	d	R	Z	D1	D2	D3	VK
<b>326 357</b>	15	½	17	39	50	28	29

VK = velikost ključa

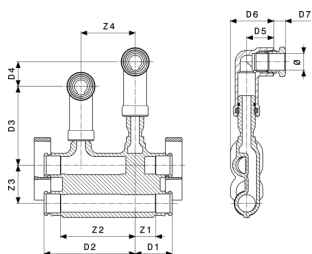

**Priključni element za podnožne letve in radiatorje**  
- rdeča litina  
**Model 2277.2**

Izdelek	Ø	Z1	Z2	Z3	Z4	D1	D2	D3	D4	D5
<b>662 509</b>	15	19	69	35	50	34	84	73	23	25

Izdelek	Ø	D6	D7
<b>662 509</b>	15	40	11

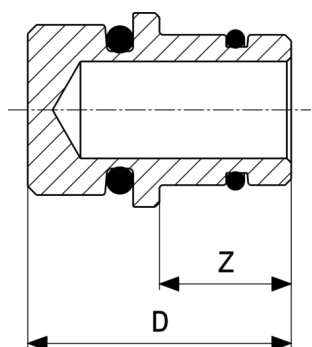

**Vtični adapter**  
- rdeča ali silicijeva litina  
**Model 2233.6**

Izdelek	Z	D
<b>663 346</b>	15	30

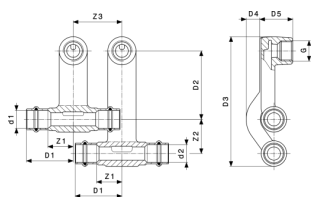

**Sanpress-Priključni element radiatorja**  
 - rdeča litina  
**Model 2273.1**

Izdelek	d1	G	d2	Z1	Z2	Z3	D1	D2	D3	D4
<b>446 628</b>	15	½	15	26	35	50	48	70	131	14
<b>446 635</b>	18	½	18	26	35	50	48	70	131	14

Izdelek	d1	G	d2	D5
<b>446 628</b>	15	½	15	34
<b>446 635</b>	18	½	18	31

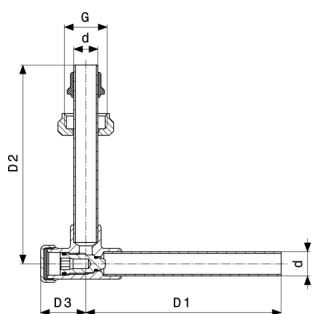

**Priključni komplet radiatorja**  
 - medenina ponikljana  
**Model 2272.5**

Izdelek	d	G	L1	D2	D3
<b>360 399</b>	15	¾	121	123	28

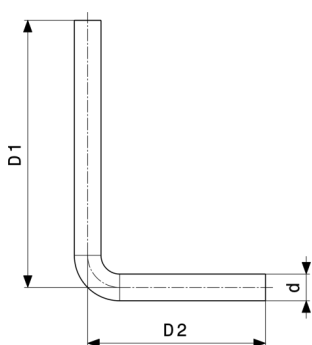

**Priključni cevni lok 90°**  
 - nerjavno jeklo  
**Model 2271.1**

Izdelek	d	D1	D2
<b>449 292</b>	15	150	100
<b>366 056</b>	15	350	100

# Kolofon

## **Viega GmbH & Co. KG**

Viega Platz 1

57439 Attendorn

Germany

Phone: +49/2722/61-0

Fax: +49/2722/61-1566

The Viega GmbH & Co. KG is represented by the general partners: Viega Management B.V. (Managing directors: Michael Klenz, Sebastian Lelgemann) and Viega Management GmbH (Managing directors: Michael Klenz, Sebastian Lelgemann)

Pri paketu Submittal Package gre za nezavezujoče informacije, ki so vam dane na razpolago. Vse vsebine tega paketa Submittal Package so sestavljene z veliko skrbnostjo. Vseeno ne moremo zagotoviti posodobljenosti, pravilnosti in celovitosti informacij. Paket Submittal Package ob naročilu ni del pogodbe.