

Viega Smartpress

Inlämningspaket

SE



viega

innehållsförteckning

1	Produktgruppsbeskrivning	3
2	Tillåtna rör	5
3	Certifiering	7
4	Z-dimensioner	10
5	Avtryck	38

Produktgruppsbeskrivning

Flödesoptimerat presskopplingsystem med presskopplingar av rödgods och rostfritt stål och flerskiktsrör. Flerskiktsrör, dimensionellt stabilt, syretätning, färg: vit. Presskoppling med PPSU-stödkropp för att säkerställa anslutningens täthet och mekaniska styrka. Säker och snabb anslutning utan att bredda och kalibrera rörändarna på grund av pressteknologi utan O-ring i alla rördimensioner. För skydd är rören utrustade med rörproppar. Lämplig för utvändiga installationer av fördelar- och stigarledning.

Flerskiktsrör

yttrefärg vit
lämpad för dricksvatten- och värmeinstallationer

Märkning

Tillverkare, rördimension, batch nummer, grön punkt på pressvulsten, system godkännande

Presskoppling med SC-Contur

Kopplingar som ej blivit pressade vid monteringen läcker när anläggningen fylls. Intervall för trycktestning:
Intervall för trycktestning
min. vattentryck: 0,1 MPa/1 bar/14,5 PSI
max. vattentryck: 0,65 MPa/6,5 bar/94,3 PSI
min. lufttryck: 22 hPa/22 mbar/0,3 PSI
max. lufttryck: 0,3 MPa/3 bar/43,5 PSI

Dimensioner

d16–63

Verktyg

Funktionssäkerheten för Viega-presskopplingsystem beror i första hand på att de använda pressmaskinerna och pressverktygen är i felfritt skick. För att utföra pressningarna rekommenderar vi att Viega-pressverktyg används. Viega-pressverktyg måste underhållas regelbundet av auktoriserade servicepartners.

Tillämpningsområden

Dricksvatten
Värmeanläggningar
Regnvatten
Tryckluftssystem

Observera

Pressanslutningssystemet Viega Smartpress är lämpligt för skapande av dricksvatteninstallationer enligt DIN 1988-200 och EN 806-2 med hänsyn till materialval enligt DIN EN 12502-1 och DIN 50930-6. Kontakta Viega vid användning för andra användningsområden och om du är osäker på rätt materialval. För detaljerad information om tillämpningar, begränsningar och nationella standarder och riktlinjer, se produktinformation, antingen i tryckt format eller på Viegas hemsida.

Driftvillkor dricksvatteninstallationer

driftstemperatur max. 70 °C / 158 °F
driftstryck max. 1,0 MPa / 10 bar / 145 PSI

Driftvillkor värmeinstallationer

driftstemperatur max. 80° C / 176 °F
driftstryck max. 1,0 MPa / 10 bar / 145 PSI

Material

Rödgoods: CC499K
rostfritt stål 1.4401

Med förbehåll för ändringar utan föregående meddelande!

De senaste Z- och installationsdimensionerna samt ytterligare teknisk information finns på Viegas hemsida och måste kontrolleras innan inköp, planering, byggnadsarbete och användning. Våra produkter optimeras kontinuerligt.





Denna produktbeskrivning innehåller viktig information om val av produkt och system, montering, idrifttagning samt avsedd användning och vid behov om underhållsåtgärder. Denna information om produkter, deras funktioner och tillämpningstekniker baseras på för närvarande giltiga standarder i Europa (t.ex. EN) och / eller i Tyskland (t.ex. DIN / DVGW). Vissa avsnitt i texten kan hänvisa till tekniska föreskrifter i Europa / Tyskland. Dessa bör betraktas som rekommendationer för andra länder där inga motsvarande nationella krav finns. Tillämpliga nationella lagar, standarder, förordningar, direktiv och andra tekniska bestämmelser prioriteras framför de tyska / europeiska direktiven som anges i denna produktbeskrivning: Informationen här är inte bindande för andra länder och regioner och bör förstås som rekommendation.











Tillåtna rör









rörmaterial	Modell	artikel	yttre Ø	vägg tjocklek	utrustningar	
PE-Xc/Al/PE-Xc	4703	607 258	16	2,0		
		607 272	20	2,3		
		607 289	25	2,8		
		586 935	32	3,2		
		586 942	40	3,5		
		588 052	50	4,0		
		588 069	63	4,5		
	4705	607 210	16	2,0		
		607 234	20	2,3		
		607 241	25	2,8		
		699 208	32	3,2		
	PE	4704	607 302	16	2,0	svart skyddsror
			607 326	20	2,3	svart skyddsror
			761 455	25	2,8	svart skyddsror
PE-Xc/Al/PE-Xc	4704.1	691 455	16	2,0	blått skyddsror	
		691 462	16	2,0	rött skyddsror	
		691 479	20	2,3	blått skyddsror	
		691 486	20	2,3	rött skyddsror	
	4705.5	734 060	16	2,0	omgivande isolering 6 mm blå ($\lambda=0,040$ W/(mK))	
		734 077	16	2,0	omgivande isolering 6 mm röd ($\lambda=0,040$ W/(mK))	
		751 401	20	2,3	omgivande isolering 6 mm blå ($\lambda=0,040$ W/(mK))	
		751 418	20	2,3	omgivande isolering 6 mm röd ($\lambda=0,040$ W/(mK))	
	4705.1	679 606	16	2,0		
	PE-RT/Al/PE-RT	4705.01	751 425	16	2,0	
			751 432	16	2,0	
4708		662 585	16	2,0		
		662 592	20	2,3		
4708.1		662 608	16	2,0	PE-skyddsror svart	
4708.5		662 622	16	2,0	omgivande isolering 6 mm blå ($\lambda=0,040$ W/(mK))	

rörmaterial	Modell	artikel	yttre Ø	vägg tjocklek	utrustningar
PE-Xc/Al/PE-Xc	4705.6	607 388	25	2,8	omgivande isolering 9 mm blå ($\lambda=0,040$ W/(mK))
		784 805	25	2,8	omgivande isolering 9 mm röd ($\lambda=0,040$ W/(mK))
		761 202	32	3,2	omgivande isolering 9 mm blå ($\lambda=0,040$ W/(mK))
		784 812	32	3,2	omgivande isolering 9 mm röd ($\lambda=0,040$ W/(mK))
	4705.4	830 755	16	2,0	grå isolering runt 13 mm ($\lambda=0,040$ W/(mK))
		830 762	20	2,3	grå isolering runt 13 mm ($\lambda=0,040$ W/(mK))
		830 779	25	2,8	grå isolering runt 13 mm ($\lambda=0,040$ W/(mK))

Certifiering

Dubai	Dubai Central laboratory Department Attestation of Conformity Viega Smartpress, metal fittings for plastic piping system
	BCCA Certificate Viega Smartpress
BULGARKONTROLA	BULGARKONTROLA Certificate of Conformity Viega Smartpress
VUPS	VUPS Certificate Viega Smartpress
	AENOR Certificate Viega Smartpress
	Eurofins Certificate Viega Smartpress
	CSTB QB Certificate Viega Smartpress
Eurofins	Eurofins Certificate of sanitary conformity (ACS) Viega Smartpress
	WRAS Certificate Viega Smartpress
EMI	EMI certificate Profipress, Sanpress, Easytop, Sanpress Inox, Pexfit Pro Fosta, Smartpress, gunmetal threaded fittings
EMI	EMI Certificate of Constancy of Performance Smartpress/Pexfit Pro

	<p>ICIM Hygiene certificate Profipress, Profipress XL, Sanpress Inox, Sanpress Inox XL, Sanpress, Sanpress XL, Sanfix Fosta, Raxofix, Smartpress, gunmetal threaded fittings, soldered fittings</p>
	<p>IKRAM Product Certificate of Conformity Smartpress, copper alloy/PPSU fittings</p>
	<p>IKRAM Product Certificate of Conformity Smartpress, stainless steel/PPSU fittings</p>
	<p>IKRAM Product Certificate of Conformity Smartpress/Pexfit Pro, PE-Xc/Al/PE-Xc</p>
	<p>Gastec Certificate Smartpress G</p>
	<p>KOMO Product certificate Flexible corrugated protection pipes of PE</p>
	<p>KOMO Product certificate Metal fittings for plastics piping system Pexfit Pro/Smartpress</p>
	<p>KOMO Product certificate Viega Smartpress PE-Xc/Al/PE-Xc piping system</p>
	<p>KOMO Product certificate Viega Smartpress PE-RT/Al/PE-RT piping system</p>
	<p>KIWA Product certificate Metal fittings for plastic piping system Pexfit Pro/Smartpress</p>
	<p>KIWA Product certificate Viega Smartpress PE-Xc/Al/PE-Xc piping system</p>

	KIWA Product certificate Viega Smartpress PE-RT/Al/PE-RT piping system
	KOMO Product certificate PE-RT/Al pipes
	KOMO Product certificate PPSU Fittings
	KOMO Product certificate PE-Xc/Al pipes
	KIWA Product certificate PE-RT/Al pipes
	KIWA Product certificate PPSU Fittings
	KIWA Product certificate PE-Xc/Al pipes
SINTEF	SINTEF Certificate Viega Smartpress
EITS	EITS Technical Approval Viega Smartpress
EITS	EITS Certificate Viega Smartpress
	RISE Typpgodkännande med beslut om tillverkningskontroll viega Smartpress
STL	Singapore Test Lab Test Certificate Smartpress
UKRCERTIFICATION	LLC UKRCertification Certificate of conformity Pexfit Pro, Smartpress

Z-dimensioner

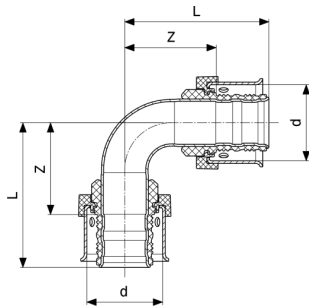

Viega Smartpress böj 90°
- rostfritt stål
Modell 6716

artikel	d	Z	L
729 844	16	26	39
729 851	20	25	39
729 868	25	27	46
729 875	32	35	59
731 922	40	70	94
731 939	50	83	112
731 946	63	93	128

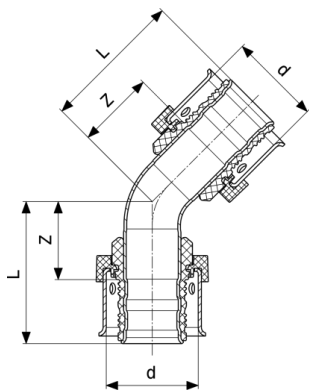

Viega Smartpress böj 45°
- rostfritt stål
Modell 6726

artikel	d	Z	L
730 154	25	18	37
730 161	32	23	48
733 995	40	50	74
734 008	50	58	87
734 015	63	65	100

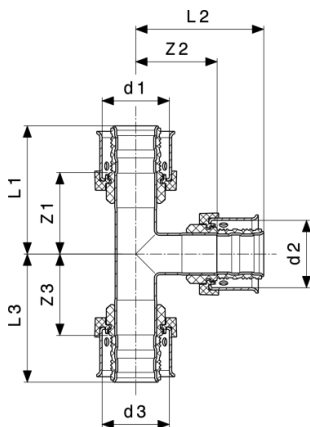

Viega Smartpress T-rör
- rostfritt stål
Modell 6718

artikel	d1	d2	d3	Z1	Z2	Z3	L1	L2	L3
729 929	16	16	16	27	27	27	40	40	40
729 936	16	20	16	28	24	26	42	38	42
729 967	20	16	16	31	31	26	44	44	40
729 950	20	16	20	24	28	24	38	42	38
729 974	20	20	16	24	24	27	38	38	42
729 943	20	20	20	24	24	24	38	38	38
730 048	25	16	16	25	31	30	43	45	44
730 000	25	16	20	25	31	29	43	45	43
729 998	25	16	25	25	31	25	43	45	43
730 017	25	20	20	25	29	29	43	43	43
730 024	25	20	25	25	29	25	43	43	43
730 055	25	25	16	25	25	30	43	43	44
730 031	25	25	20	25	25	29	43	43	43
729 981	25	25	25	25	25	25	43	43	43
730 079	32	16	25	31	33	27	55	46	45
730 086	32	16	32	26	35	26	50	48	50
730 093	32	20	25	31	31	27	55	45	45
730 109	32	20	32	26	33	26	50	47	50
730 116	32	25	25	31	26	27	55	45	45
730 123	32	25	32	26	28	26	50	47	50
730 062	32	32	32	28	28	28	53	53	53
732 769	40	25	32	52	35	38	76	53	63
732 776	40	25	40	52	35	52	76	53	76
732 783	40	32	32	53	34	41	76	58	65
732 790	40	32	40	53	34	53	76	58	76
732 752	40	40	40	52	53	52	76	76	75

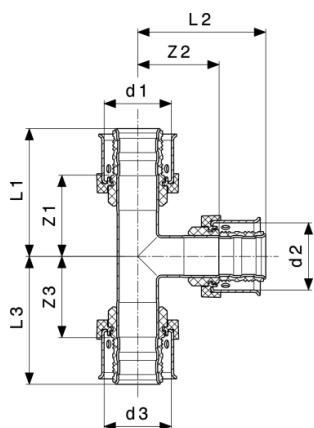

Viega Smartpress T-rör
 - rostfritt stål
Modell 6718

artikel	d1	d2	d3	Z1	Z2	Z3	L1	L2	L3
731 953	50	25	50	61	38	61	90	59	90
732 806	50	32	50	61	37	61	90	62	90
732 813	50	40	50	61	55	61	90	80	90
731 984	50	50	50	61	61	61	90	90	90
732 837	63	25	63	66	42	66	101	60	101
732 844	63	32	63	66	41	66	101	65	101
732 851	63	40	63	66	60	66	101	83	101
732 868	63	50	63	66	64	66	101	93	101
732 820	63	63	63	66	66	66	101	101	101

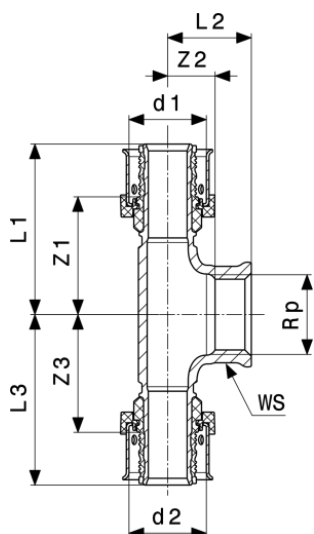

Viega Smartpress T-rör
- rostfritt stål
Modell 6717

artikel	d1	Rp	d2	Z1	Z2	Z3	L1	L2	L3	WS
729 882 ¹	16	½	16	33	7	33	47	22	47	
729 899 ¹	20	½	20	31	7	31	45	22	45	
729 905 ¹	25	¾	25	33	9	33	52	25	52	
729 912 ¹	32	¾	32	36	12	36	61	28	61	
733 308 ²	40	1	40	53	23	53	76	43	76	36
733 315 ²	50	1	50	61	27	61	90	46	90	36
733 322 ²	63	1	63	66	30	66	101	50	101	36

WS = nyckelbredd

1) rödgods

2) rostfritt stål

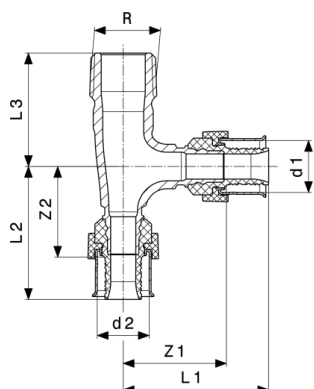

Viega Smartpress T-rör
- rödgods
Modell 6726.4

artikel	R	d1	d2	Z1	Z2	L1	L2	L3	WS
730 444	½	16	16	33	29	47	43	36	18

WS = nyckelbredd

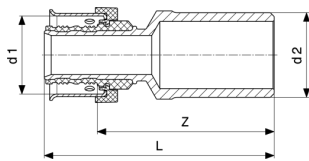

Viega Smartpress insticksstycke
- rödgods
Modell 6713

artikel	VS	PPM	Z	L
729 660	16	15	47	60
729 677	20	22	47	60
729 684	25	22	46	65
729 691	32	28	49	74
733 421	40	35	72	95
733 438	50	42	86	115

VS = för Viega Smartpress

PPM = för presskopplingar av metall presssystem

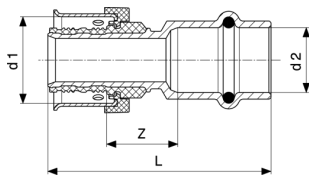

Viega Smartpress övergångsstycke
- rödgods
Modell 6713P

artikel	VS	PPM	Z	L
753 894	16	12	21	52
730 451	16	15	21	56
730 468	20	15	17	53
756 086	20	22	21	59
730 475	25	22	20	61

VS = för Viega Smartpress

PPM = för presskopplingar av metall presssystem

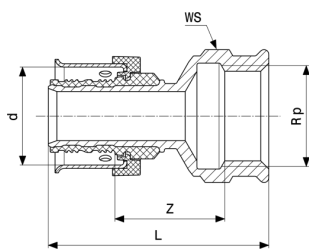

Viega Smartpress övergångsstycke
- rödgods
Modell 6712

artikel	d	Rp	Z	L	WS
729 608	16	½	21	49	26
729 615	16	¾	23	52	31
729 622	20	½	17	46	26
729 639	20	¾	19	49	31
729 646	25	¾	18	53	31
729 653	32	1	20	64	38
733 391	40	1¼	42	87	47
733 407	50	1½	43	94	53
733 414	63	2	42	103	66

WS = nyckelbredd

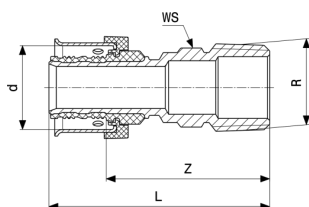

Viega Smartpress övergångsstycke
- rödgods
Modell 6711

artikel	d	R	Z	L	WS
729 523	16	⅜	39	53	14
729 530	16	½	43	57	18
729 547	16	¾	46	60	22
729 554	20	½	40	54	18
729 561	20	¾	42	56	22
729 578	25	¾	42	61	22
729 585	25	1	50	68	27
729 592	32	1	49	74	27
733 278	40	1¼	74	97	43
733 285	50	1½	75	104	50
733 292	63	2	82	117	62

WS = nyckelbredd

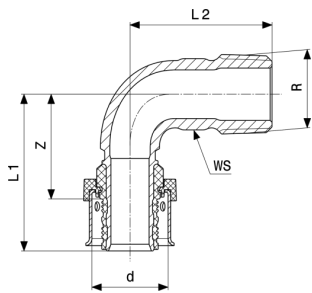

Viega Smartpress övergångsböj 90°
- rödgods
Modell 6714

artikel	d	R	Z	L1	L2	WS
729 707	16	½	33	47	36	18
729 714	20	½	28	42	38	18
729 721	20	¾	31	45	42	23
729 738	25	¾	31	50	44	23
729 745	32	1	38	63	52	29

WS = nyckelbredd

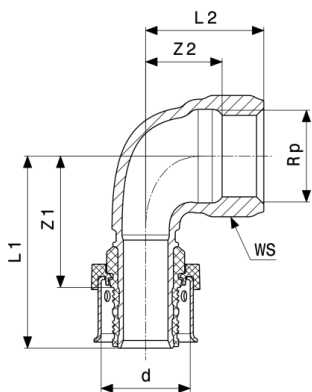

Viega Smartpress övergångsböj 90°
- rödgods
Modell 6714.1

artikel	d	Rp	Z1	Z2	L1	L2	WS
730 352	16	½	34	11	48	26	26
730 345	16	¾	32	12	46	23	22
730 369	20	½	30	12	44	27	26
730 376	20	¾	33	12	47	28	32
730 383	25	¾	34	11	53	27	32

WS = nyckelbredd

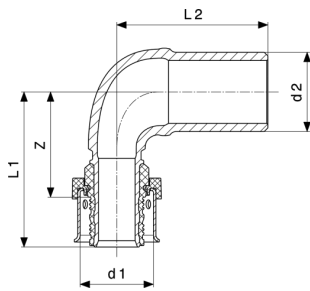

Viega Smartpress plug-in-böj 90°
- rödgods
Modell 6793

artikel	VS	PPM	Z	L1	L2
730 321	16	15	28	41	38
730 338	20	22	29	43	42

VS = för Viega Smartpress
PPM = för presskopplingar av metall presssystem

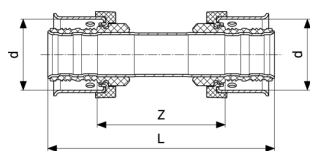

Viega Smartpress koppling
- rostfritt stål
Modell 6715

artikel	d	Z	L
729 752	16	40	67
729 769	20	38	65
729 783	25	39	77
729 813	32	43	92
733 339	40	73	120
733 353	50	75	133
733 377	63	80	150

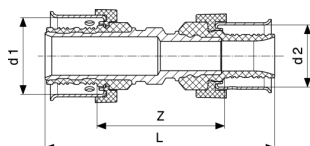

Viega Smartpress förminskningskoppling
- rödgods
Modell 6715.2

artikel	d1	d2	Z	L
729 776	20	16	35	62
729 790	25	16	35	67
729 806	25	20	32	64
729 820	32	20	35	73

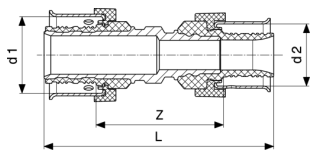

Viega Smartpress förminskningskoppling
- rödgods
Modell 6715.2

artikel	d1	d2	Z	L
729 837	32	25	34	77
733 346	40	32	54	102
733 360	50	40	73	126
733 384	63	50	77	141

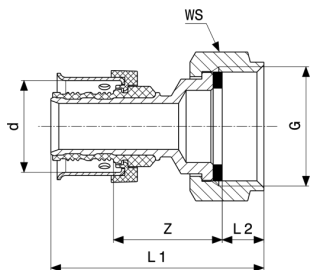

Viega Smartpress anslutningskruvförband
- rödgods
Modell 6763

artikel	d	G	Z	L1	L2	WS
730 208	16	½	27	43	5	23
730 215	16	¾	28	51	9	30
730 222	20	½	23	42	5	23
730 239	20	¾	24	47	9	30
730 246	25	¾	26	53	9	30
730 253	32	1¼	28	65	12	50
733 445	40	1¼	46	81	12	50
733 452	40	1½	49	82	9	52
733 469	50	1¾	50	89	10	59
733 476	50	2¾	54	94	11	75
733 483	63	2¾	54	98	11	75

WS = nyckelbredd

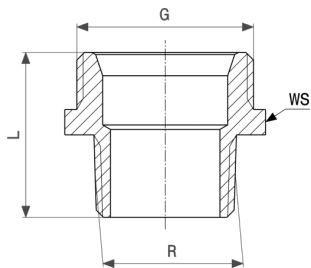

Övergångsnippel
- rödgods eller siliciumbrons
Modell 3246

artikel	R	G	L	WS
449 339	½	½	30	22
441 524	½	¾	21	27
449 346	¾	¾	33	28

WS = nyckelbredd

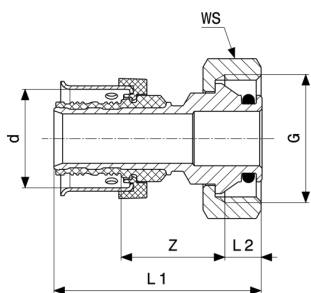

Viega Smartpress anslutningskruvförband
- rödgods
Modell 6735

artikel	d	G	Z	L1	L2	WS
730 598	16	¾	25	46	8	30
730 604	20	¾	22	43	8	30
730 611	25	¾	21	47	8	30

WS = nyckelbredd

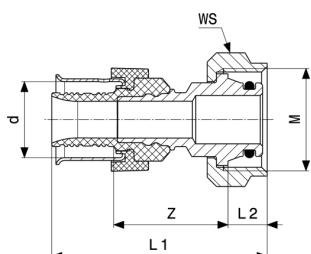

Viega Smartpress anslutningskruvförband
- rödgods
Modell 6783

artikel	d	M	Z	L1	L2	WS
730 307	16	22	25	48	9	26
730 314	16	24	26	49	10	27

WS = nyckelbredd

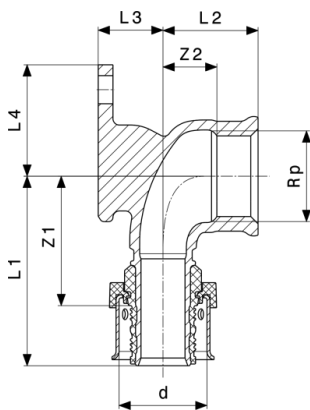

Viega Smartpress veggfäste
- rödgods
Modell 6725.5

artikel	d	Rp	Z1	Z2	L1	L2	L3	L4
729 479	16	½	33	7	47	22	13	27
729 486	20	½	30	7	44	22	15	27
729 493	20	¾	34	9	48	25	18	31

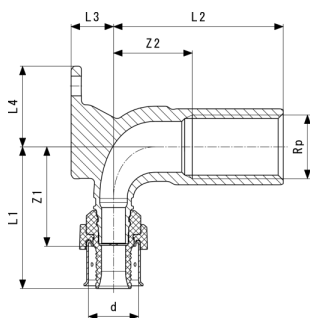

Viega Smartpress veggfäste
- rödgods
Modell 6725

artikel	Z1	Z2	L1	L2	L3	L4
783 921	33	26	47	56	14	27

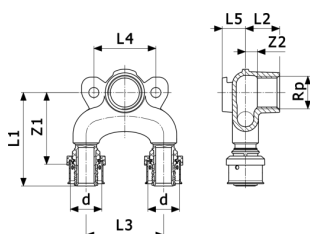

Viega Smartpress dubbelt veggfäste
- rödgods
Modell 6725.7

artikel	d	Rp	Z1	Z2	L1	L2	L3	L4	L5
730 413	16	½	51	7	65	22	50	40	13
730 420	20	½	46	7	60	22	50	40	15
730 437	25	½	48	7	66	22	50	40	15

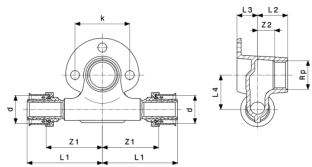

Viega Smartpress väggfästen T-rör
- rödgods
Modell 6724.3

artikel	d	Rp	Z1	Z2	L1	L2	L3	L4	k
729 509	16	½	46	7	60	22	13	25	40
729 516	20	½	41	7	55	22	15	25	40

k = bultdiameter

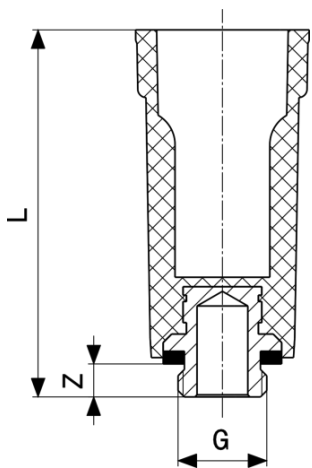

Tryckplugg
- plast
Modell 1516.113

artikel	G	Z	L
116 644	⅜	7	85
100 766	½	11	92
107 666	¾	9	87

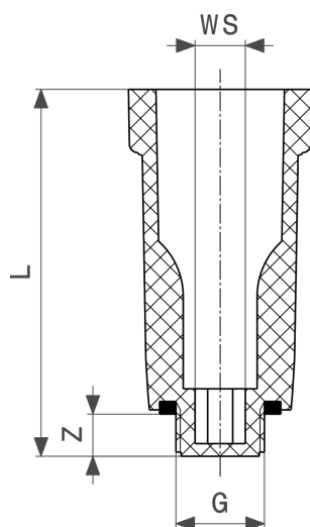

Tryckplugg
- plast
Modell 1516

artikel	G	Z	L	WS
107 796	3/8	10	87	8
100 124	1/2	10	87	10
102 746	3/4	13	90	14

WS = nyckelbredd

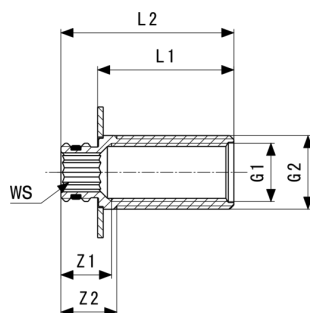

Väggenomföring
Modell 2032.1

artikel	G1	G2	L	Z1	Z2	L1	L2	WS
764 067	1/2	3/4	35	18	20	37	50	12
764 074	1/2	3/4	47	17	20	49	62	12

WS = nyckelbredd

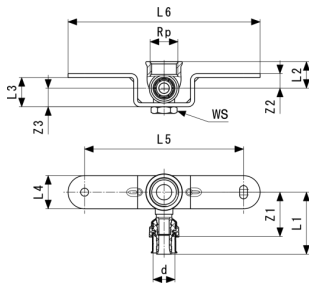

Viega Smartpress monteringsenhet
- galvaniserat stål
Modell 6723

artikel	d	Rp	Z1	Z2	Z3	L1	L2	L3	L4	L5
750 152	16	½	33	11	14	47	20	22	25	120

artikel	d	Rp	L6	WS
750 152	16	½	145	17

WS = nyckelbredd

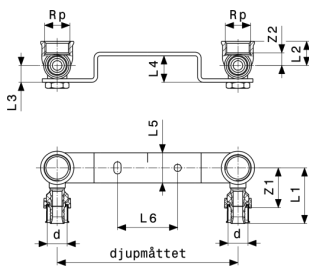

Viega Smartpress monteringsenhet
- galvaniserat stål
Modell 6724

artikel	d	Rp	stickmått	Z1	Z2	L1	L2	L3	L4	L5
730 130	16	¾	120	33	5	47	16	14	18	25
730 147	16	½	150	33	5	47	20	14	22	25

artikel	d	Rp	stickmått	L6
730 130	16	¾	120	40
730 147	16	½	150	50

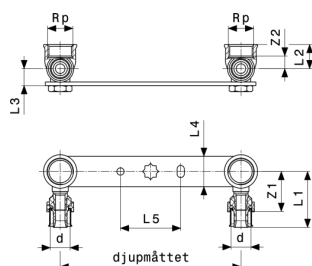

Viega Smartpress monteringsenhet
- galvaniserat stål
Modell 6724.1

artikel	d	Rp	stickmått	Z1	Z2	L1	L2	L3	L4	L5
730 390	16	½	150	33	8	47	20	14	25	50

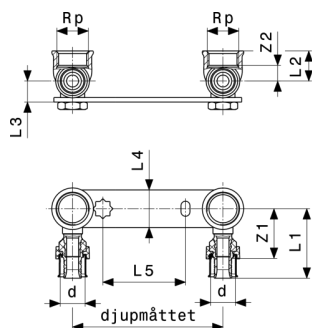

Viega Smartpress monteringsenhet
- galvaniserat stål
Modell 6724.2

artikel	d	Rp	stickmått	Z1	Z2	L1	L2	L3	L4	L5
730 406	16	½	80/100	33	5	47	20	14	25	55

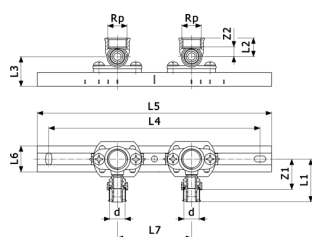

Viega Smartpress monteringsenhet
- galvaniserat stål
Modell 6741

artikel	d	Rp	Z1	Z2	L1	L2	L3	L4	L5	L6
730 628	16	½	33	7	47	22	32	228	253	28

artikel	d	Rp	L7
730 628	16	½	80

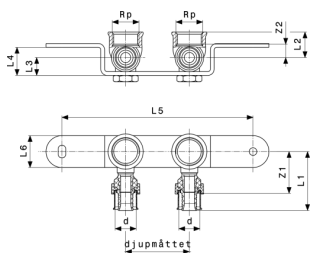

Viega Smartpress monteringsenhet
- galvaniserat stål
Modell 6723.1

artikel	d	Rp	stickmått	Z1	Z2	L1	L2	L3	L4	L5
730 499	16	½	35/45/50	33	5	47	20	10	22	150

artikel	d	Rp	stickmått	L6
730 499	16	½	35/45/50	25

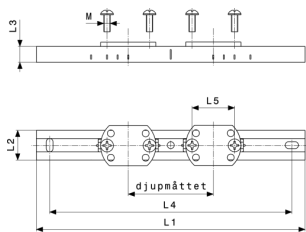

Fäste
- galvaniserat stål
Modell 2141.3

artikel	stickmått	L1	L2	L3	L4	L5	M
581 701	80-150	253	28	15	228	40	6

M = gängtyp

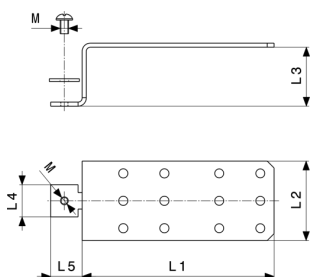

Fäste
- galvaniserat stål
Modell 2141.4

artikel	L1	L2	L3	L4	L5	M
586 706	140	58	43	24	23	6

M = gängtyp

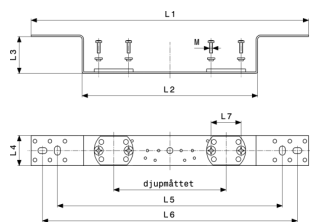

Fäste
- galvaniserat stål
Modell 2021.7

artikel	stickmått	L1	L2	L3	L4	L5	L6	L7	M
651 350	70/100/150	370	234	48	40	300	340	40	4

M = gängtyp

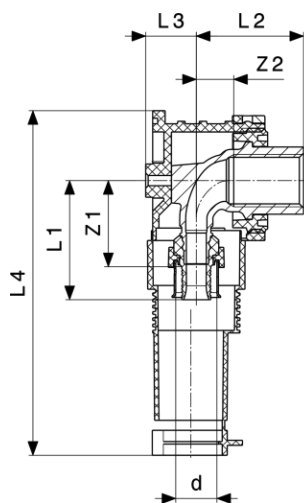

Viega Smartpress kopplingsdosa 90°
- rödgods
Modell 6720.01

artikel	d	Rp	Z1	Z2	L1	L2	L3	L4
730 581	16	½	34	15	48	43	20	138

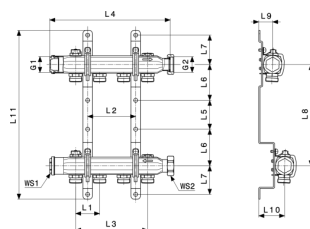

Fördelare
- rostfritt stål
Modell 1078

artikel	n	L1	L2	L3	L4	L5	L6	L7	L8	L9
586 225	2	50			142	60	75	60	210	28
586 232	3	50	50	100	192	60	75	60	210	28
586 249	4	50	100	150	242	60	75	60	210	28
587 550	5	50	150	200	292	60	75	60	210	28

WS = nyckelbredd

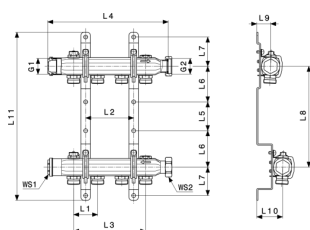

Fördelare
- rostfritt stål
Modell 1078

artikel	n	L1	L2	L3	L4	L5	L6	L7	L8	L9
587 567	6	50	200	250	342	60	75	60	210	28
587 574	7	50	250	300	392	60	75	60	210	28
587 581	8	50	300	350	442	60	75	60	210	28
587 598	9	50	350	400	492	60	75	60	210	28
587 604	10	50	400	450	542	60	75	60	210	28
587 611	11	50	450	500	592	60	75	60	210	28
587 628	12	50	500	550	642	60	75	60	210	28

artikel	n	L10	L11	WS1	WS2	G1	G2
586 225	2	53	350	25	37	¾	1
586 232	3	53	350	25	37	¾	1
586 249	4	53	350	25	37	¾	1
587 550	5	53	350	27	37	¾	1
587 567	6	53	350	25	37	¾	1
587 574	7	53	350	25	37	¾	1
587 581	8	55		25	37	¾	1
587 598	9	55		25	37	¾	1
587 604	10	53	350	25	37	¾	1
587 611	11	53	350	25	37	¾	1
587 628	12	53	350	25	37	¾	1

WS = nyckelbredd

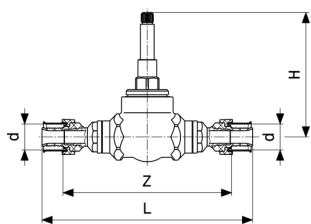

Viega Smartpress dold frilödesventil
- mässing
Modell 6770

artikel	d	Z	L	H
730 260	16	109	136	79
730 277	20	101	129	79

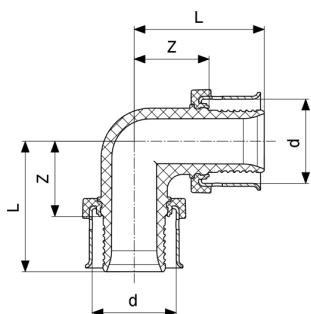

Viega Smartpress/Pexfit Pro böj 90°
- PPSU
Modell 4716

artikel	d	Z	L
608 613	16	16	30
608 637	20	18	31
608 644	25	21	38

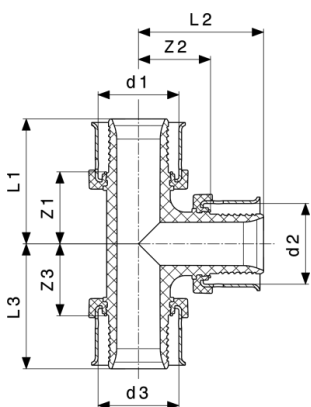

Viega Smartpress/Pexfit Pro T-rör
- PPSU
Modell 4718

artikel	d1	d2	d3	Z1	Z2	Z3	L1	L2	L3
608 781	16	16	16	16	16	16	30	30	30
608 842	16	20	16	18	16	18	31	30	31

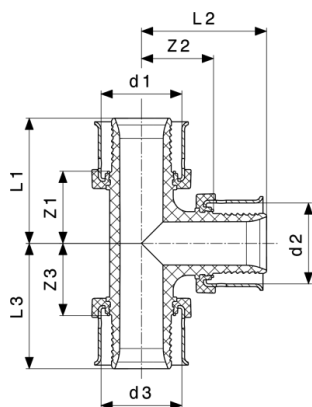

Viega Smartpress/Pexfit Pro T-rör
- PPSU
Modell 4718

artikel	d1	d2	d3	Z1	Z2	Z3	L1	L2	L3
608 880	20	16	16	16	18	16	29	31	29
608 897	20	16	20	16	18	16	29	31	29
608 903	20	20	16	18	18	18	32	32	32
608 804	20	20	20	18	18	18	32	32	32
608 910	25	16	16	17	21	17	34	34	30
608 927	25	16	20	17	21	17	34	34	30
608 934	25	16	25	17	21	17	34	34	34
608 965	25	20	20	18	21	18	36	34	32
608 972	25	20	25	18	21	18	36	34	36
608 941	25	25	16	21	21	21	38	38	34
608 958	25	25	20	21	21	21	38	38	34
608 811	25	25	25	21	21	21	38	38	38

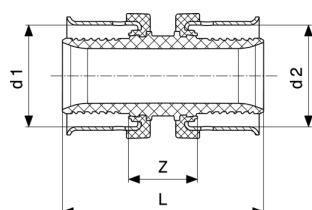

Viega Smartpress/Pexfit Pro koppling
- PPSU
Modell 4715

artikel	d1	d2	Z	L
608 668	16	16	14	41
608 729	20	16	14	41
608 682	20	20	14	41
608 743	25	16	14	45
608 736	25	20	14	45
608 699	25	25	14	49

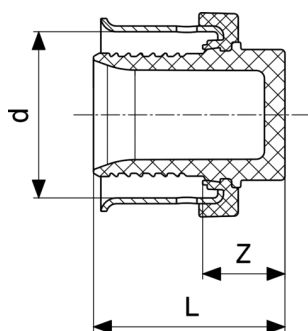

Viega Smartpress/Pexfit Pro lock
- PPSU
Modell 4756

artikel	d	Z	L
608 569	16	9	23
608 583	20	9	23
608 590	25	10	27

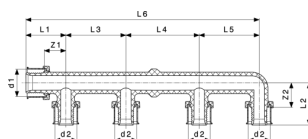

Viega Smartpress/Pexfit Pro fördelare
- PPSU
Modell 4733

artikel	d1	d2	Z1	Z2	L1	L2	L3	L4	L5	L6
610 111*	20	16	16	18	30	32	45	55		130
610 135*	20	16	16	18	30	32	45	55	45	175
610 098	20	16	17	18	30	32	45			75

* = Levereras så länge lagret räcker

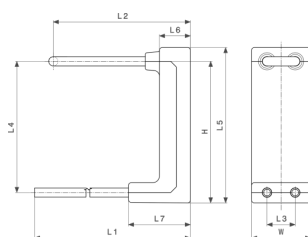

Viega Smartpress radiatoranslutningsblock
- flerskiktsrör
Modell 6797.6

artikel	H	L1	L2	L3	L4	L5	L6	L7	B
730 512*	250	423	244	50	233	275	55	110	105

* = Levereras så länge lagret räcker

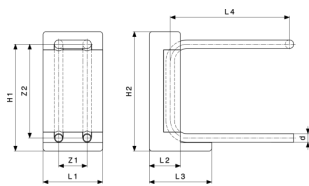

**Radiatoranslutningsblock
Modell 1097.6**

artikel	d	Z1	Z2	L1	L2	L3	L4	H1	H2
364 045	15	50	165	105	55	110	210	188	210
379 698	15	50	235	105	55	110	210	258	280

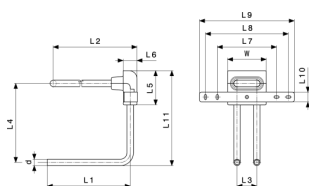

**Viega Smartpress radiatoranslutningsblock
- flerskiktsrör
Modell 6797.7**

artikel	d	L1	L2	L3	L4	L5	L6	L7	L8	L9
730 529	16	210	392	50	200	87	35	150	210	240

artikel	d	L10	L11	B
730 529	16	25	232	98

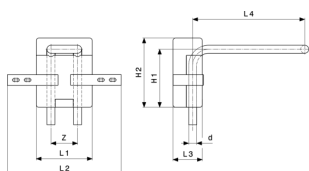

**Radiatoranslutningsblock
Modell 1097.9**

artikel	d	H	Z	L1	L2	L3	L4	H1	H2
586 379	15	150	50	105	214	55	210	109	130

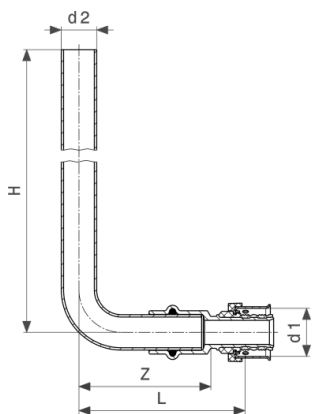

Viega Smartpress radiatoranslutningsset
 - rostfritt stål
Modell 6777

artikel	VS	PPM	H	Z	L
730 291	16	15	350	73	86

VS = för Viega Smartpress
 PPM = för presskopplingar av metall presssystem

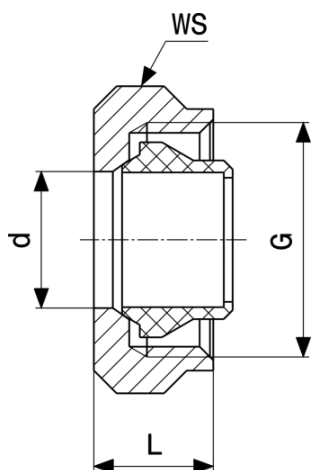

Anslutningsskruvförband
 - förnicklad mässing
Modell 94385.2

artikel	d	G	L	WS
636 050	15	¾	14	30

WS = nyckelbredd

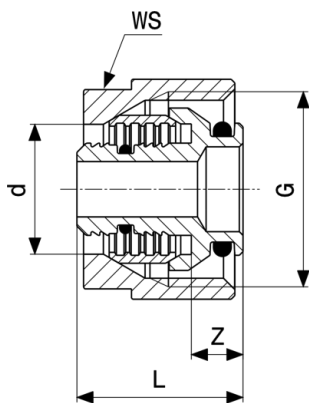

Anslutningsskruvförband
- förnicklad mässing
Modell 1037

artikel	d	G	Z	L	WS
614 522	16	¾	6	25	27

WS = nyckelbredd

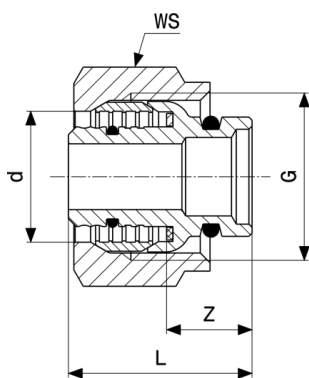

Klämringsskruvförband
- mässing
Modell 1019

artikel	d	s	Z	L	WS	G
356 682	16	2	13	29	30	¾

WS = nyckelbredd

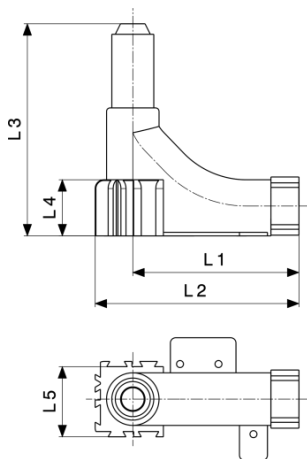

**Rörledningsbøj 90°
Modell 1072.3**

artikel	L1	L2	L3	L4	L5
309 855	95	117	121	32	37

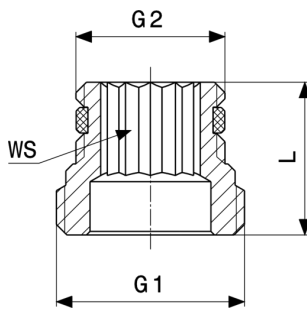

**Adapterset
- mässing
Modell 1096.8**

artikel	G1	G2	L	WS
357 122	½	¾	22	12

WS = nyckelbredd

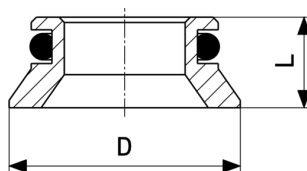

**Adapterset
Modell 1096.9**

artikel	D	L
308 872	22	9

D = utvändig diameter

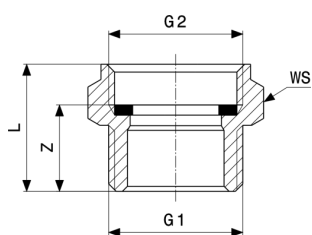

Adapterset
- mässing
Modell 1022.7

artikel	G1	G2	Z	L	WS
279 547	¾	¾	14	22	30

WS = nyckelbredd

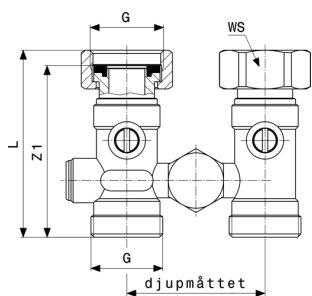

Radiatoranslutningstycke
- mattförnicklad mässing
Modell 1096.0

artikel	G	stickmått	Z1	L	WS
359 096	¾	50	62	68	30

WS = nyckelbredd

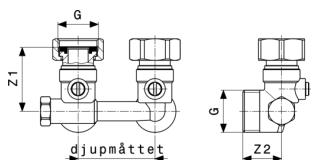

Radiatoranslutningstycke
- mattförnicklad mässing
Modell 1097.0

artikel	G	stickmått	Z1	Z2	L	WS
359 126	¾	50	43	25	47	30

WS = nyckelbredd

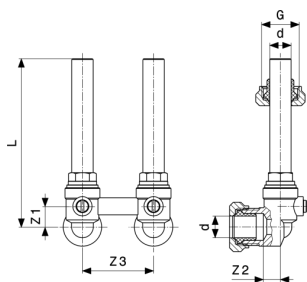

Radiatoranslutningsset
- mattförlackad mässing
Modell 1097.7

artikel	d	G	Z1	Z2	Z3	L
364 052	15	3/4	15	11	50	118

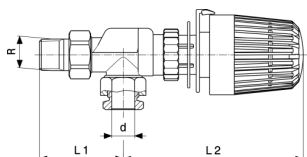

Radiatoraxialventil
- förlackad mässing
Modell 1075.96

artikel	d	R	L1	L2
360 405	15	1/2	56	120

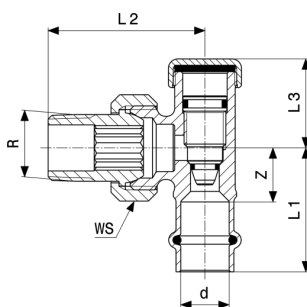

Sanpress skruvförband för returledning
- rödgods
Modell 2272.1

artikel	d	R	Z	L1	L2	L3	WS
326 357	15	1/2	17	39	50	28	29

WS = nyckelbredd

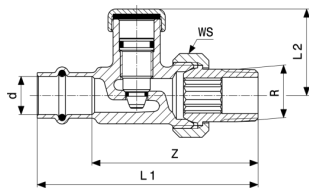

Sanpress skruvförband för returledning
- rödgods
Modell 2272.2

artikel	d	R	Z	L1	L2	WS
326 364	15	½	67	89	35	29

WS = nyckelbredd

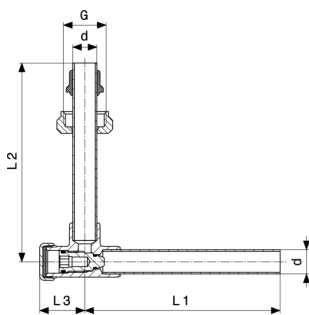

Radiatoranslutningsset
- förnicklad mässing
Modell 2272.5

artikel	d	G	L1	L2	L3
360 399	15	¾	121	123	28

Avtryck

Viega GmbH & Co. KG

Viega Platz 1

57439 Attendorn

Germany

Phone: +49/2722/61-0

Fax: +49/2722/61-1566

The Viega GmbH & Co. KG is represented by the general partners: Viega Management B.V. (Managing directors: Michael Klenz, Sebastian Leigemann) and Viega Management GmbH (Managing directors: Michael Klenz, Sebastian Leigemann)

Submittal Package innehåller icke-bindande information som görs tillgänglig för dig. Allt innehåll i detta Submittal Package sammanställs med största noggrannhet. Vi kan dock inte garantera att informationen är aktuell, korrekt eller fullständig. Submittal Package utgör inte en del av avtalet vid en beställning.